

- ÍNDICE -

A.- Descripción Técnica

B.- Relación perfiles

C.- Accesorios y juntas

D.- Perfiles a escala

F.- Hojas de corte

G.- Secciones tipo

H.- Fabricación

Características técnicas

RT64 C16 - A1

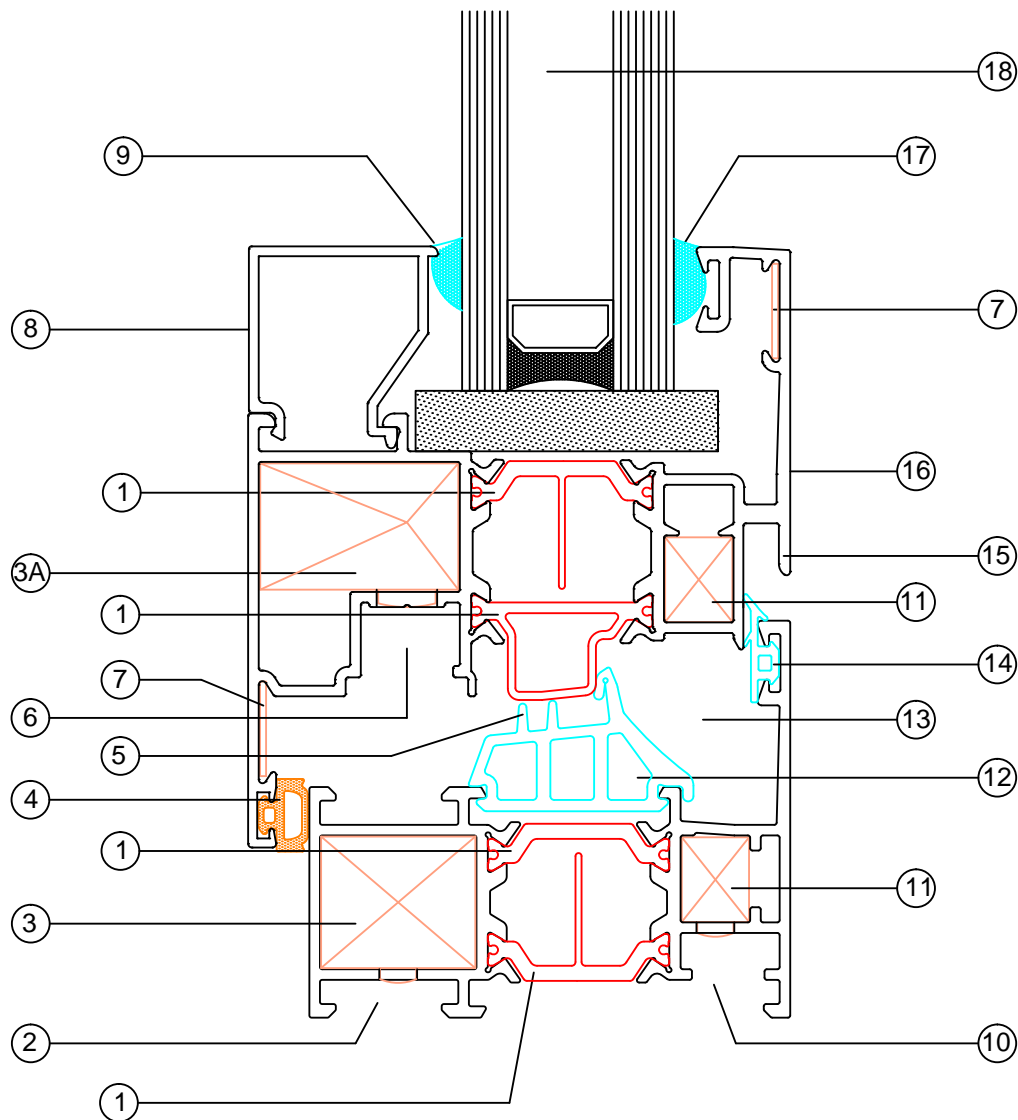

- ① Rotura térmica con poliamidas de 24 mm
- ② Posibilidad recercado interior
- ③ Escuadra interior extrusión
- ④ Junta interior espumosa
- ⑤ Pestañas para aislamiento térmico
- ⑥ Accesorios cámara canal 16
- ⑦ Escuadra alineamiento en inox.
- ⑧ Junquillos acristalar 22 mm rectos o curvos
- ⑨ Sellado con silicona o junta EPDM

- ⑩ Posibilidad de vierteaguas exterior o condensador
- ⑪ Escuadra exterior con tetón de resorte ó extrusión
- ⑫ Junta central en EPDM
- ⑬ Amplia cámara evacuación agua exterior
- ⑭ Posibilidad de junta exterior en EPDM
- ⑮ Amplio vierteaguas exterior en hoja
- ⑯ Hoja coplanar
- ⑰ Sellado con silicona o junta EPDM
- ⑱ Amplia posibilidad de acristalamiento



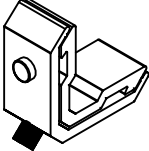
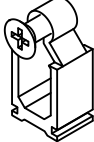
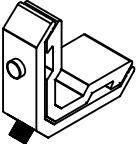
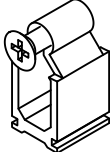
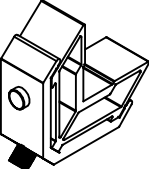
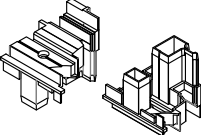
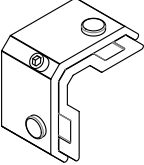
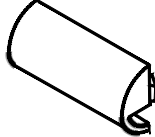
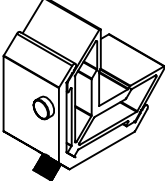
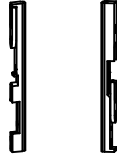
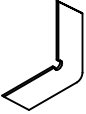
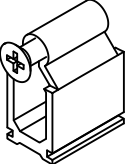

Relación de accesorios

RT64 C16 - C1

Ref.	Esquema	Descripción	Ref.	Esquema	Descripción
0701070045		Escuadra 17 x 20 extrusión	0701070047		Tope travesaño 17 mm
0701070046		Escuadra 11 x 9 extrusión	0701070052		Tope travesaño 23 mm
0701070048		Escuadra 36 x 20 extrusión	0901330005		Juego tapa inversora
0701070049		Escuadra 17 x 26 extrusión	1103170002		Tapa salida agua
0701070050		Escuadra 40 x 26 extrusión	Superior Inferior		Pasadores P.E. hoja pasiva
0708090001		Escuadra alineamiento			Manilla P.E. doble
0701070035		Tope travesaño 36 mm	Herrajes: Ver pag. H5, H6 y H7		

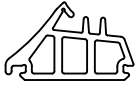
Relación de juntas

RT64 C16 - C2

Ref.	Esquema	Descripción	Ref.	Esquema	Descripción
0803150010		Junta estanqueidad central (EPDM)			
0803040015		Junta exterior (EPDM)			
0803050002		Junta interior (espumosa)			
		Junta suplemento térmico bajo vidrio (celular)			

Perfiles escala 1:1

RT64 C16 - D1

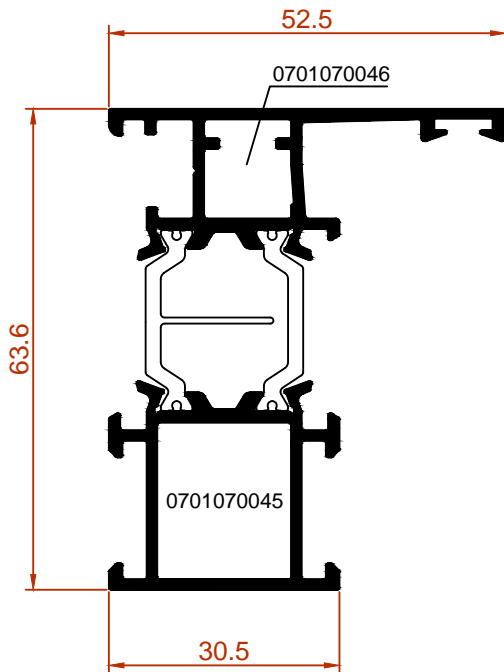

64-01 $I_{xx} = 20,48 \text{ cm}^4$
 $I_{yy} = 5,81 \text{ cm}^4$

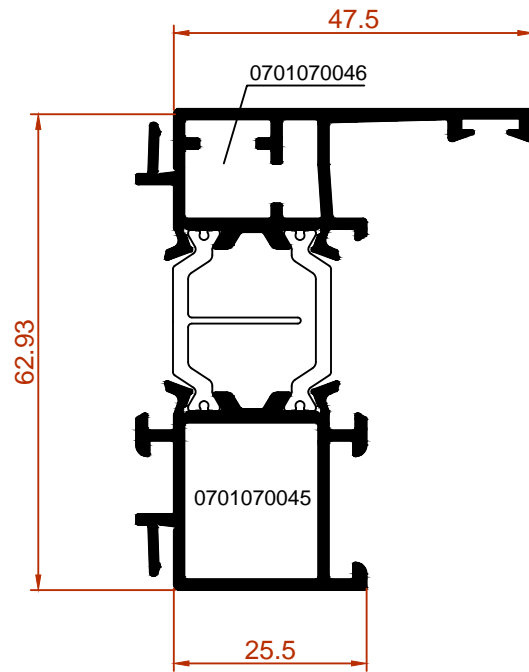

64-86 $I_{xx} = 20,67 \text{ cm}^4$
 $I_{yy} = 6,16 \text{ cm}^4$

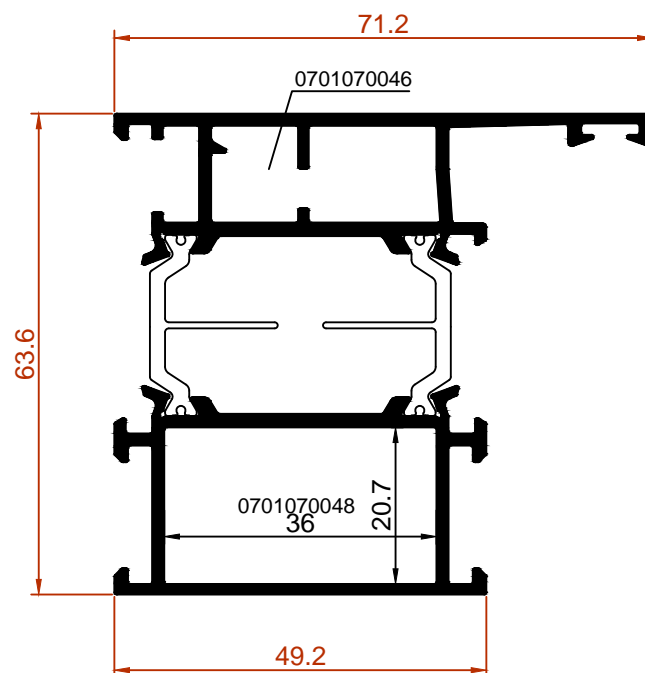

64-14 $I_{xx} = 28,25 \text{ cm}^4$
 $I_{yy} = 17,47 \text{ cm}^4$

Perfiles escala 1:1

RT64 C16 - D2

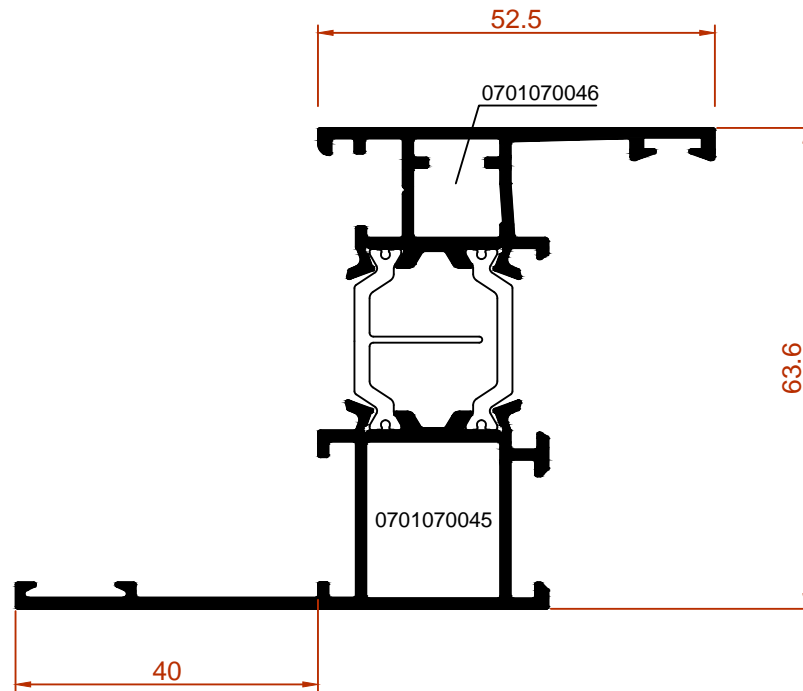

64-01L $I_{xx} = 27,37 \text{ cm}^4$
 $I_{yy} = 15,93 \text{ cm}^4$

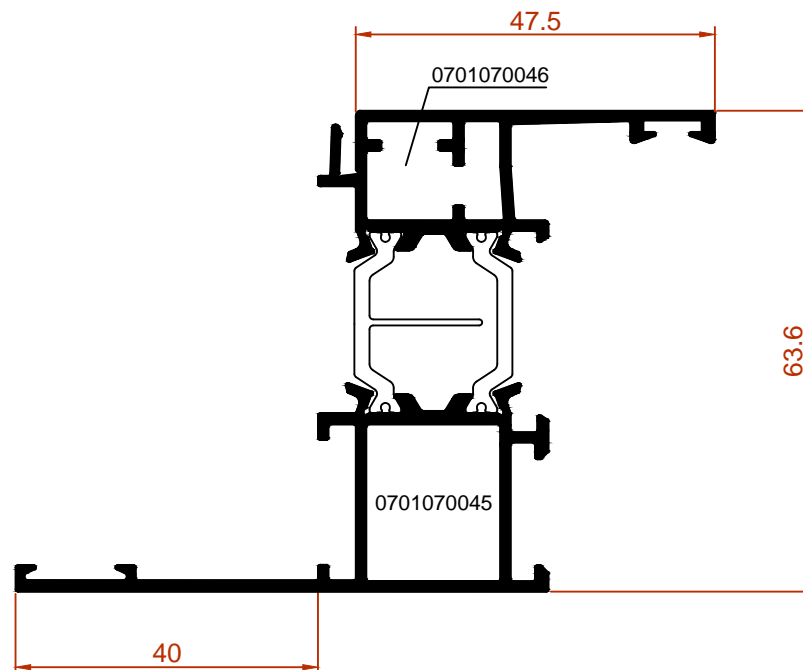

64-82 $I_{xx} = 27,73 \text{ cm}^4$
 $I_{yy} = 16,04 \text{ cm}^4$

Perfiles escala 1:1

RT64 C16 - D3

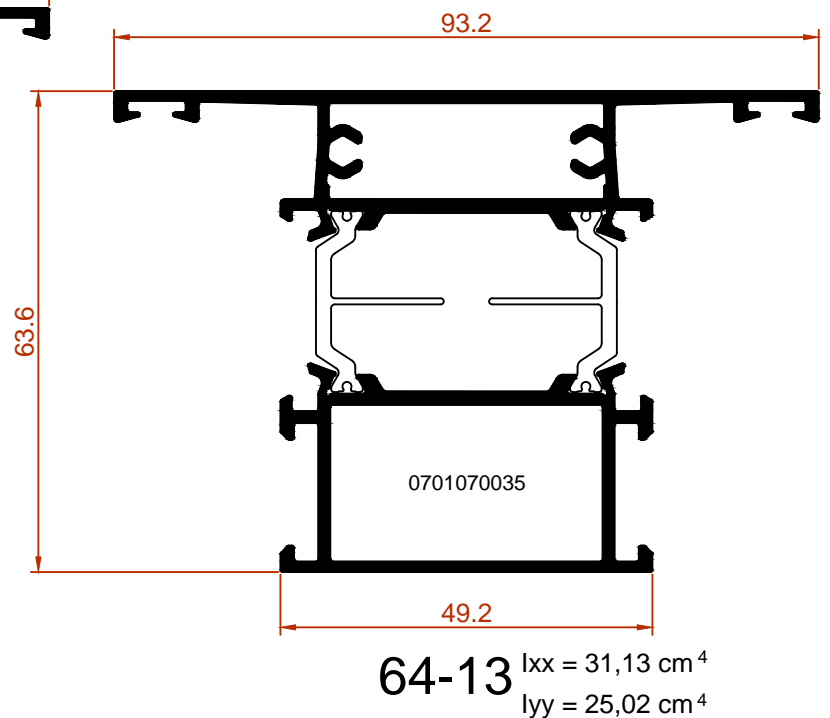
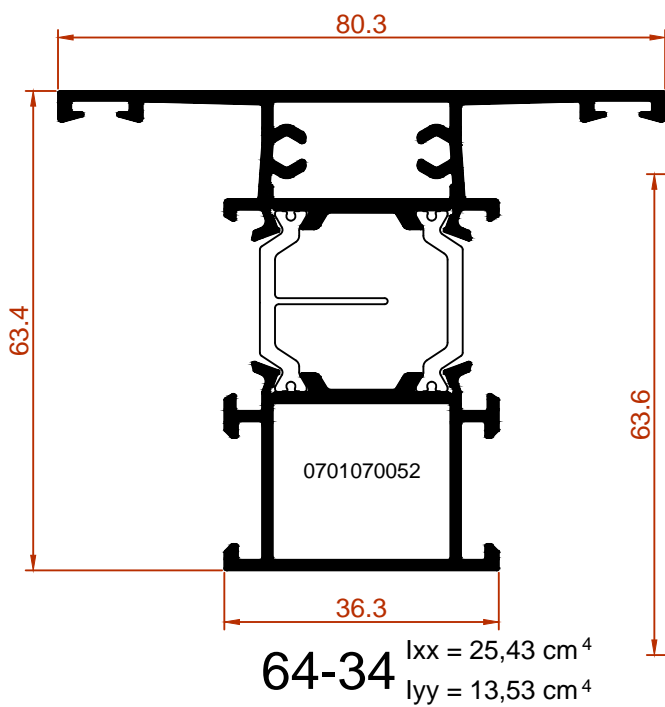
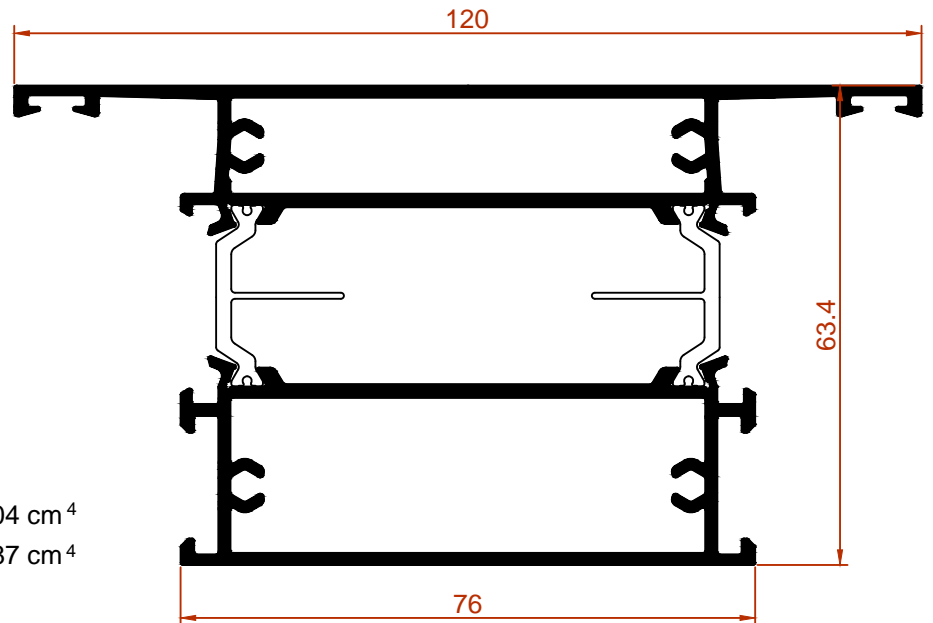
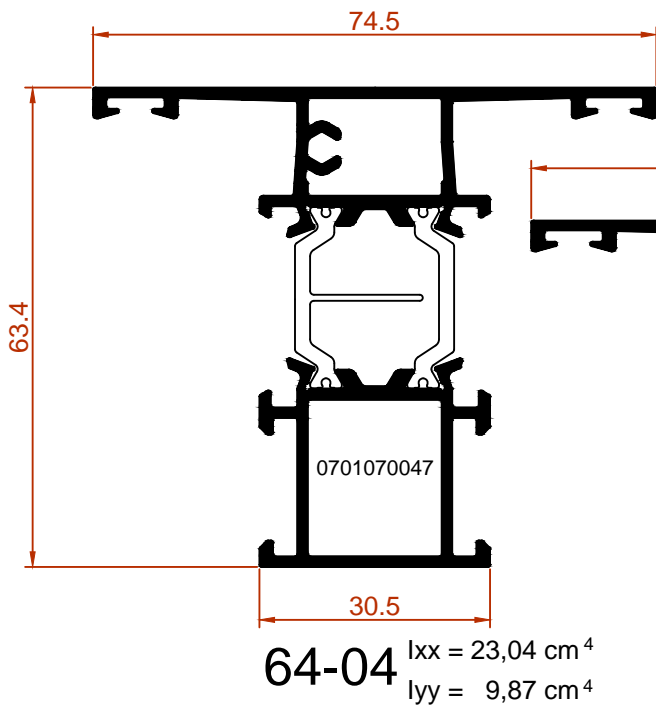

Perfiles escala 1:1

RT64 C16 - D4

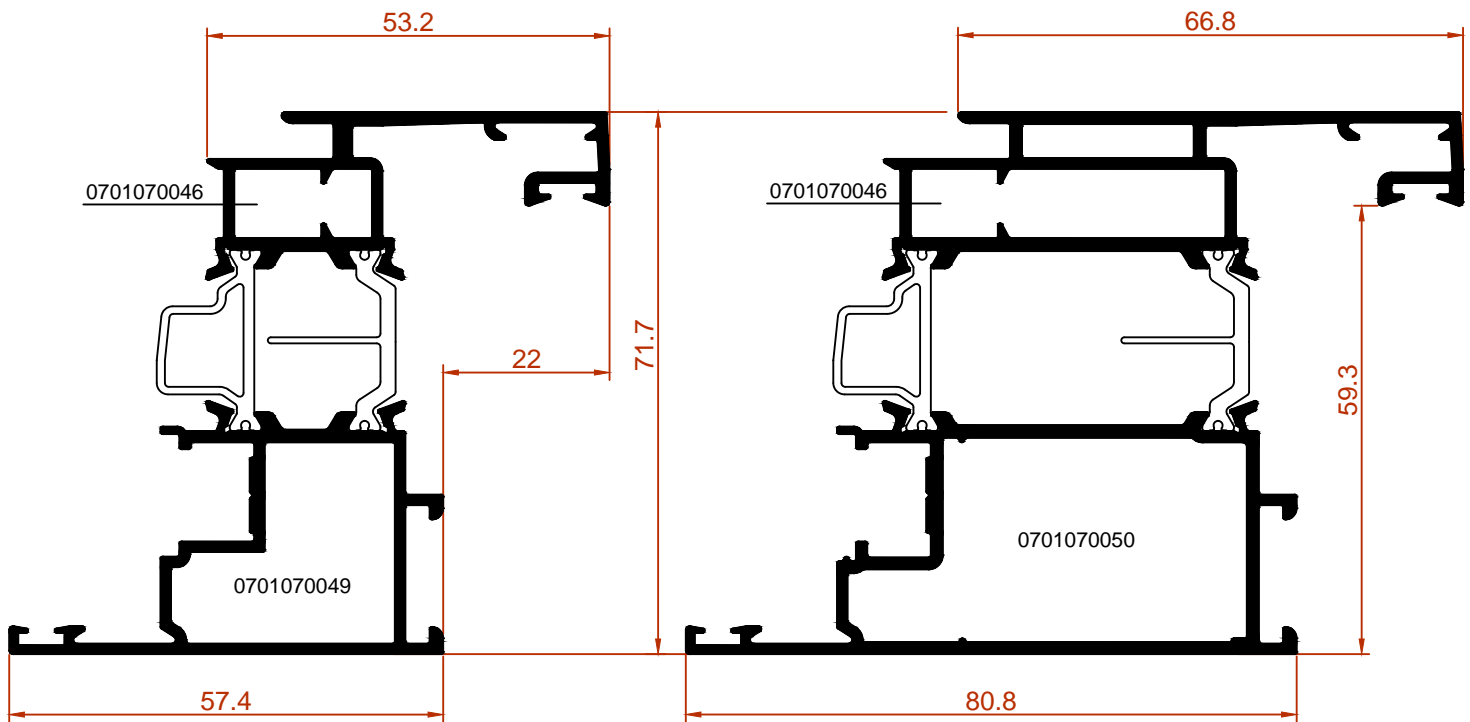

64-102 $I_{xx} = 35,15 \text{ cm}^4$
 $I_{yy} = 15,26 \text{ cm}^4$

64-115 $I_{xx} = 50,25 \text{ cm}^4$
 $I_{yy} = 40,53 \text{ cm}^4$

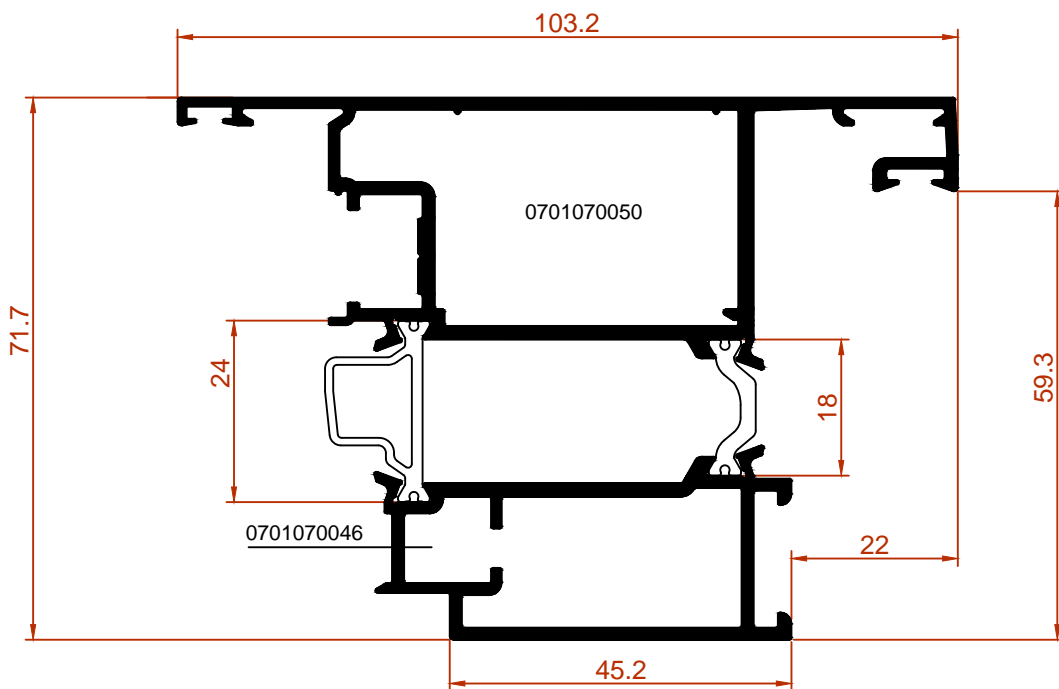

64-111 $I_{xx} = 46,34 \text{ cm}^4$
 $I_{yy} = 43,06 \text{ cm}^4$

Perfiles escala 1:1

RT64 C16 - D5

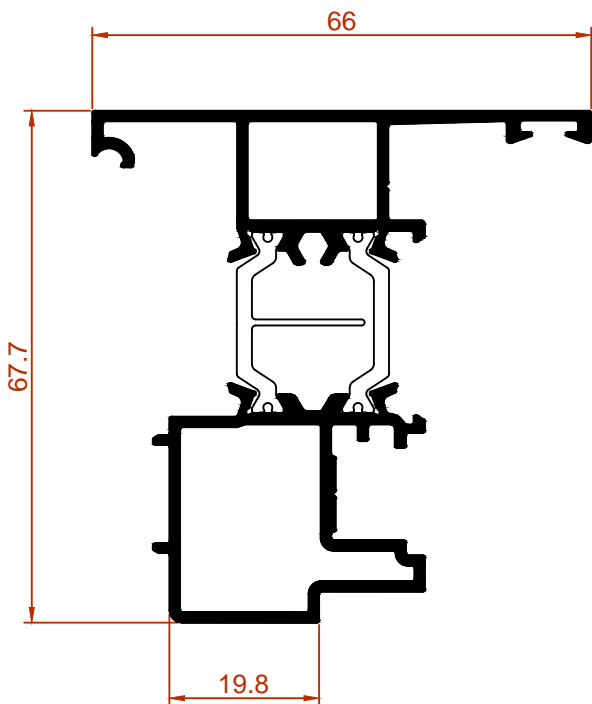

64-103 $I_{xx} = 25,75 \text{ cm}^4$
 $I_{yy} = 9,13 \text{ cm}^4$

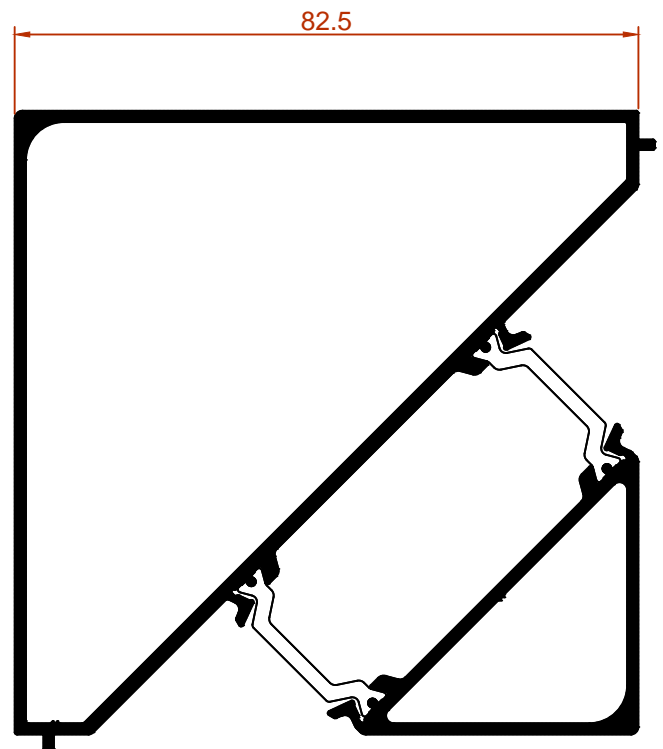

RTA72-08 $I_{xx} = 60,20 \text{ cm}^4$
 $I_{yy} = 60,20 \text{ cm}^4$

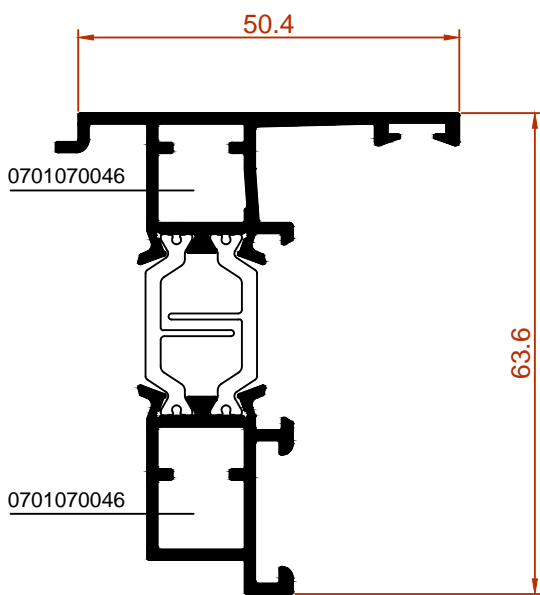

64-26 $I_{xx} = 15,96 \text{ cm}^4$
 $I_{yy} = 3,81 \text{ cm}^4$

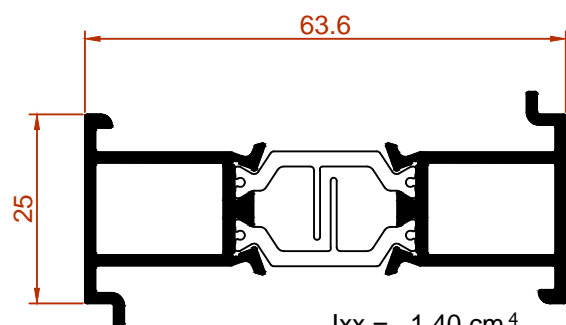

64-07 $I_{xx} = 1,40 \text{ cm}^4$
 $I_{yy} = 14,73 \text{ cm}^4$

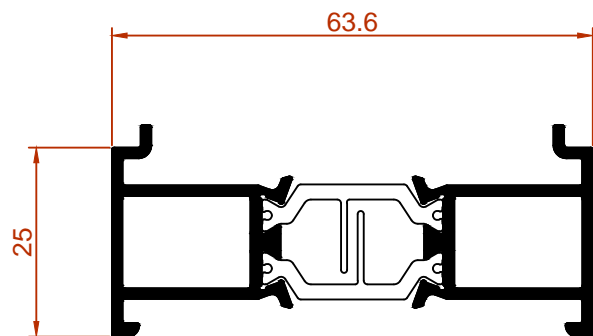

64-28 $I_{xx} = 1,39 \text{ cm}^4$
 $I_{yy} = 14,73 \text{ cm}^4$

Perfiles escala 1:1

RT64 C16 - D6

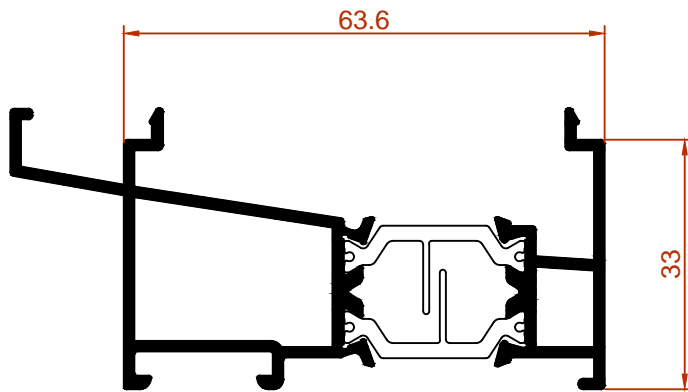

64-24

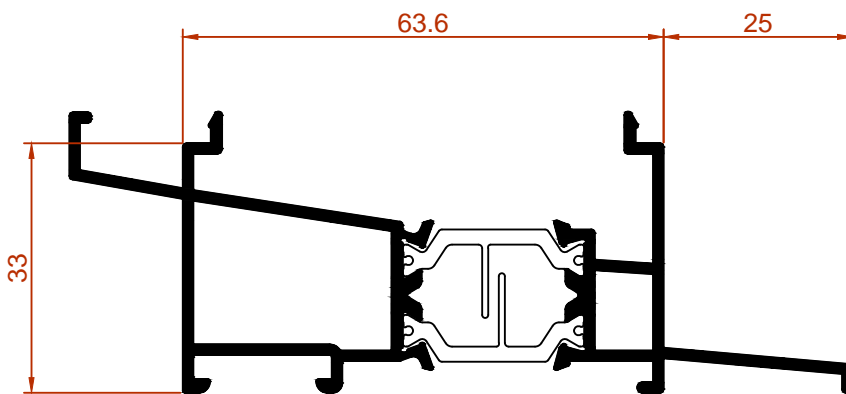

64-05

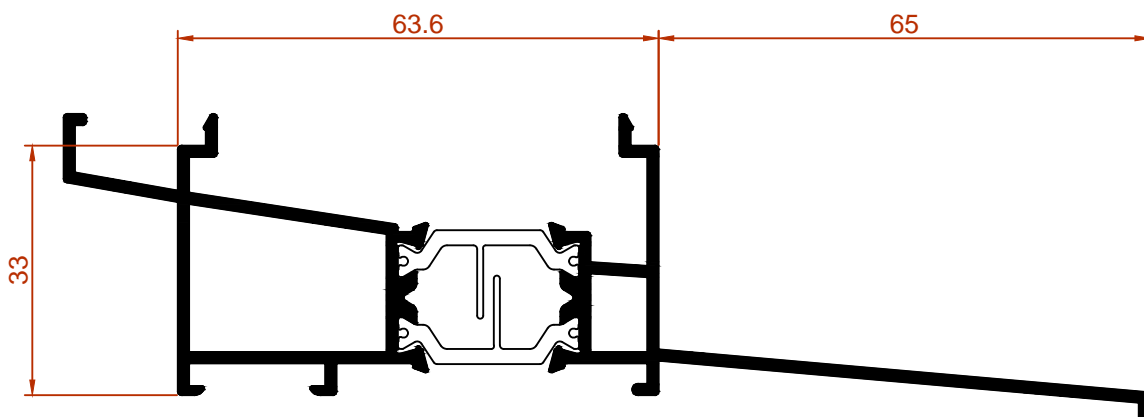

64-06

Perfiles escala 1:1

RT64 C16 - D7

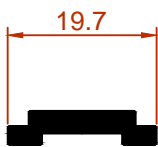
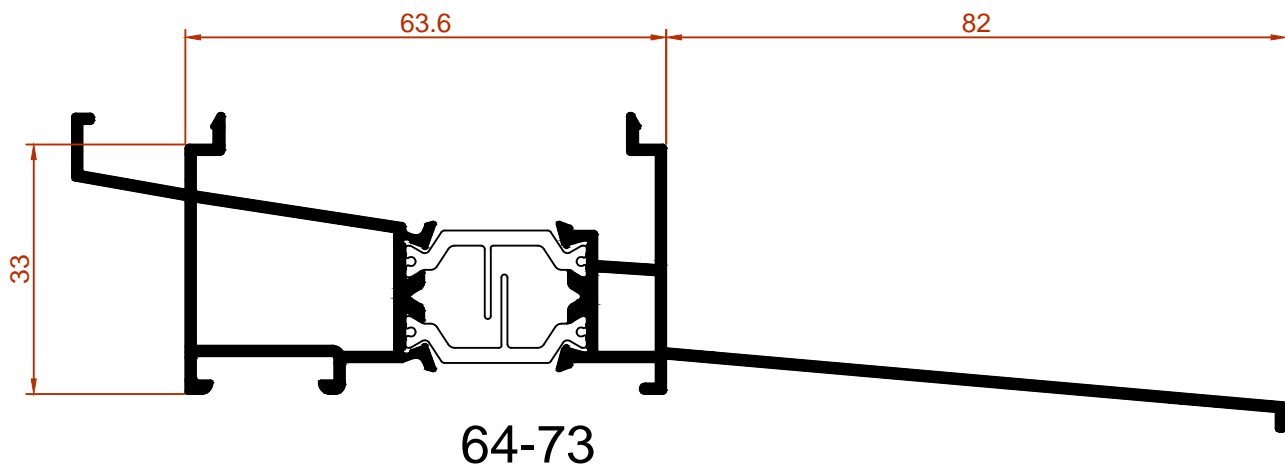

BX-51

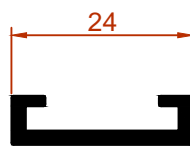

GFT-39

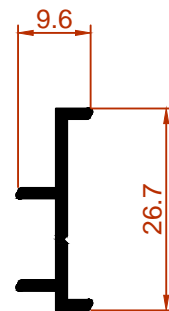

GALI-1022

Perfiles escala 1:1

RT64 C16 - D8

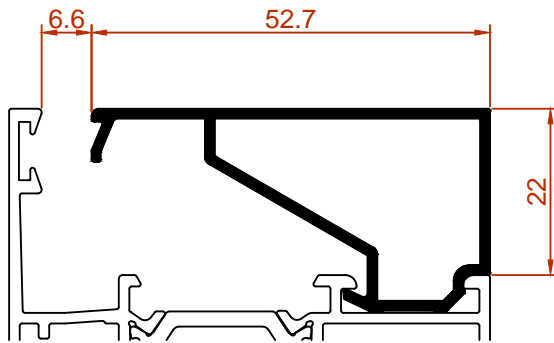

S90-66E

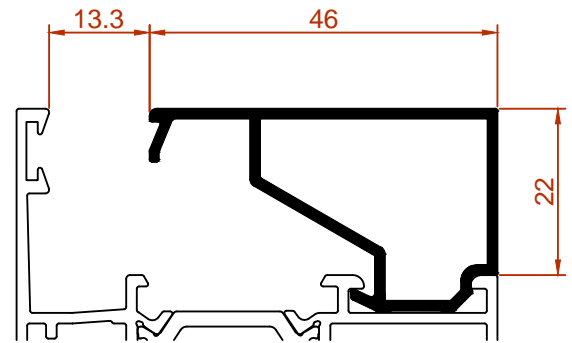

S90-67E

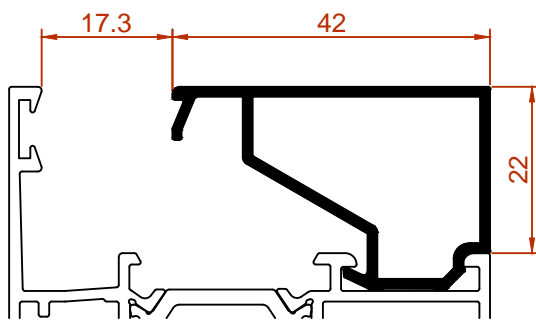

S90-68E

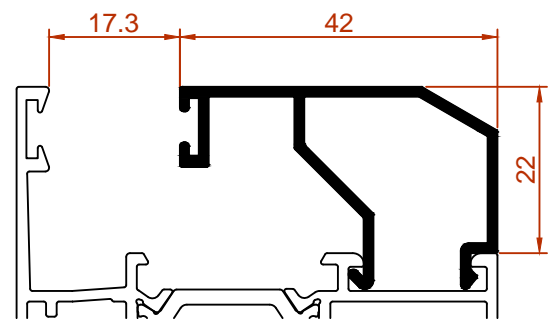

S90-95E

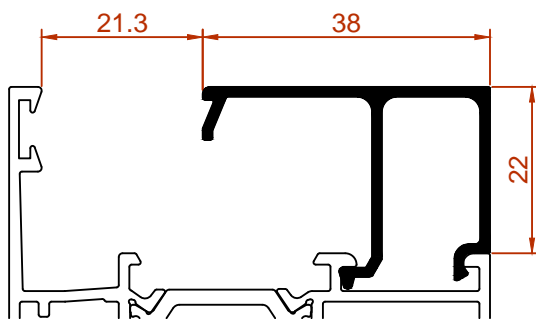

S90-65E

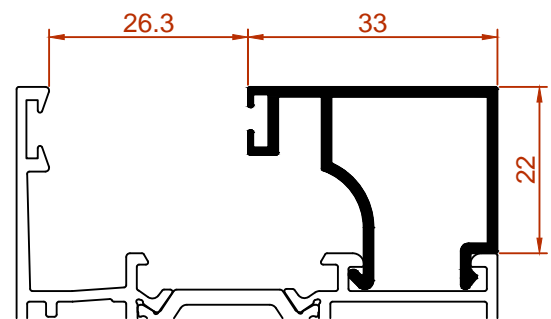

S90-50E

Perfiles escala 1:1

RT64 C16 - D9

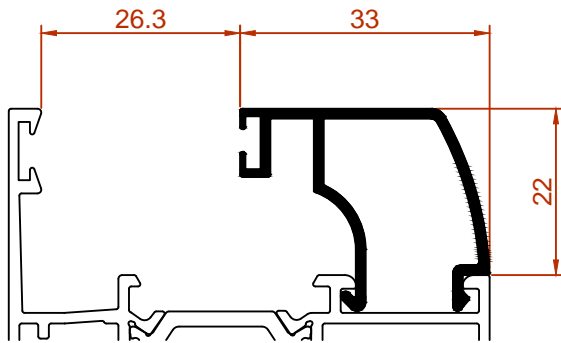

S90-90E

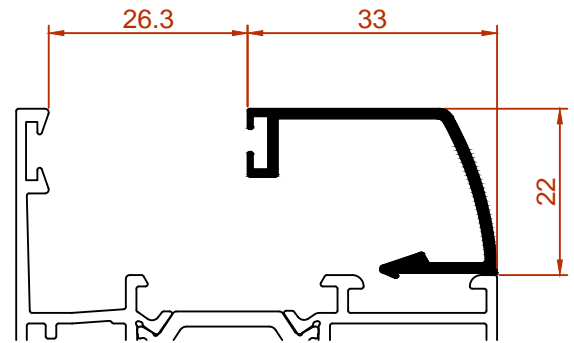

S90-91E

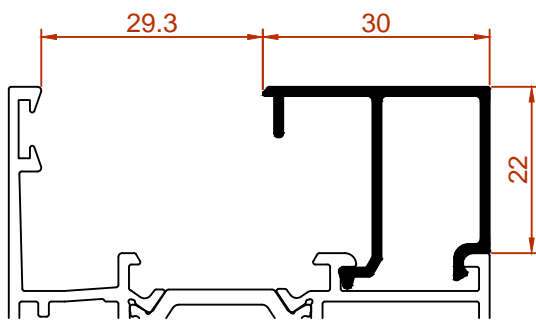

S90-54E

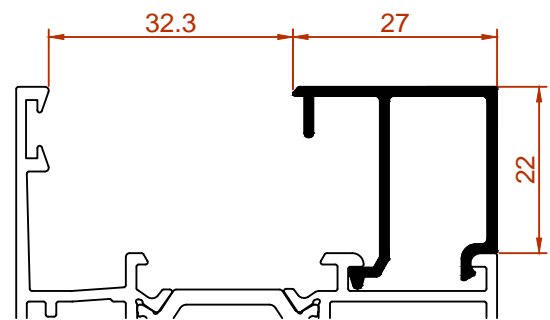

S90-56E

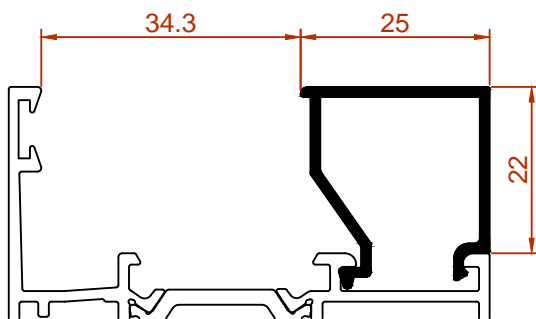

S90-51E

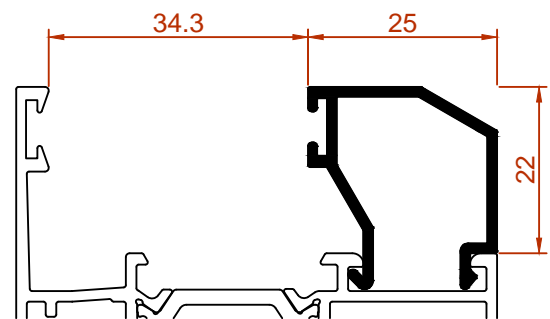

S90-94E

Perfiles escala 1:1

RT64 C16 - D10

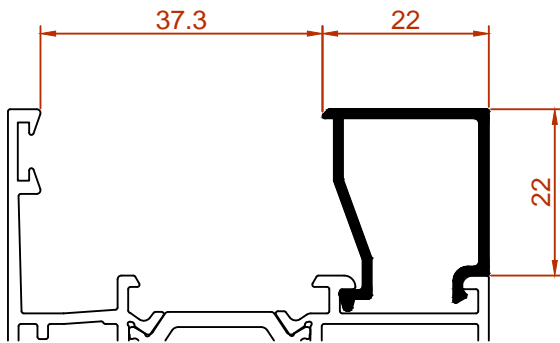

S90-64E

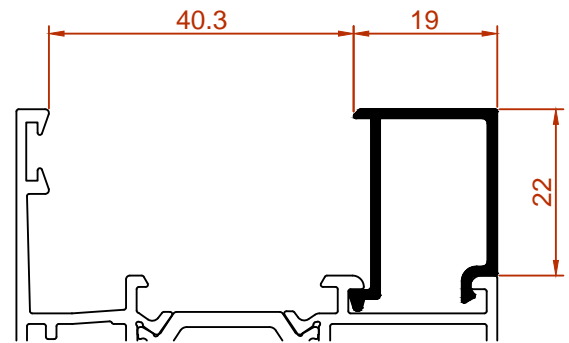

S90-52E

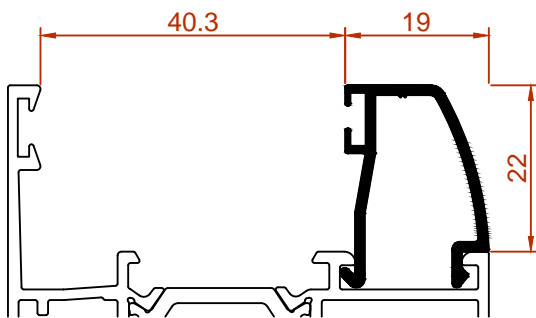

S90-96E

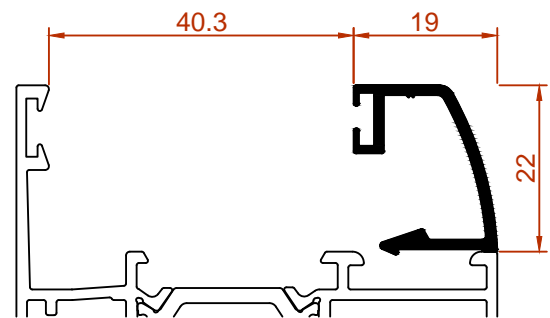

S90-97E

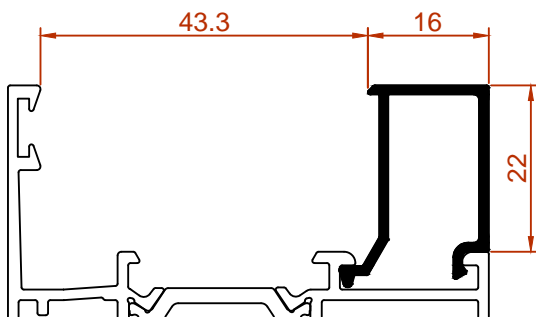

S90-57E

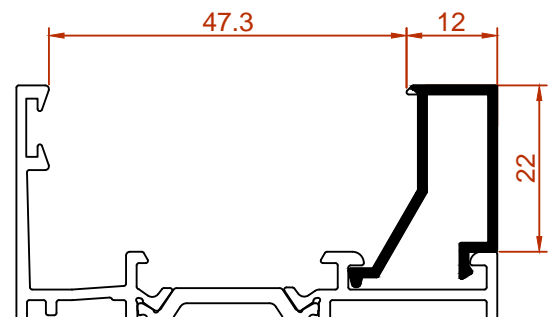

B90-55E

Perfiles escala 1:1

RT64 C16 - D11

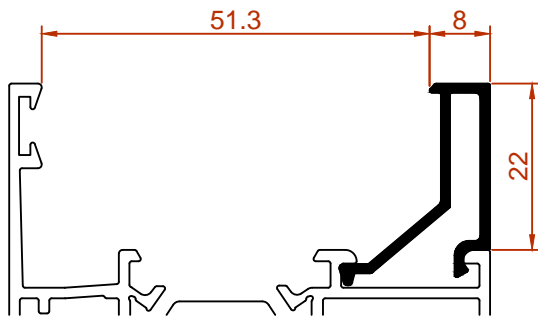

S90-58E

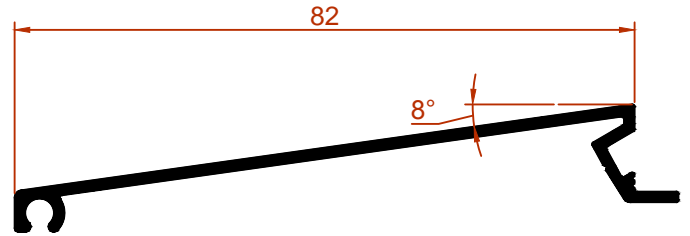

GALI-1106

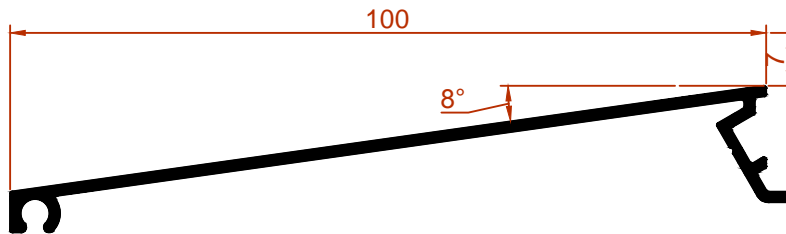

GALI-1119V

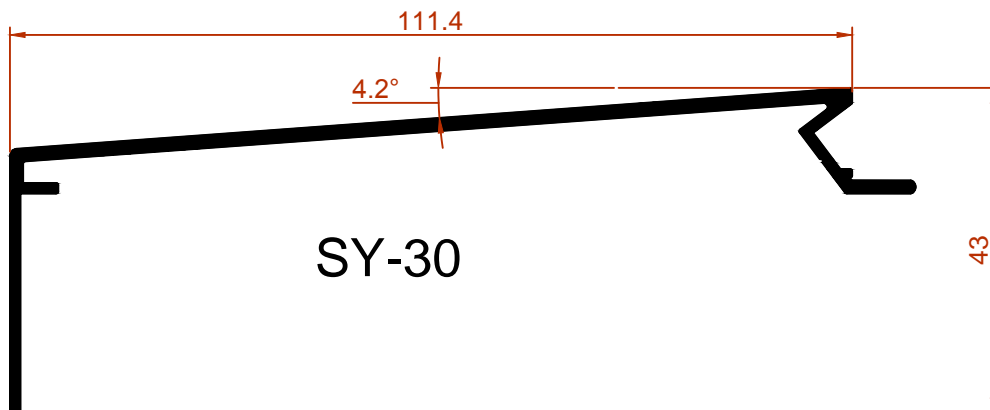

SY-30

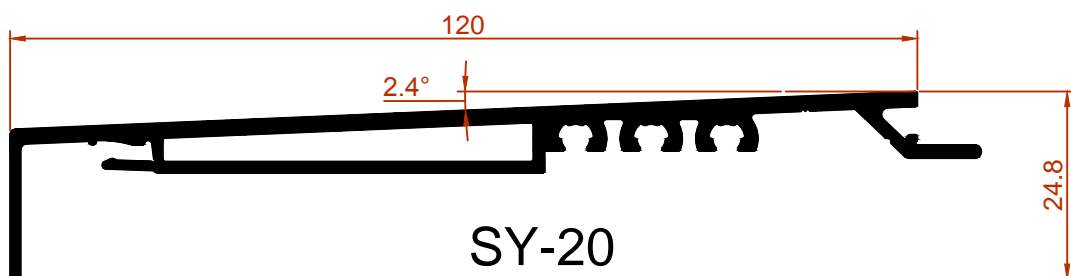

SY-20

Perfiles escala 1:1

RT64 C16 - D12

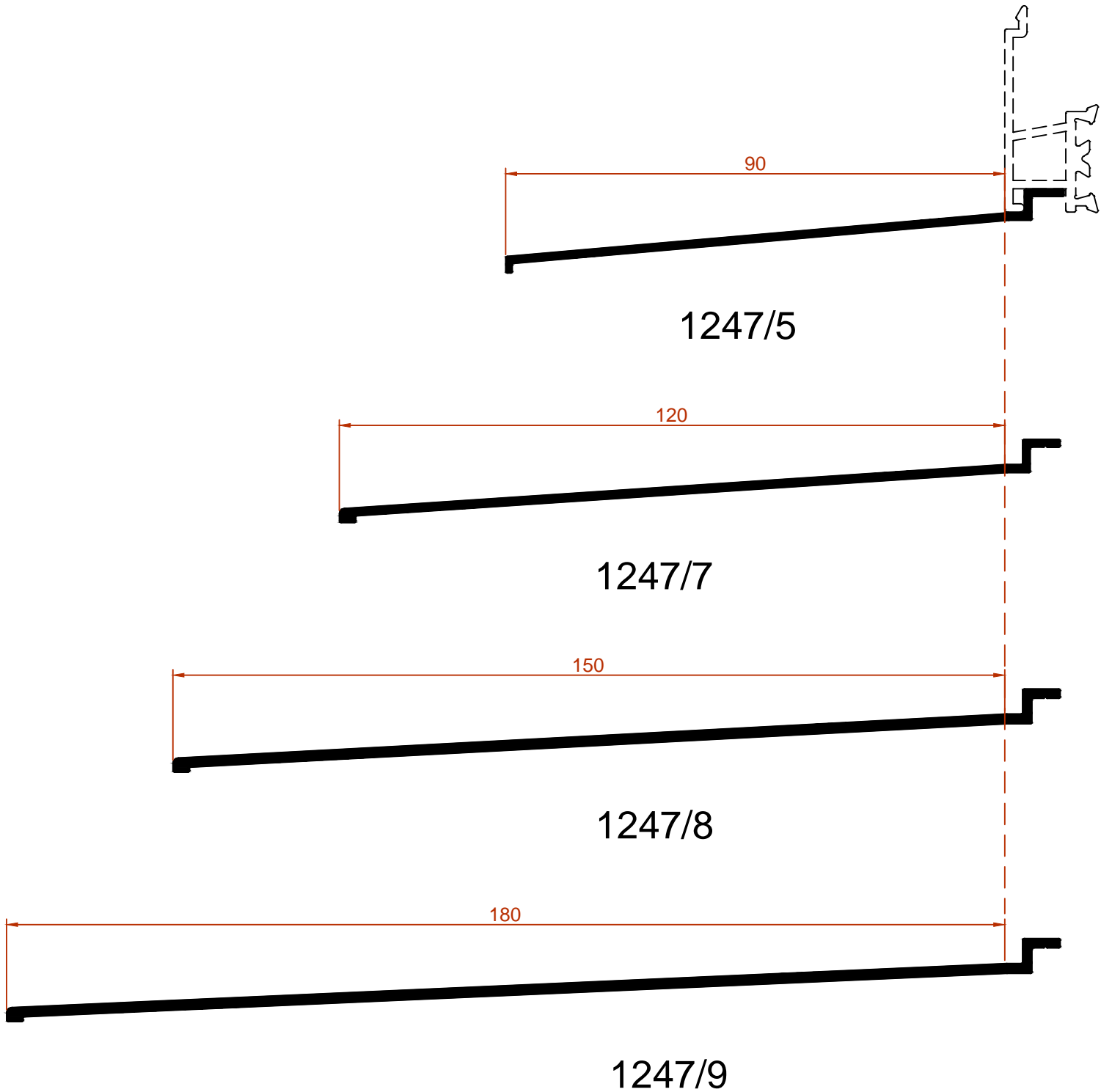

Perfiles escala 1:1

RT64 C16 - D13

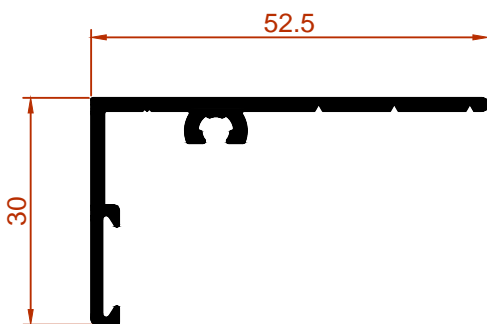
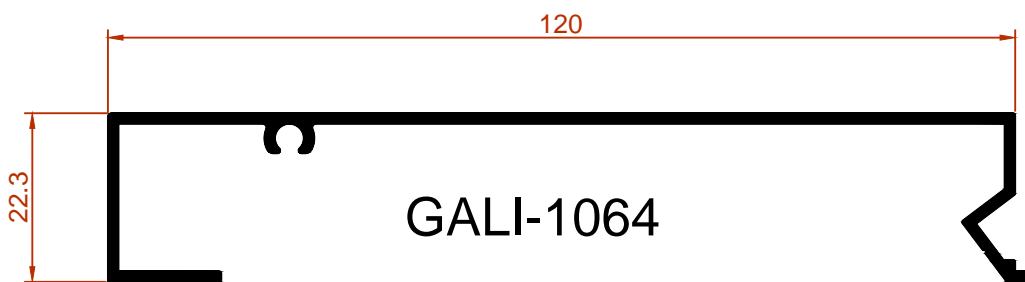
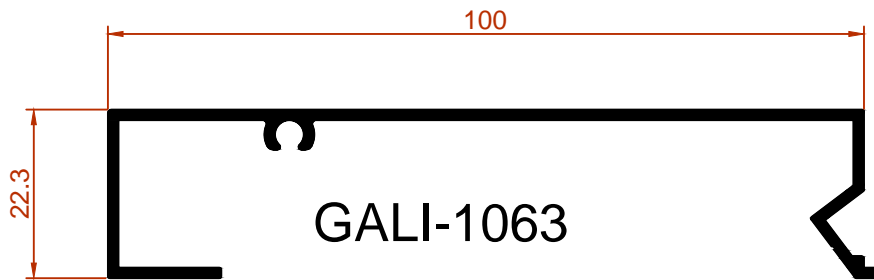

SY-11

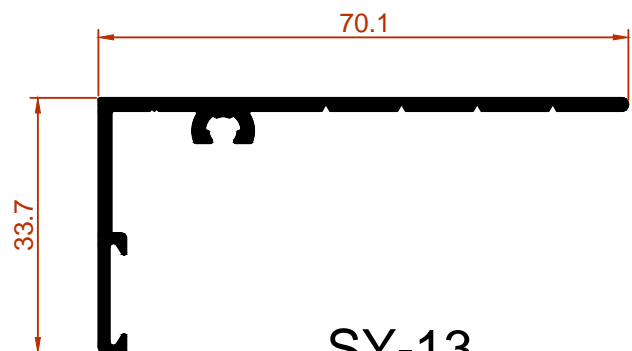

SY-13

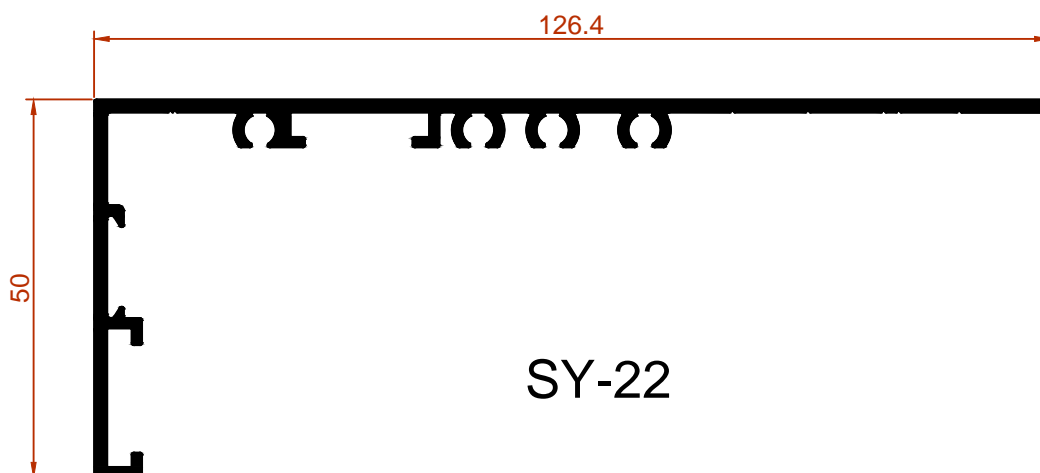

SY-22

Perfiles escala 1:1

RT64 C16 - D14

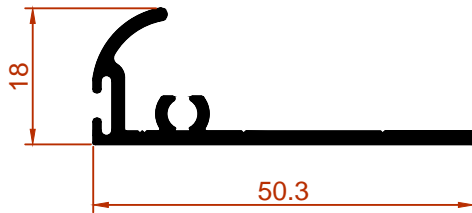

SY-21

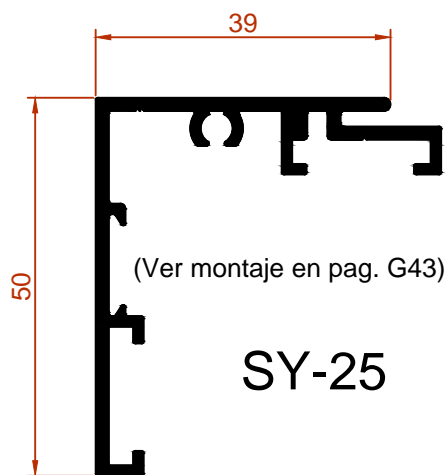

SY-25

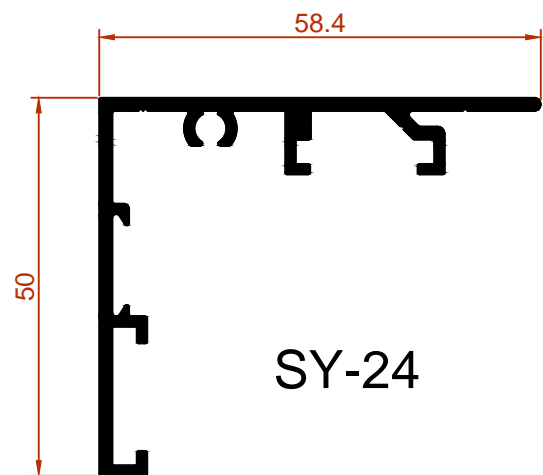

SY-24

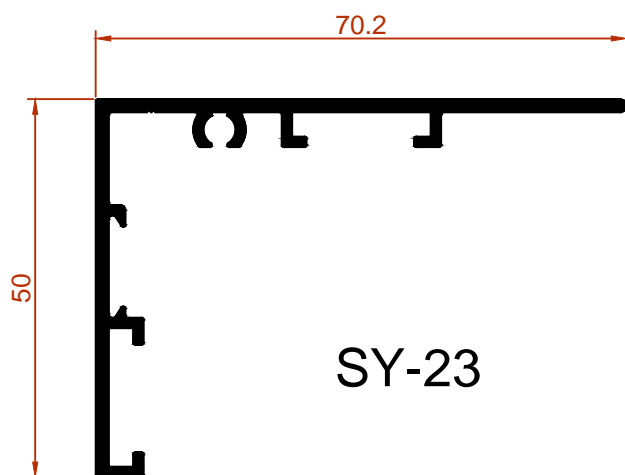

SY-23

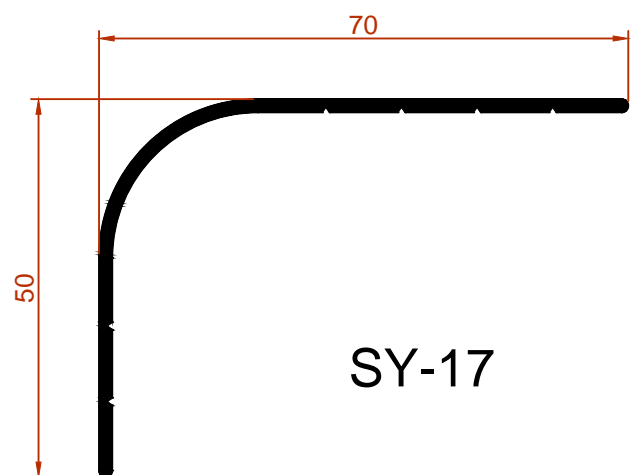

SY-17

Perfiles escala 1:1

RT64 C16 - D15

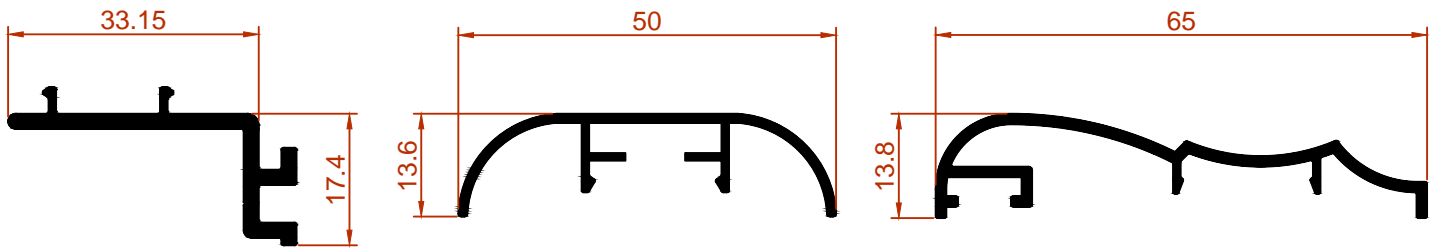

Gali-1006

GALI-1007

GALI-1078

(Ver montaje en pag. G42)

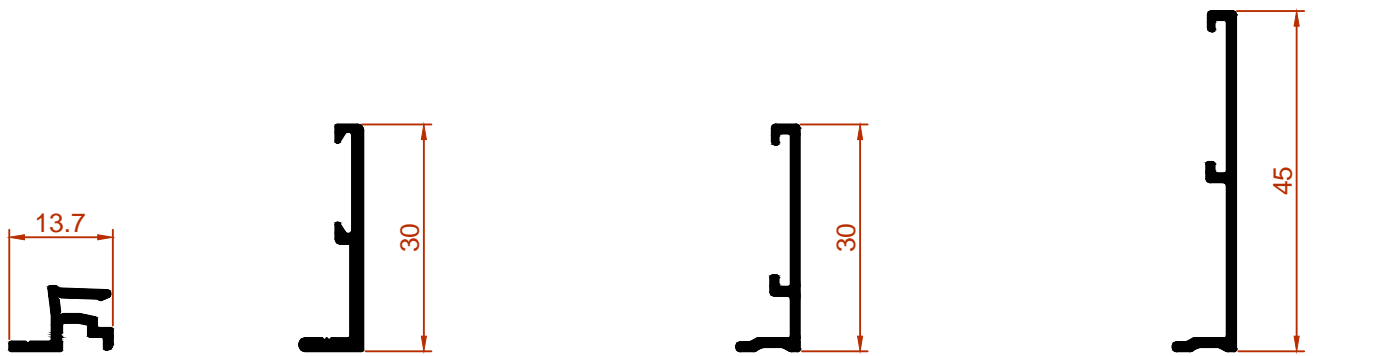

SY-26

SY-01

GALI-1116V

GALI-1118V

(Ver montaje en pag. G40 y siguientes)

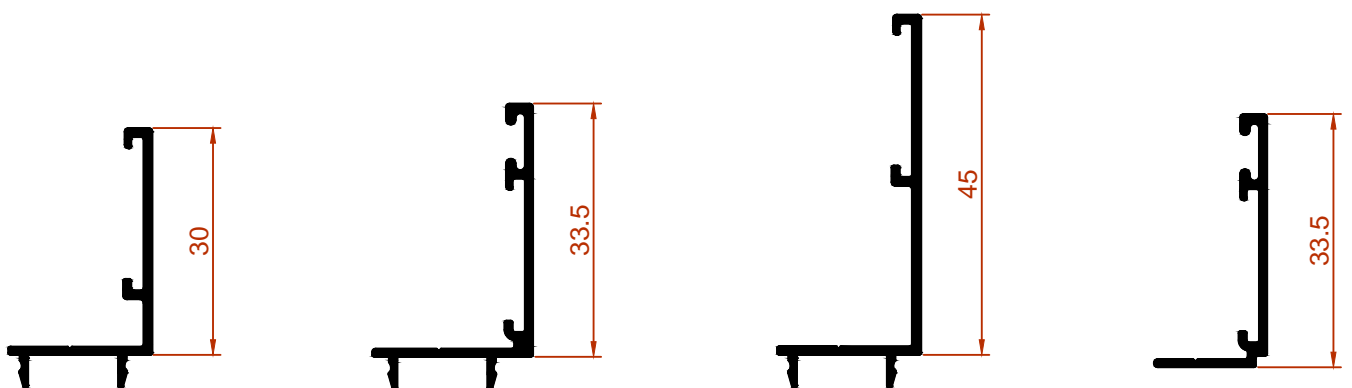

GALI-1115V

GALI-1085M

GALI-1117V

GALI-1086M

(Ver montaje en pag. G45)

Perfiles escala 1:1

RT64 C16 - D16

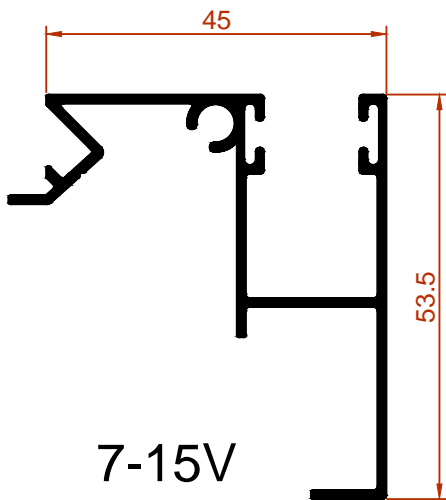

7-15V

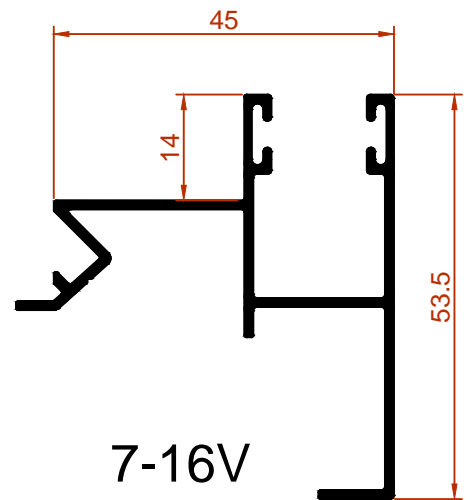

7-16V

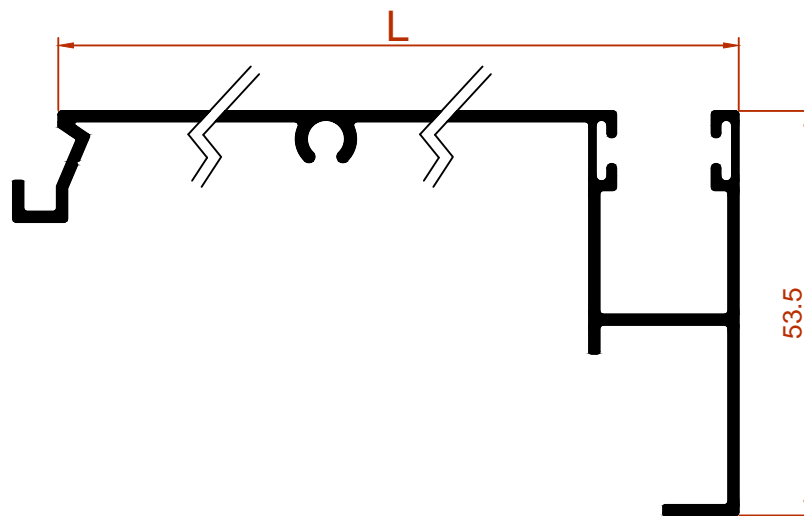

Referencia	Cota L
7-06	60
7-14	64,3
7-13	70
7-08	75
7-11	80

Referencia	Cota L
7-10	90
7-09	95
7-05	104
7-12	120

Perfiles escala 1:1

RT64 C16 - D17

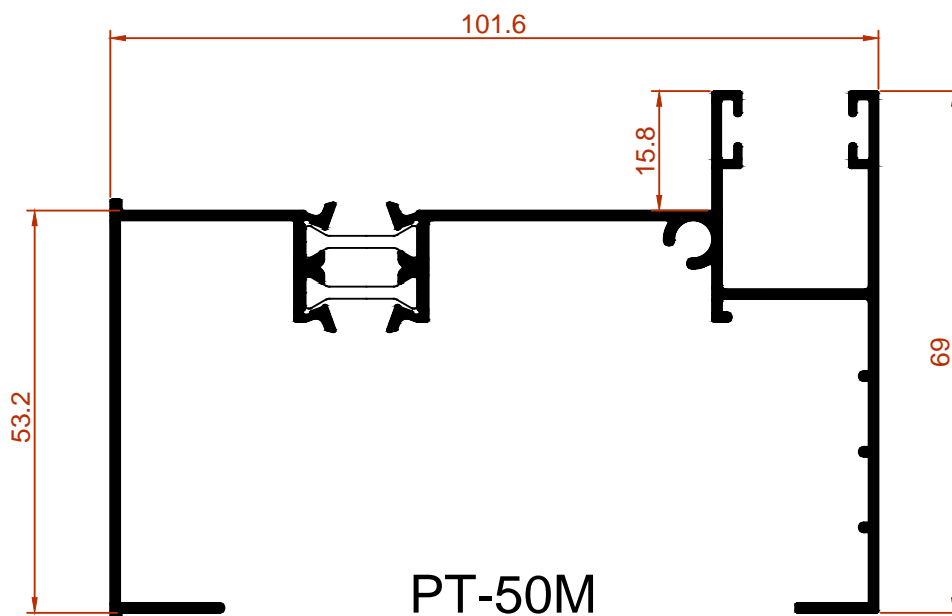
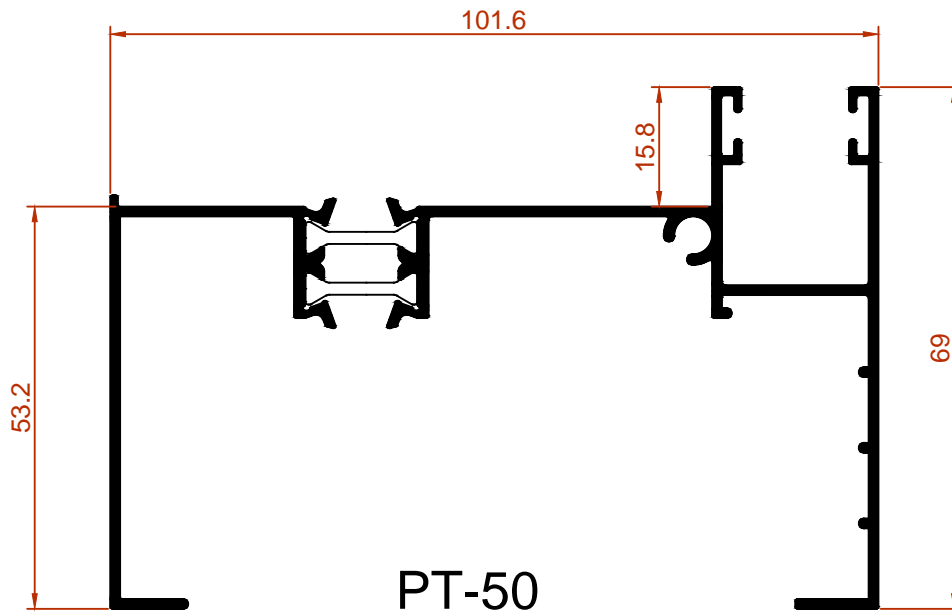

Perfiles escala 1:1

RT64 C16 - D18

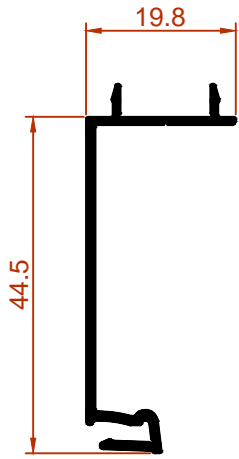

GALI-1120V

(Ver montaje en pag. G40 y siguientes)

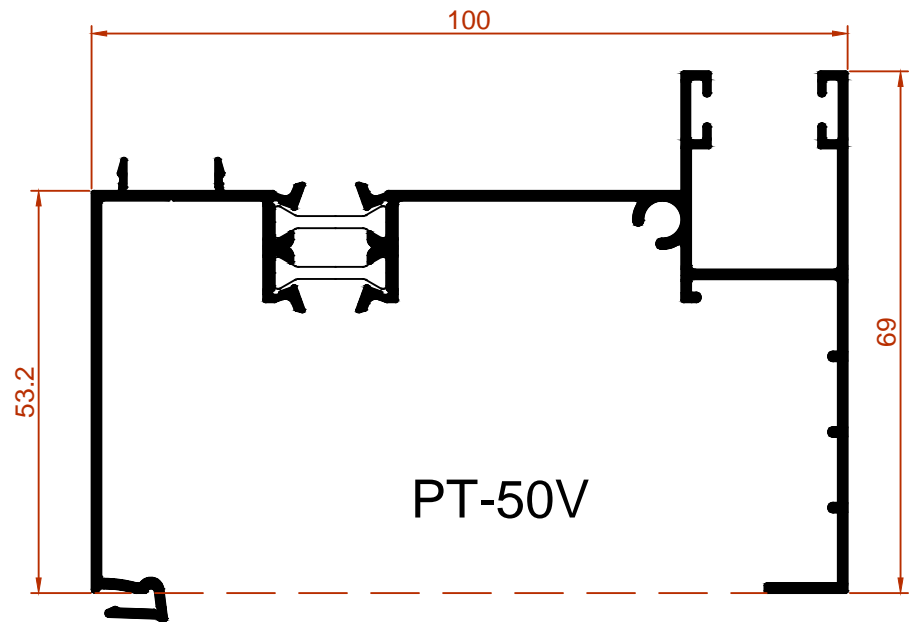

PT-50V

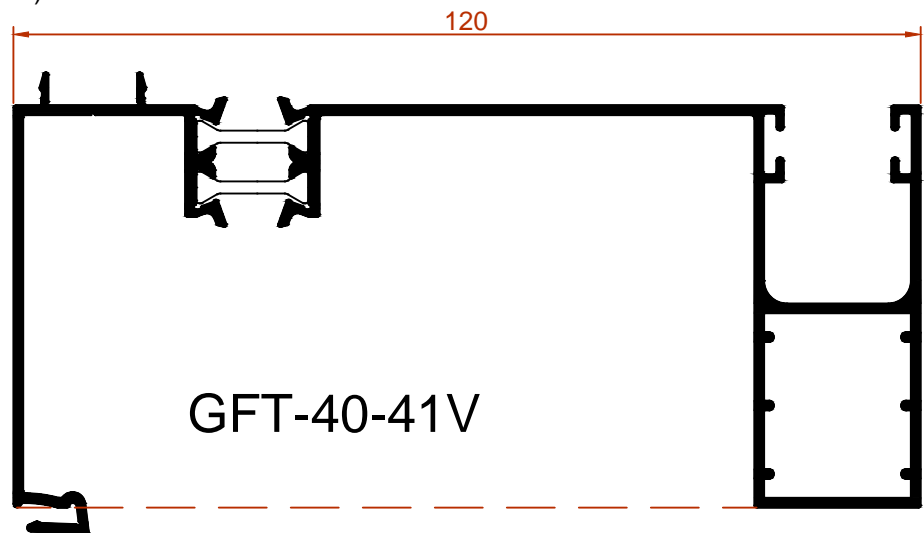

GFT-40-41V

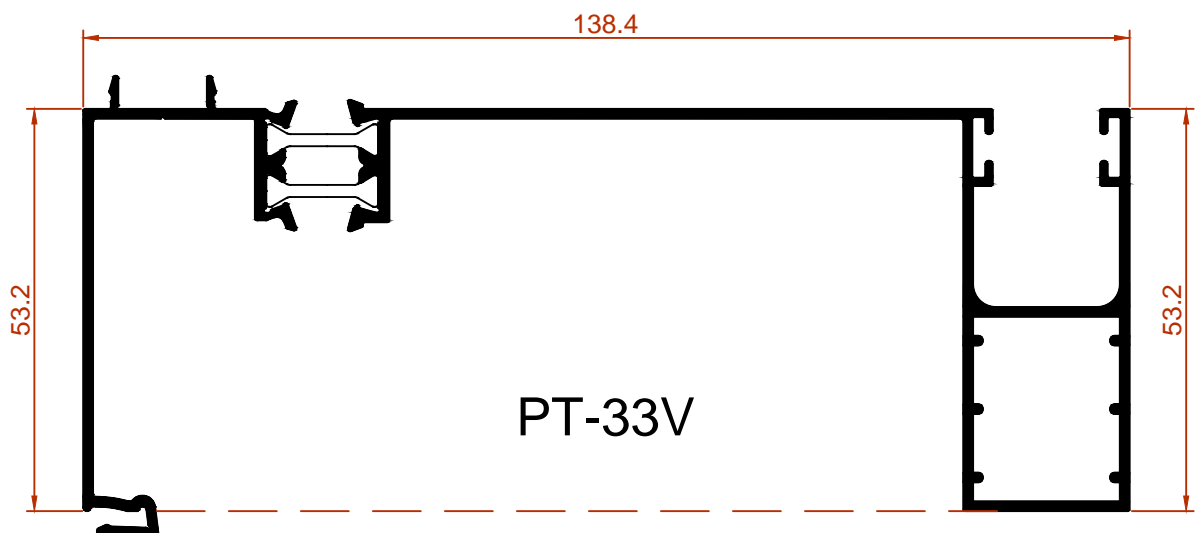

PT-33V

APERTURA INTERIOR

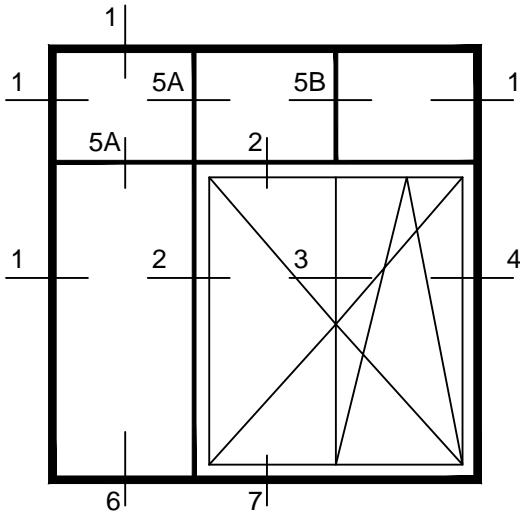

Ventanas

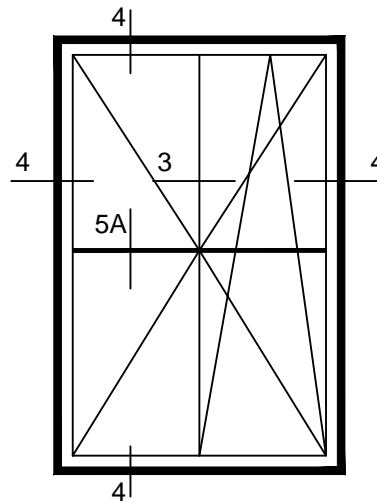

Balconera

APERTURA EXTERIOR

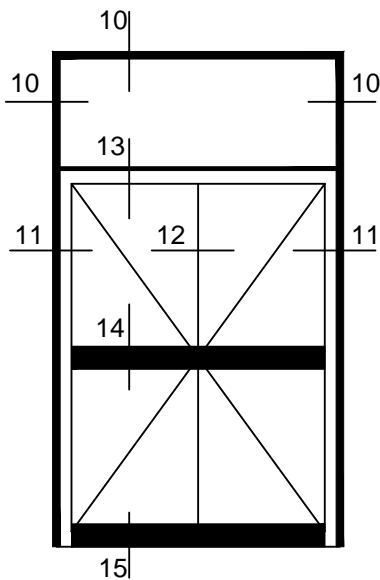

Puerta entrada

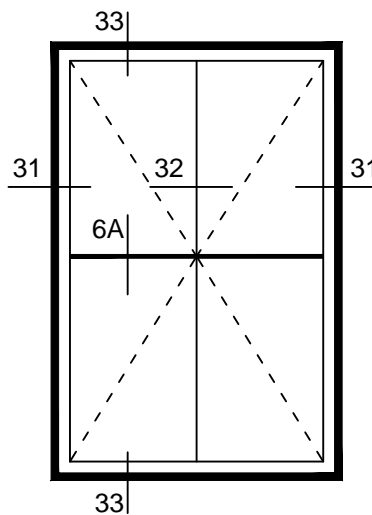

Balconera

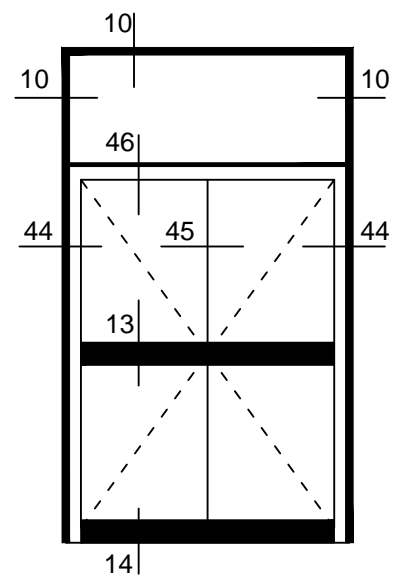

Puerta entrada

Secciones tipo

RT64 C16E - G3

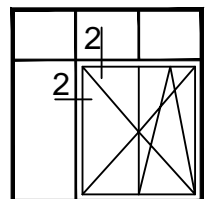
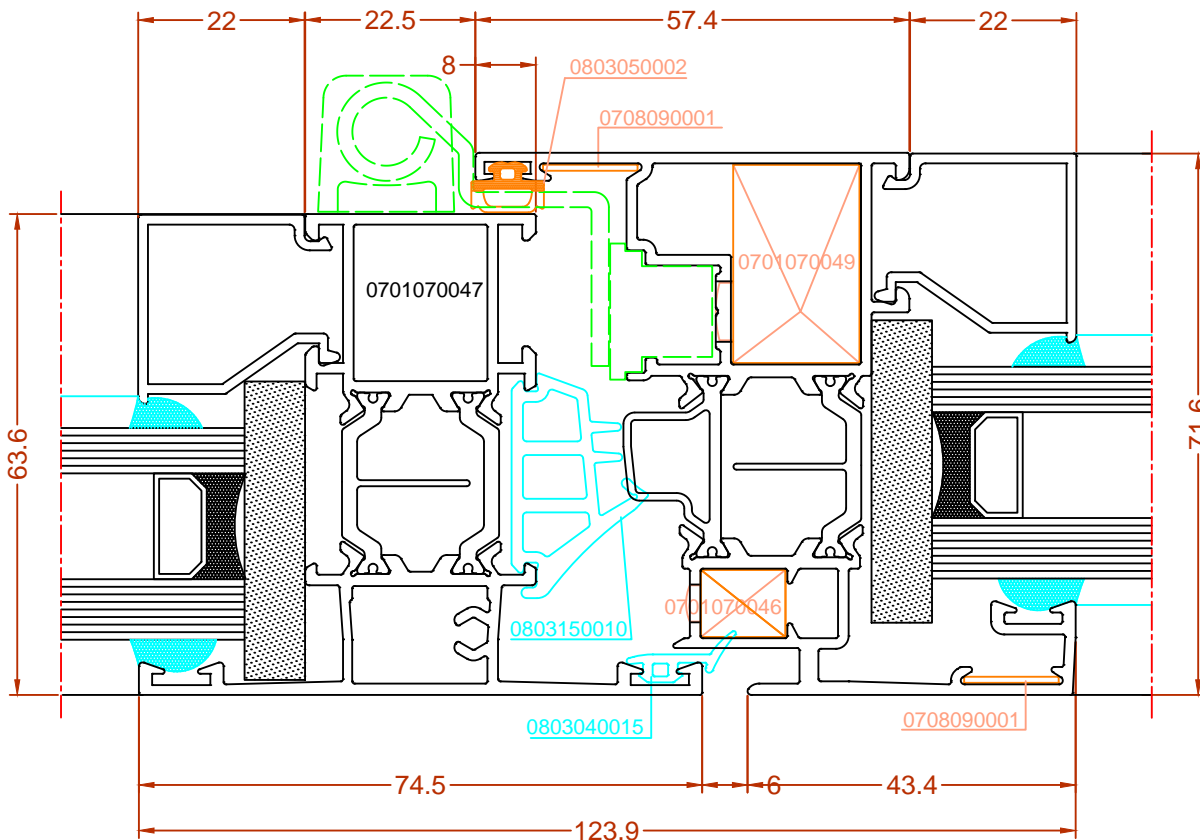
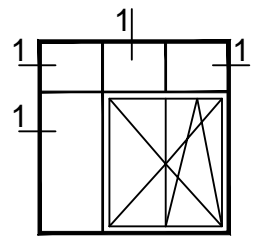
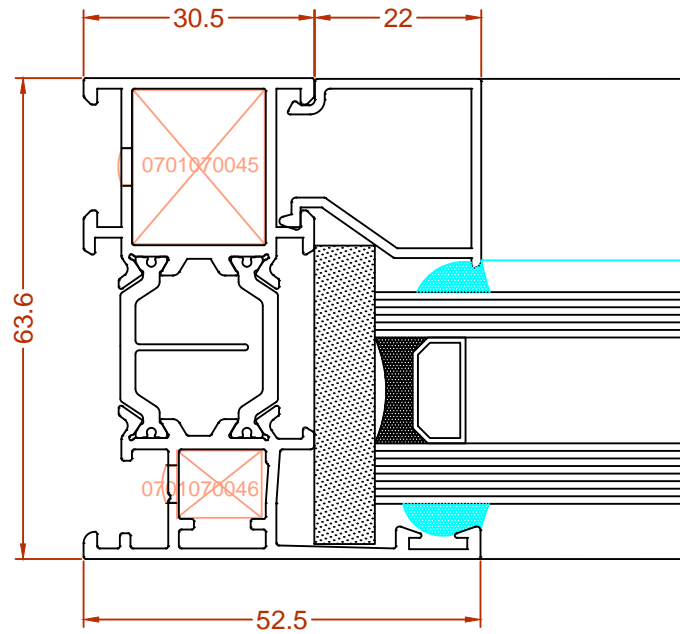

Secciones tipo

RT64 C16 - G4

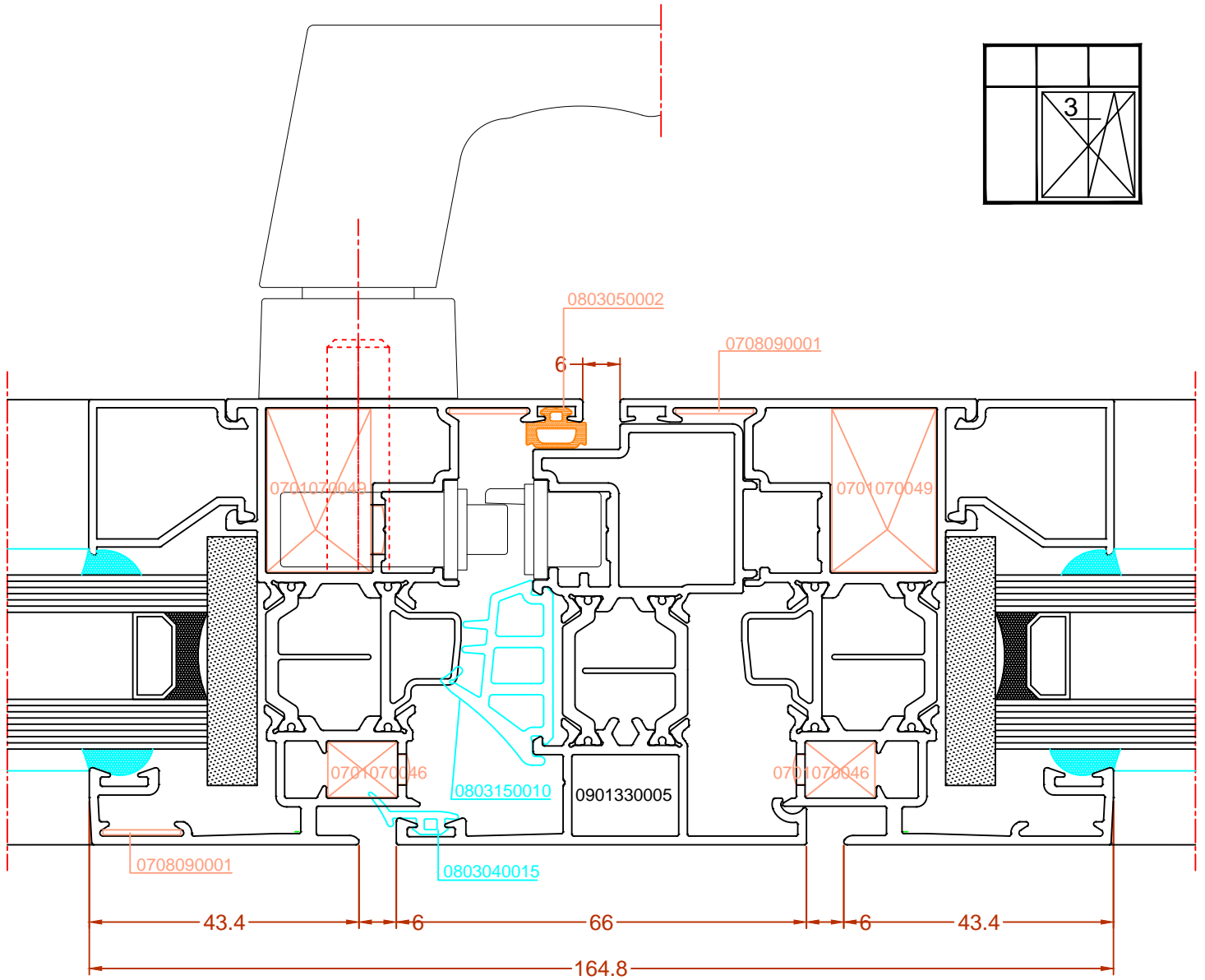

Secciones tipo

RT64 C16 - G5

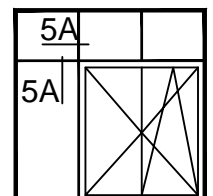
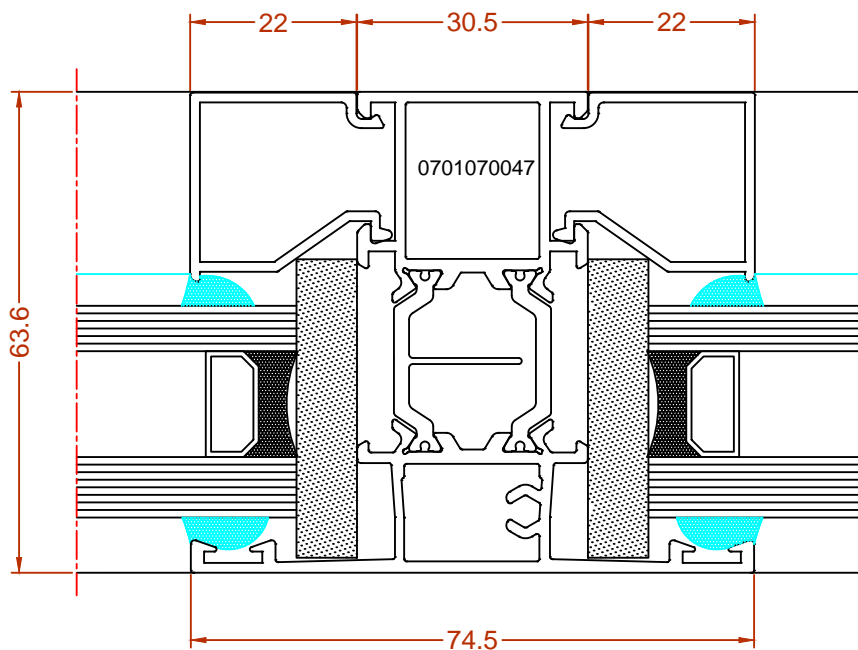
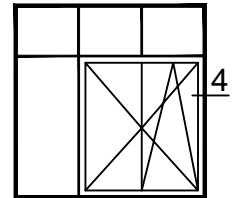
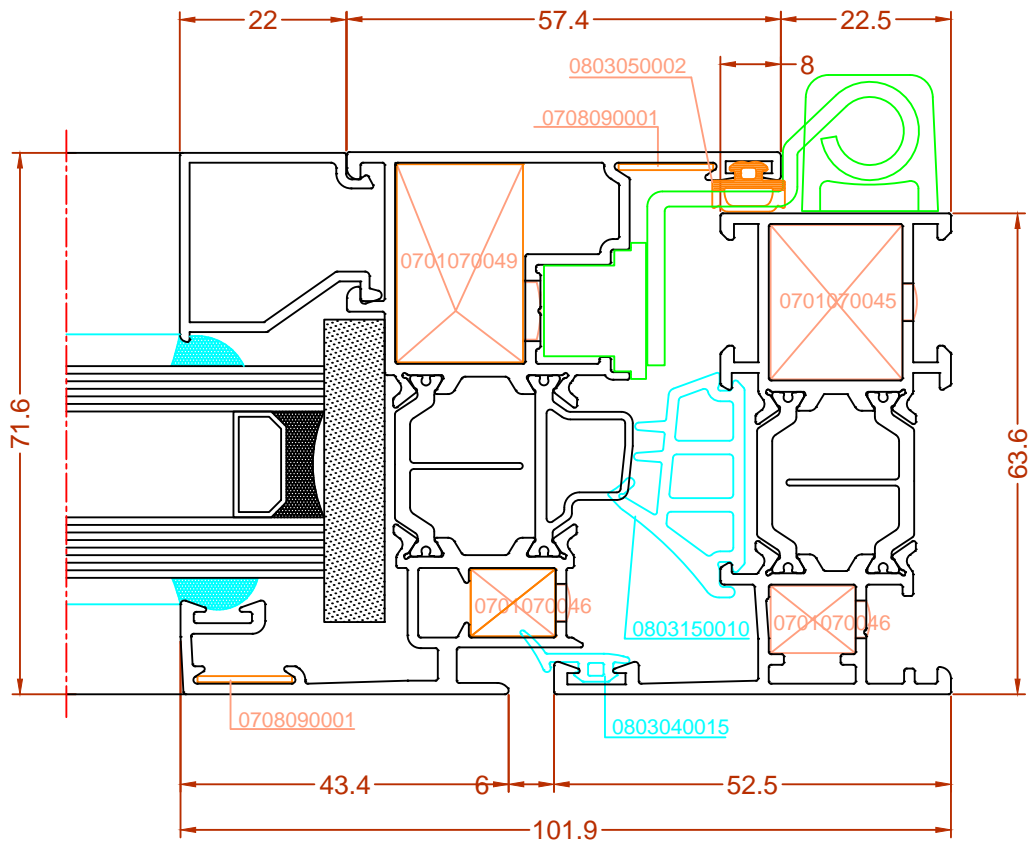

Secciones tipo

RT64 C16E - G6

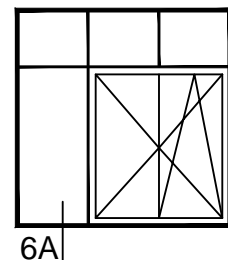
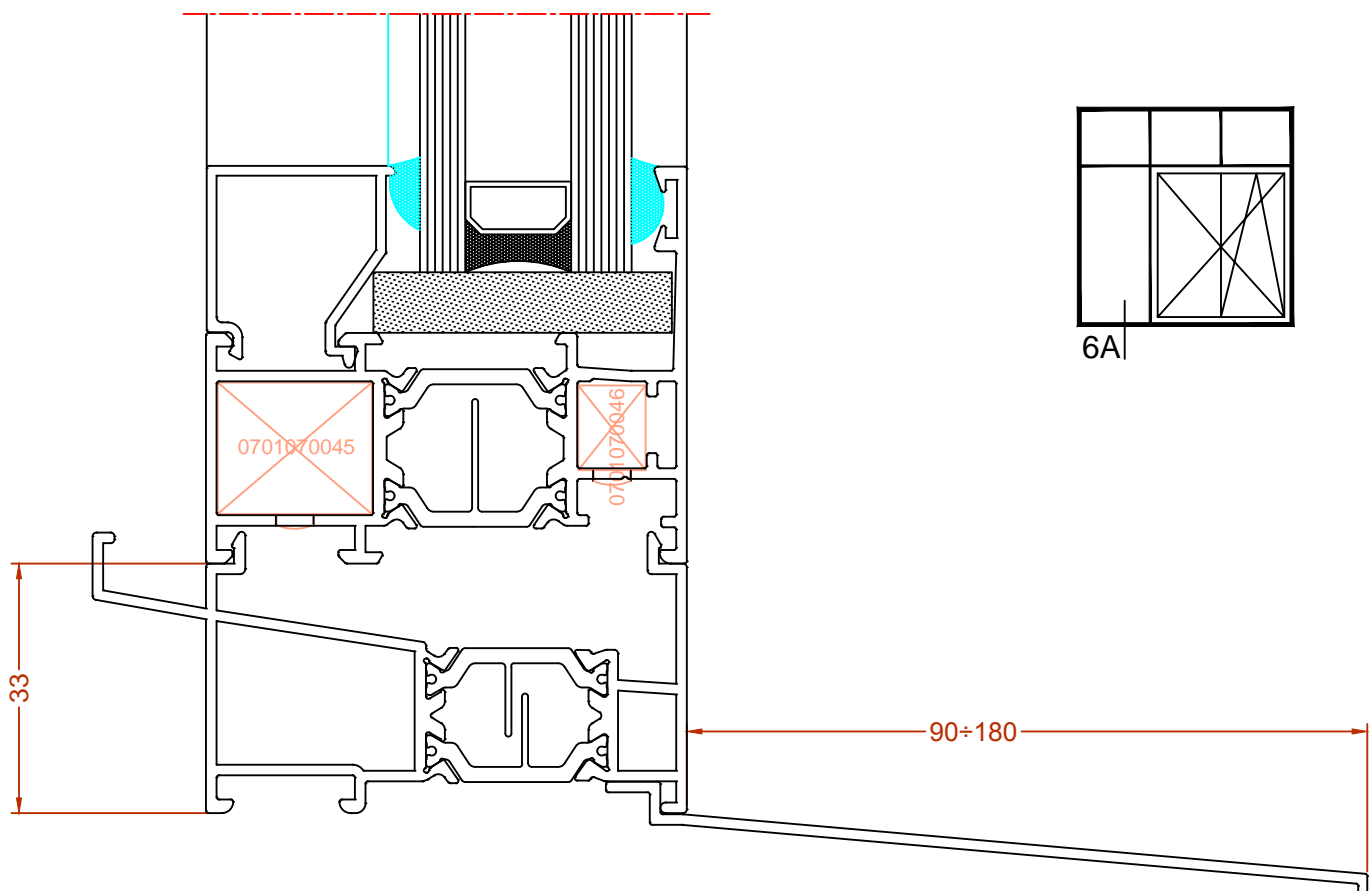
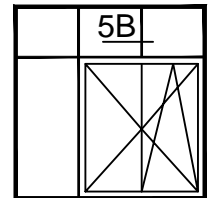
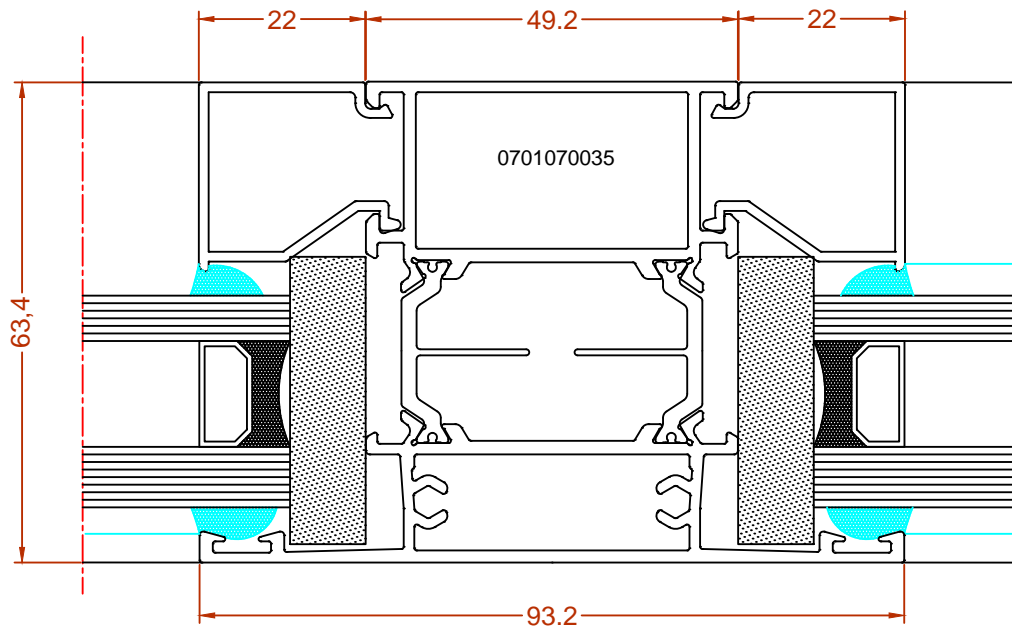

Secciones tipo

RT64 C16 - G7

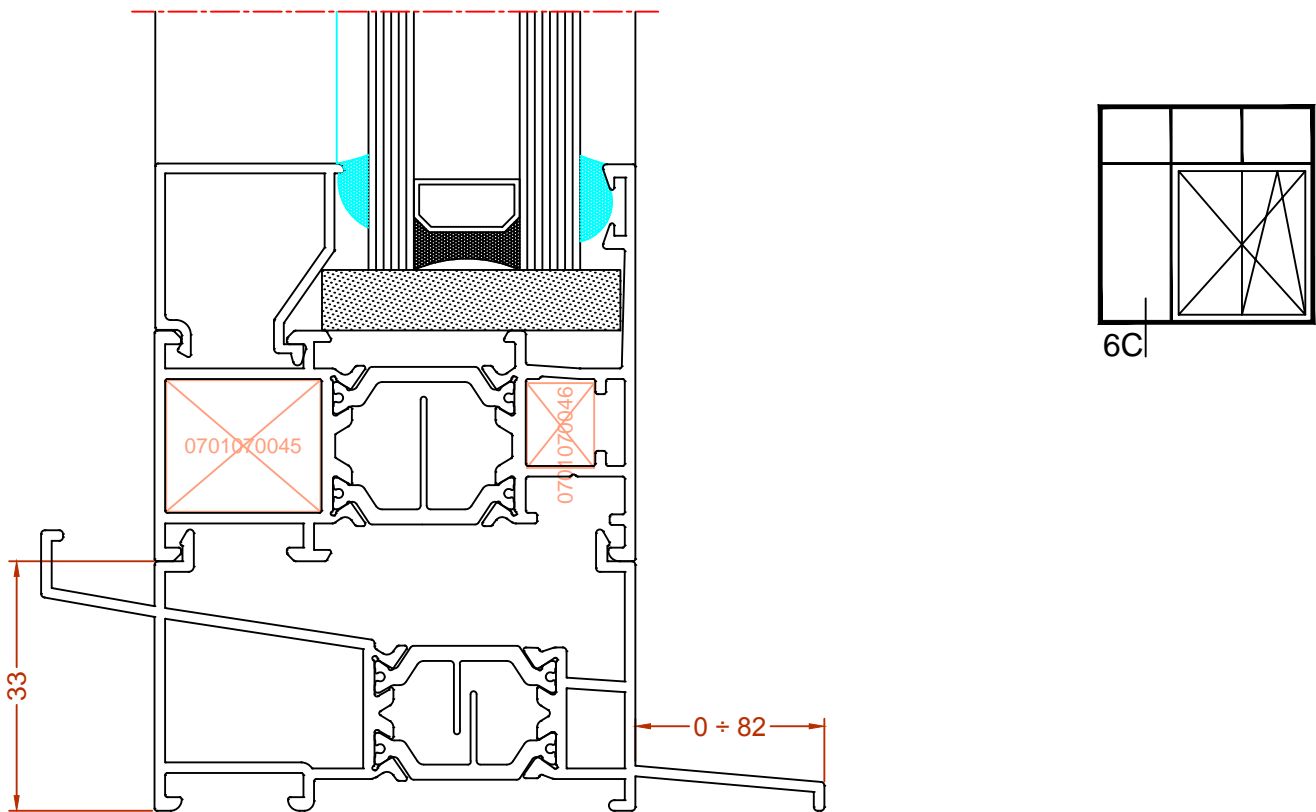
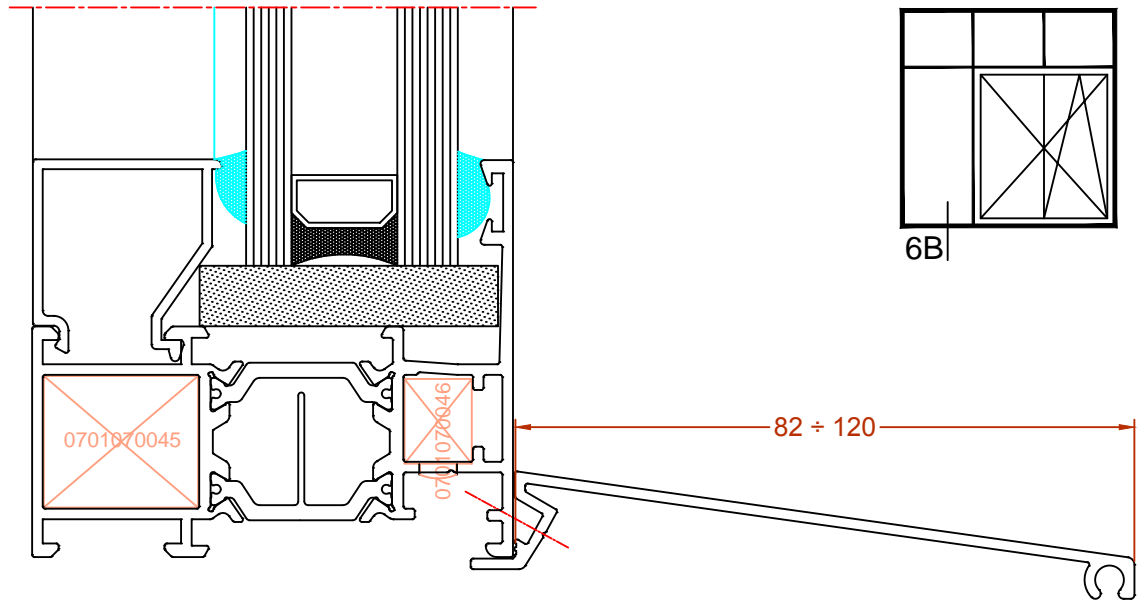

Secciones tipo

RT64 C16 - G8

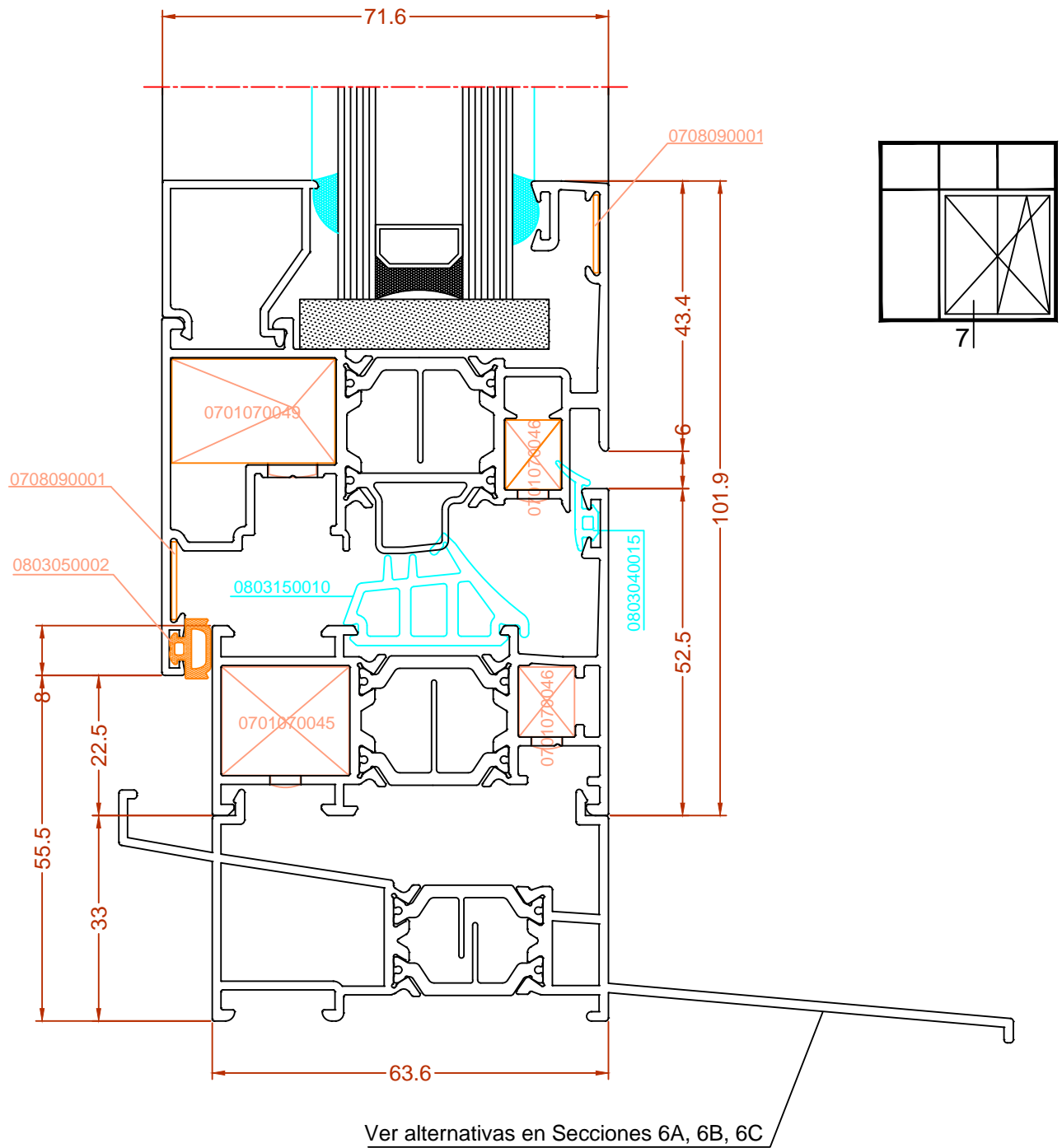

Secciones tipo

RT64 C16 - G9

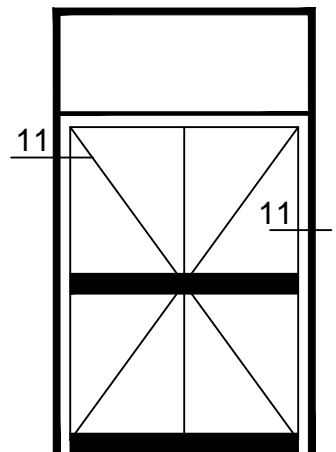
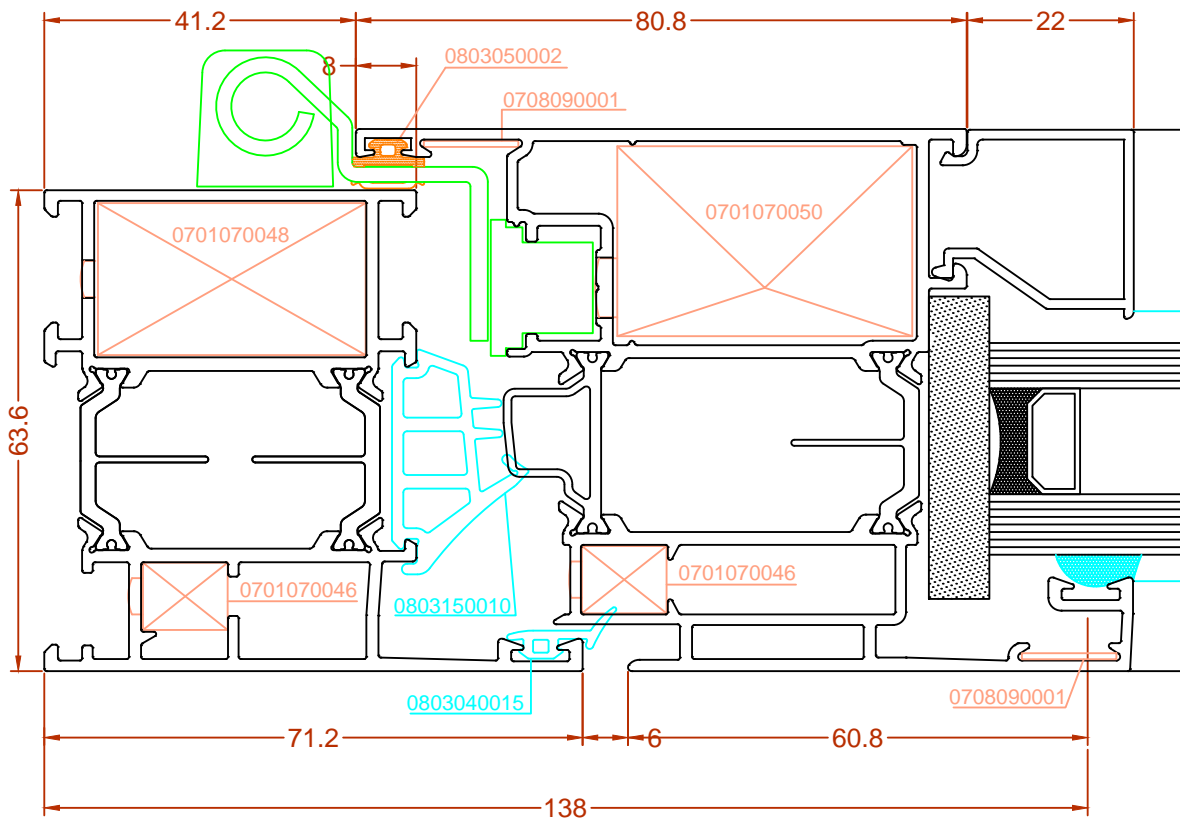
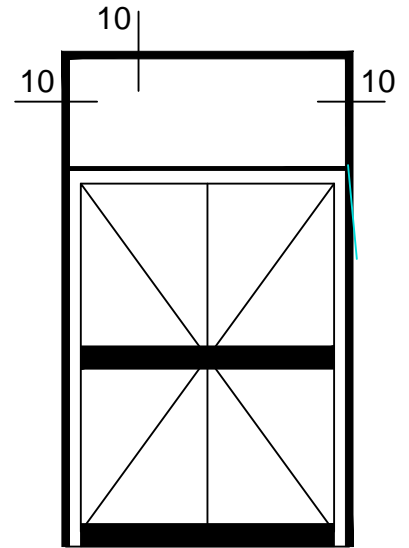
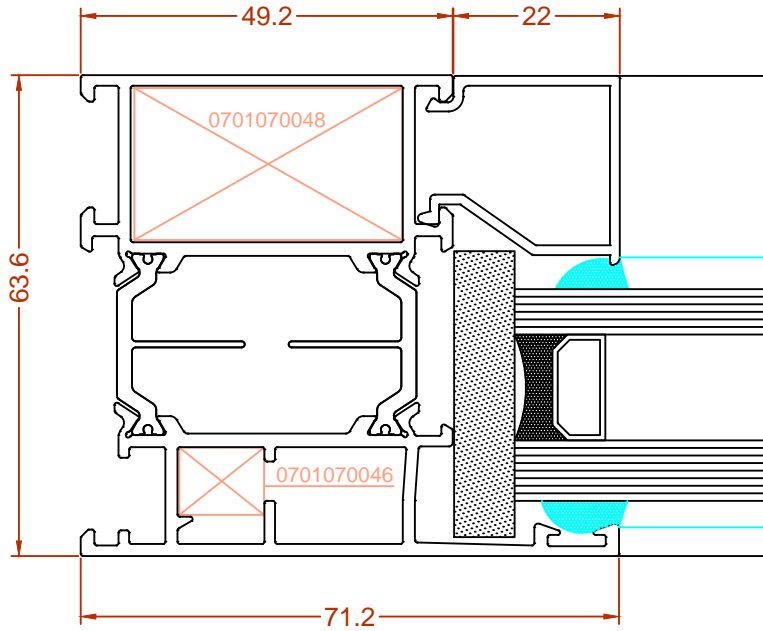

Secciones tipo

RT64 C16 - G10

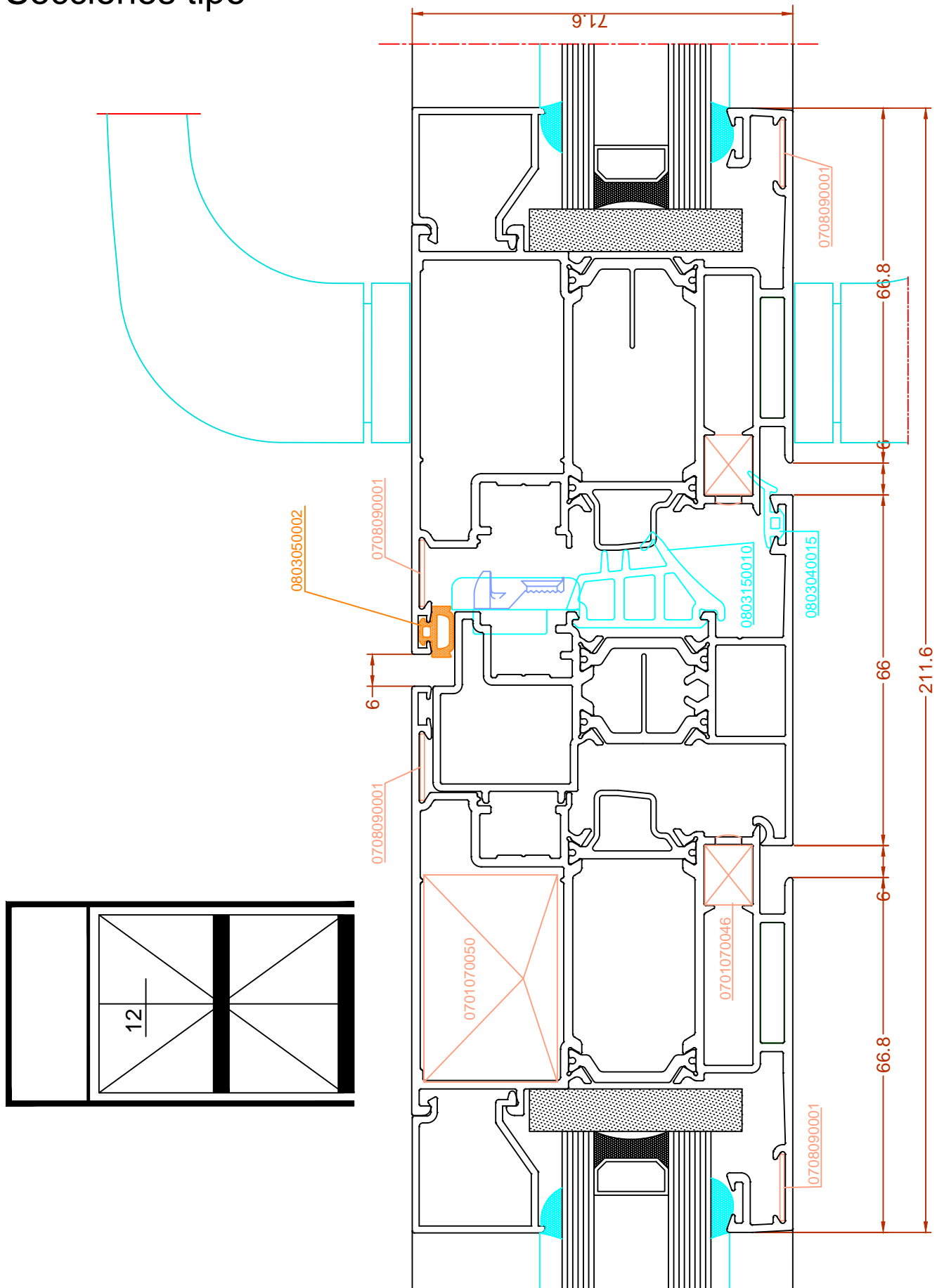

Secciones tipo

RT64 C16 - G11

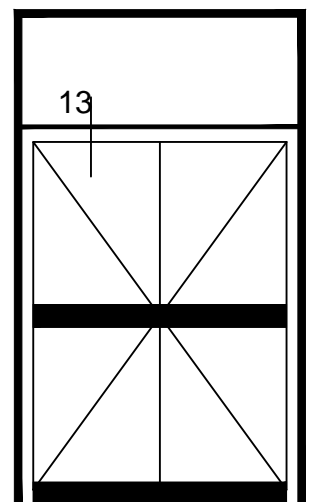
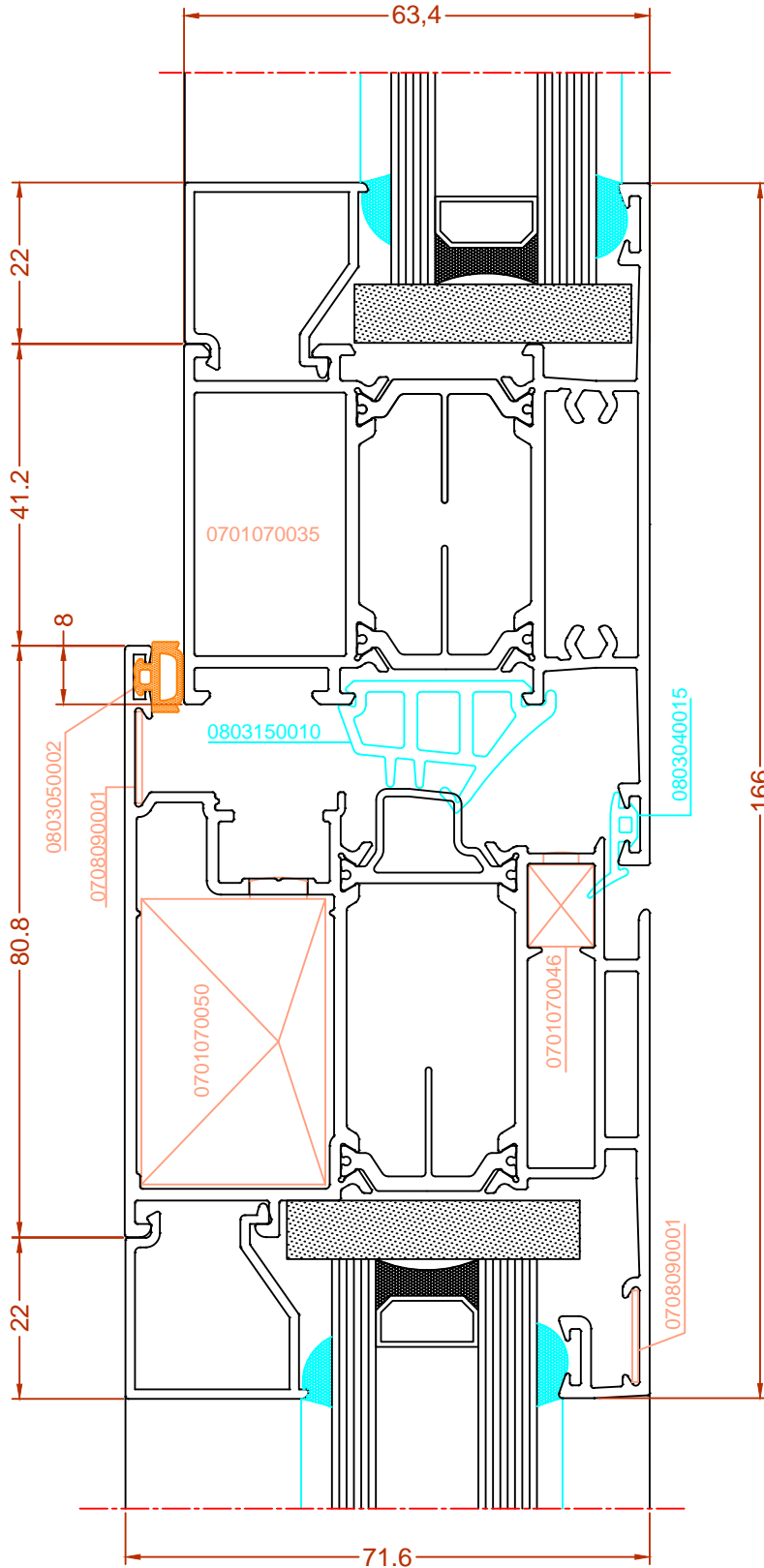

Secciones tipo

RT64 C16 - G12

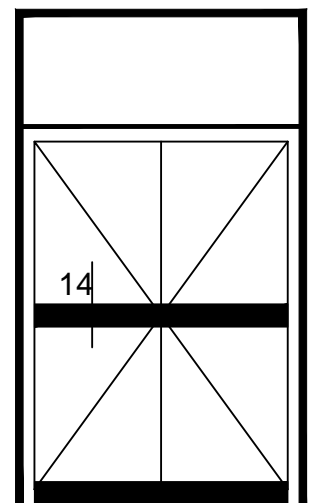
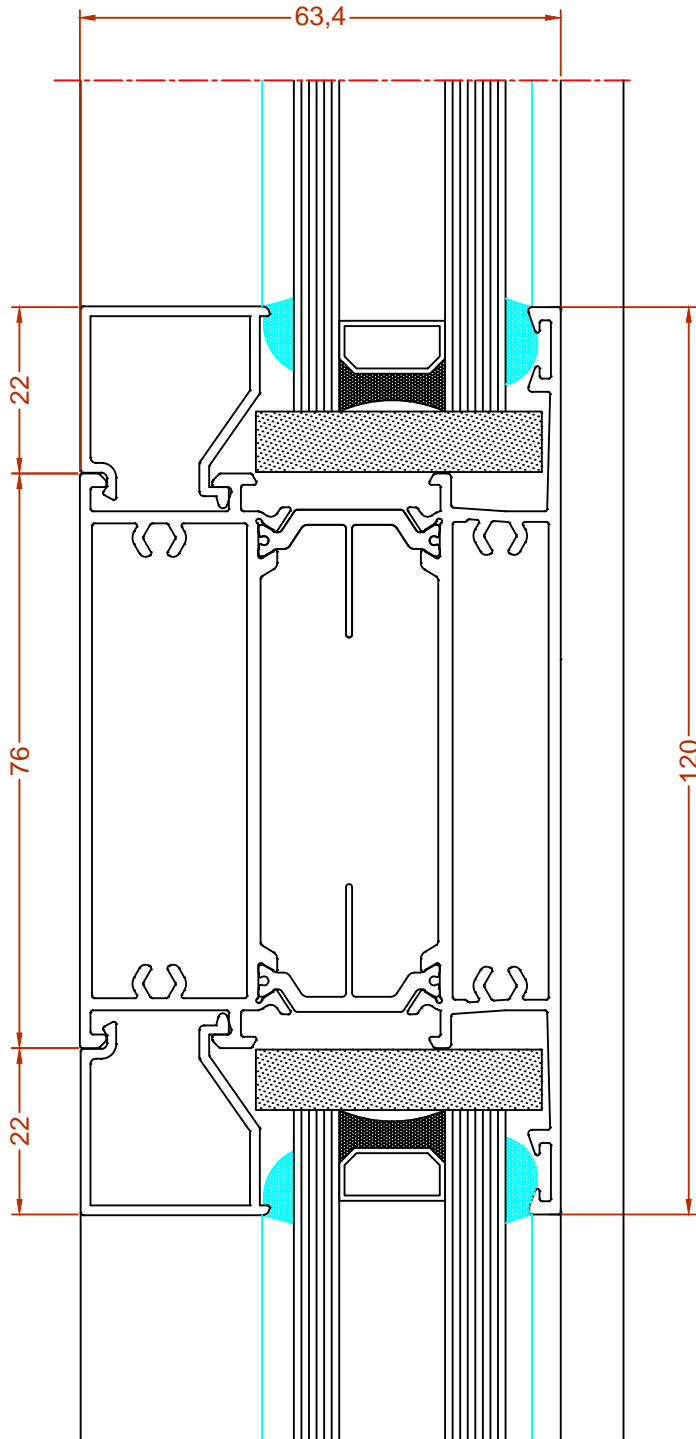

Secciones tipo

RT64 C16 - G13

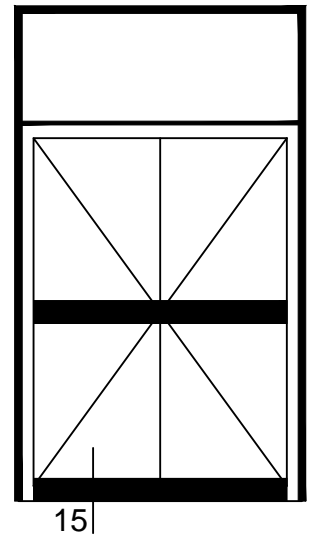
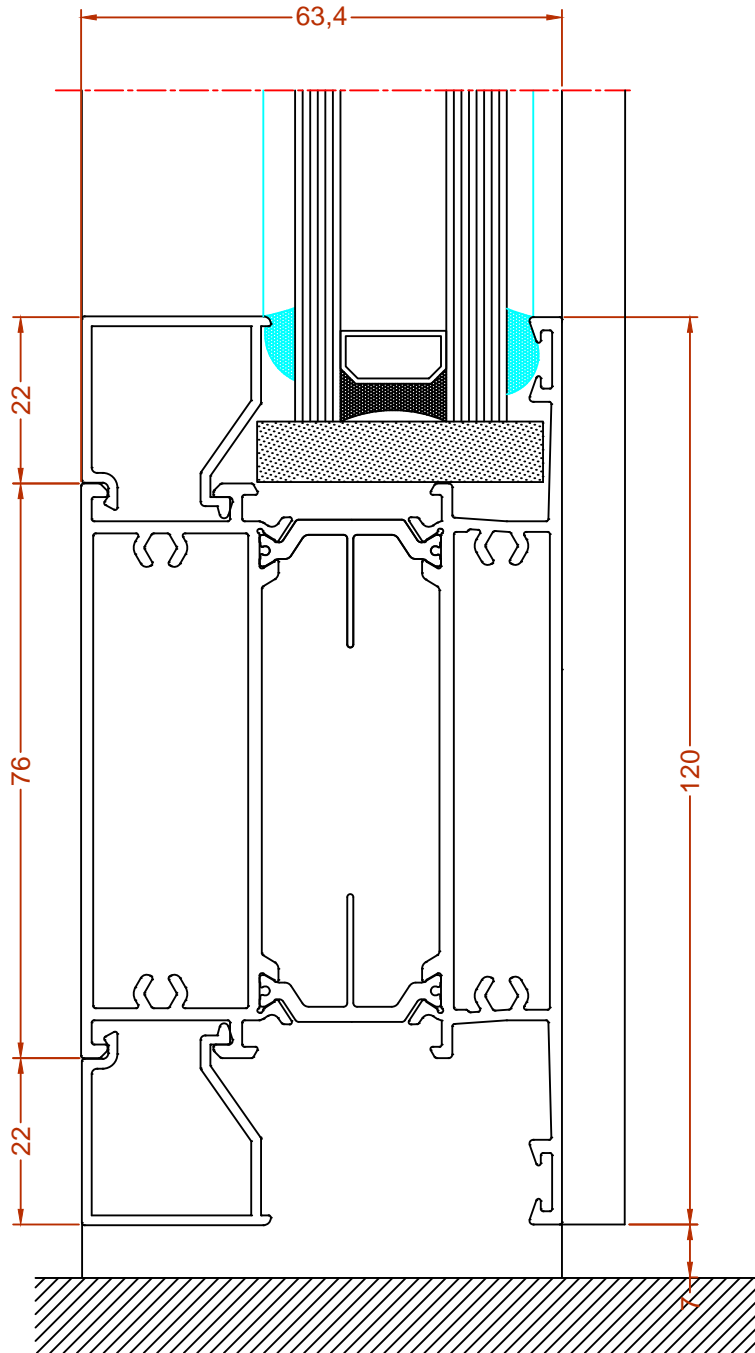

Secciones tipo

RT64 C16 - G14

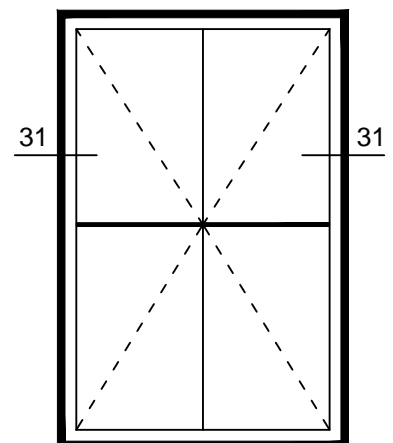
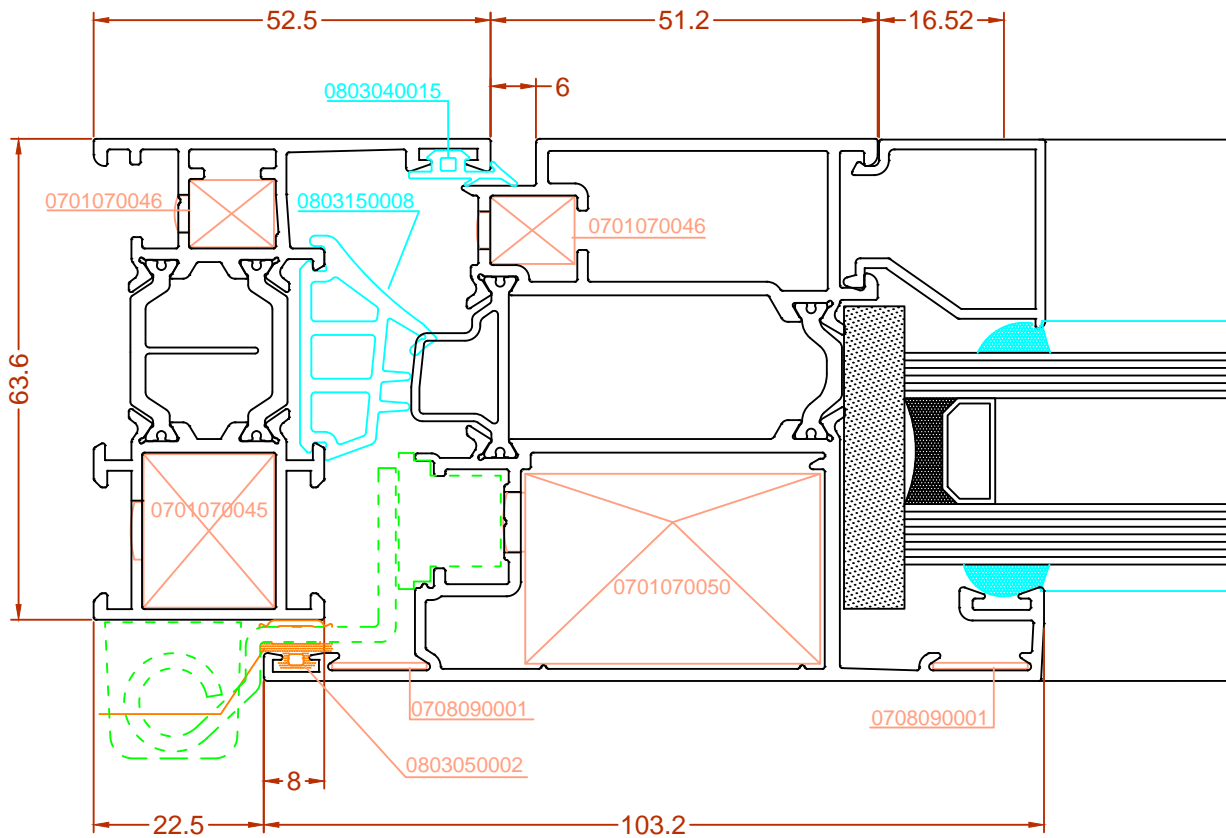

Secciones tipo

RT64 C16 - G15

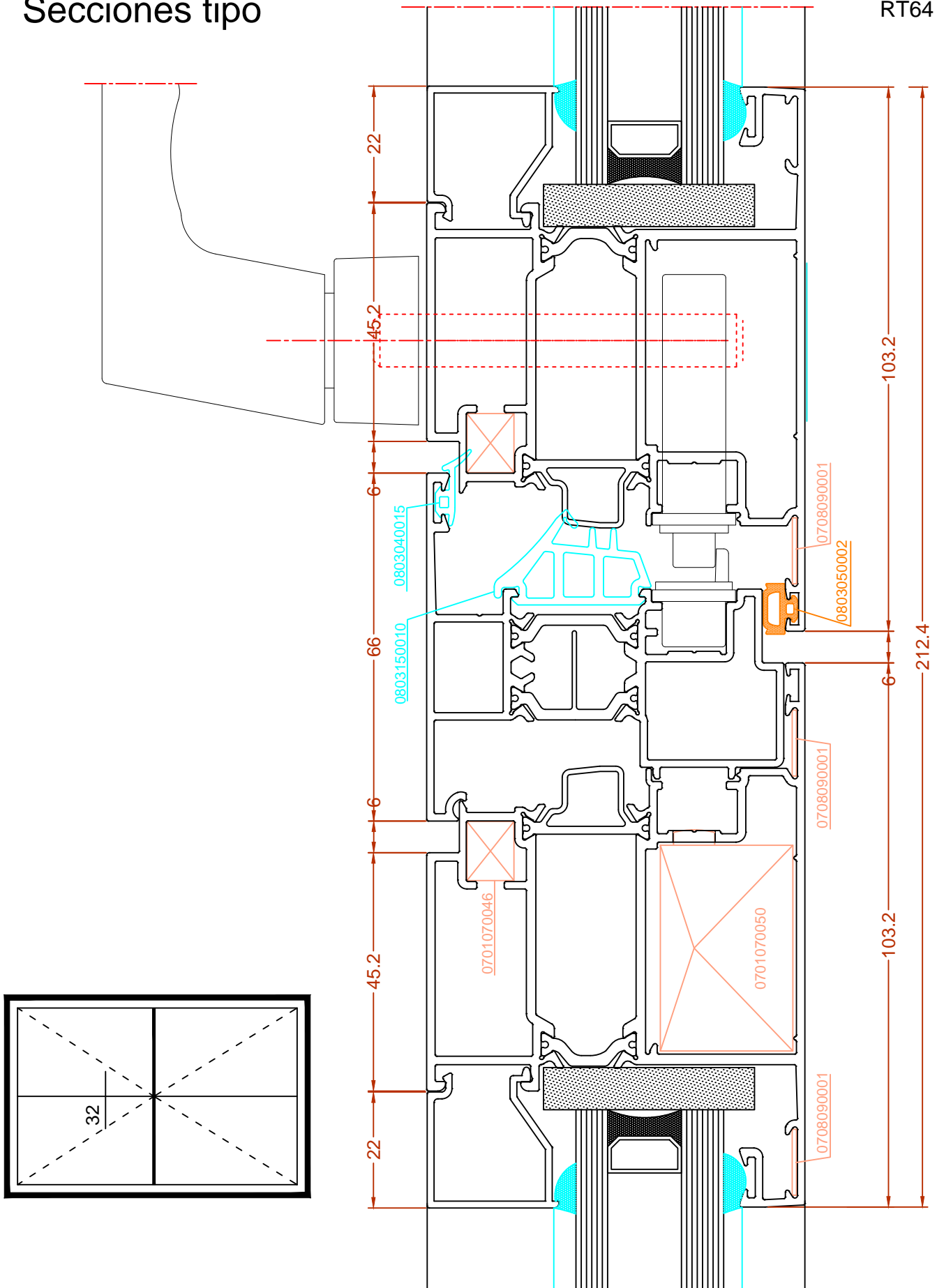

Secciones tipo

RT64 C16 - G16

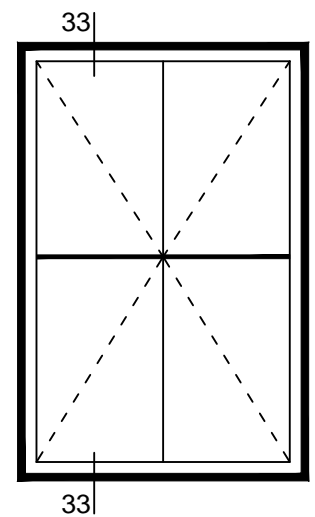
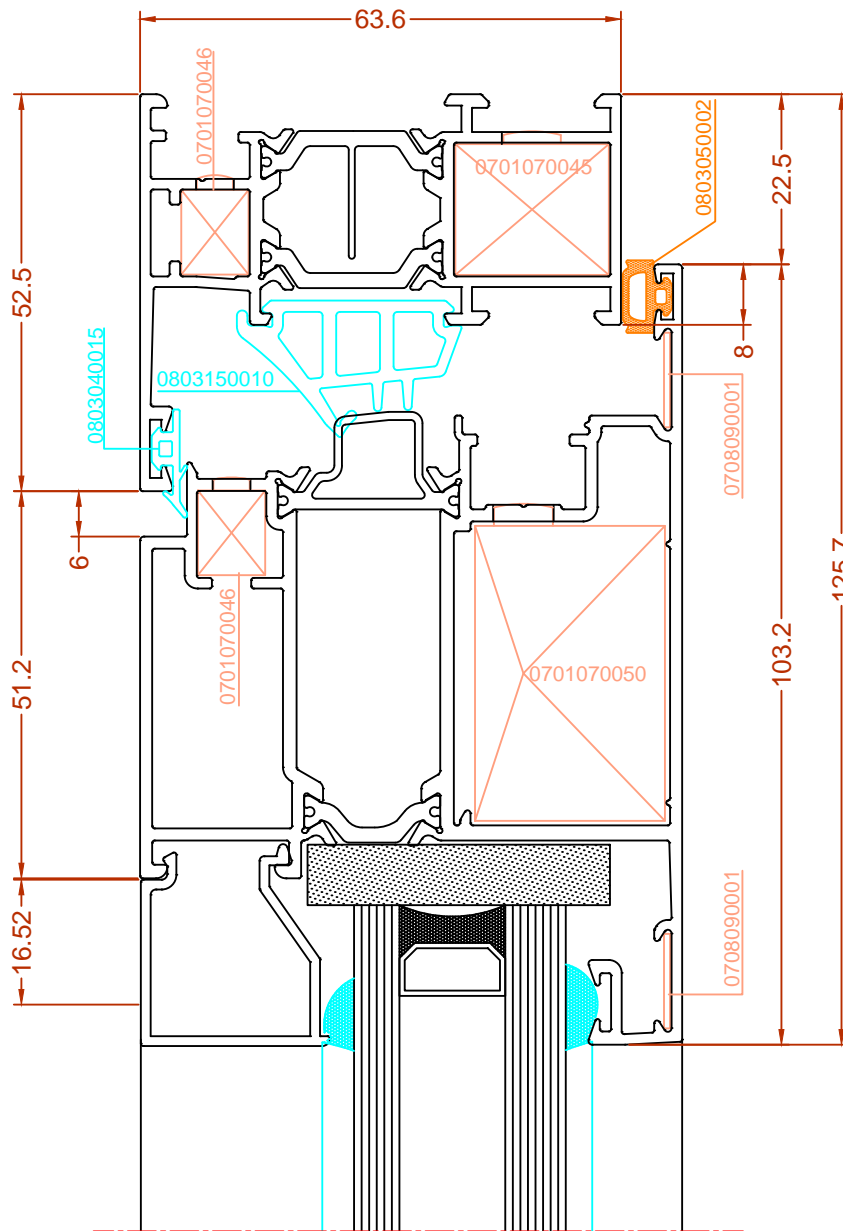

Secciones tipo

RT64 C16 - G17

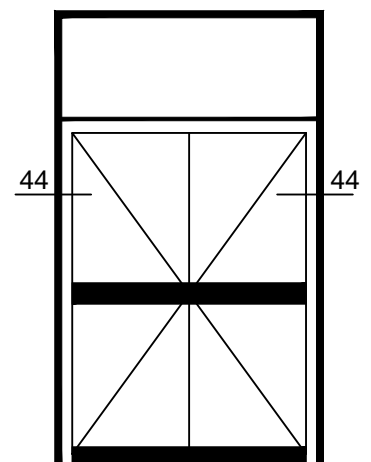
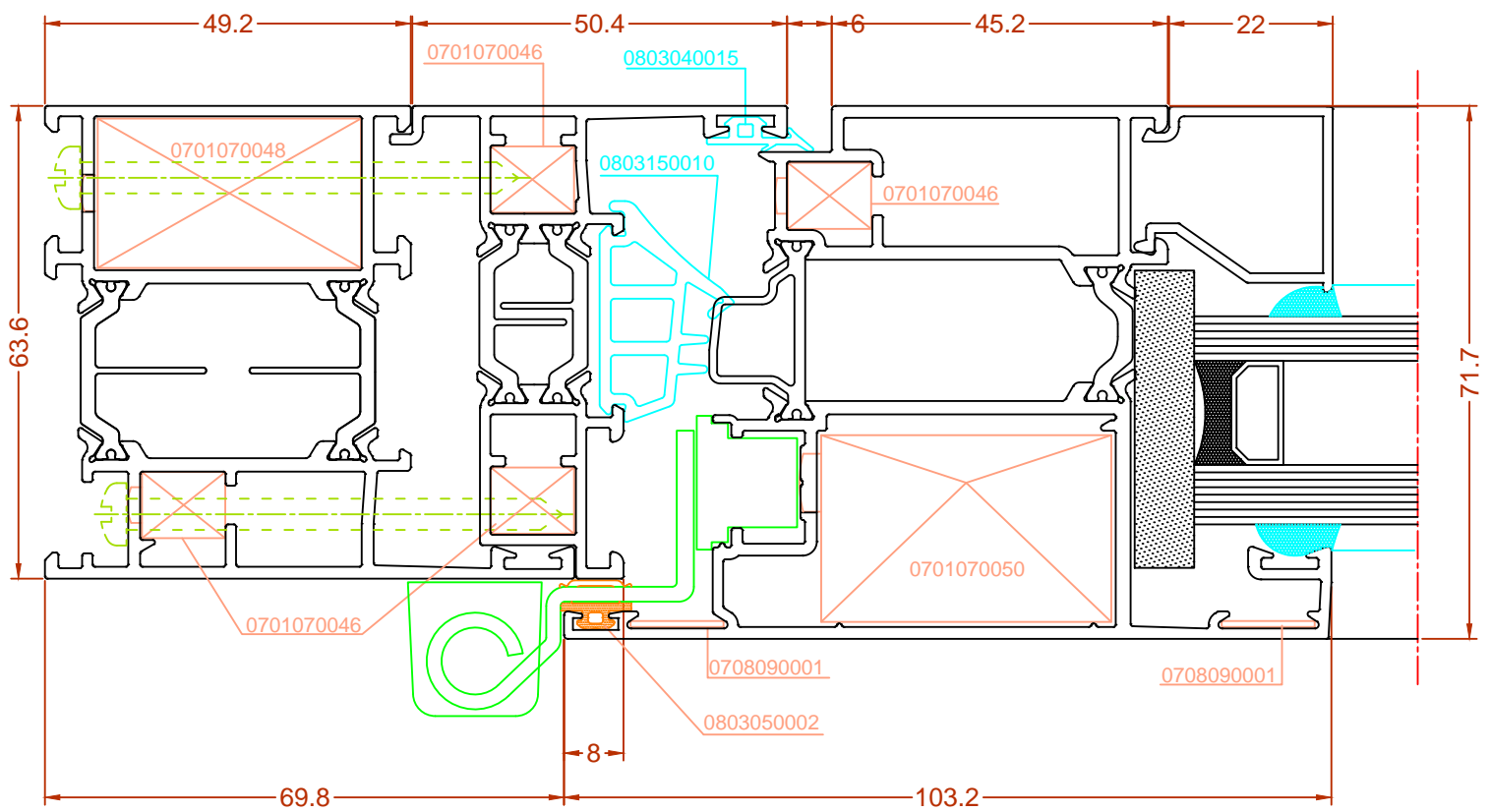

Secciones tipo

RT64 C16 - G18

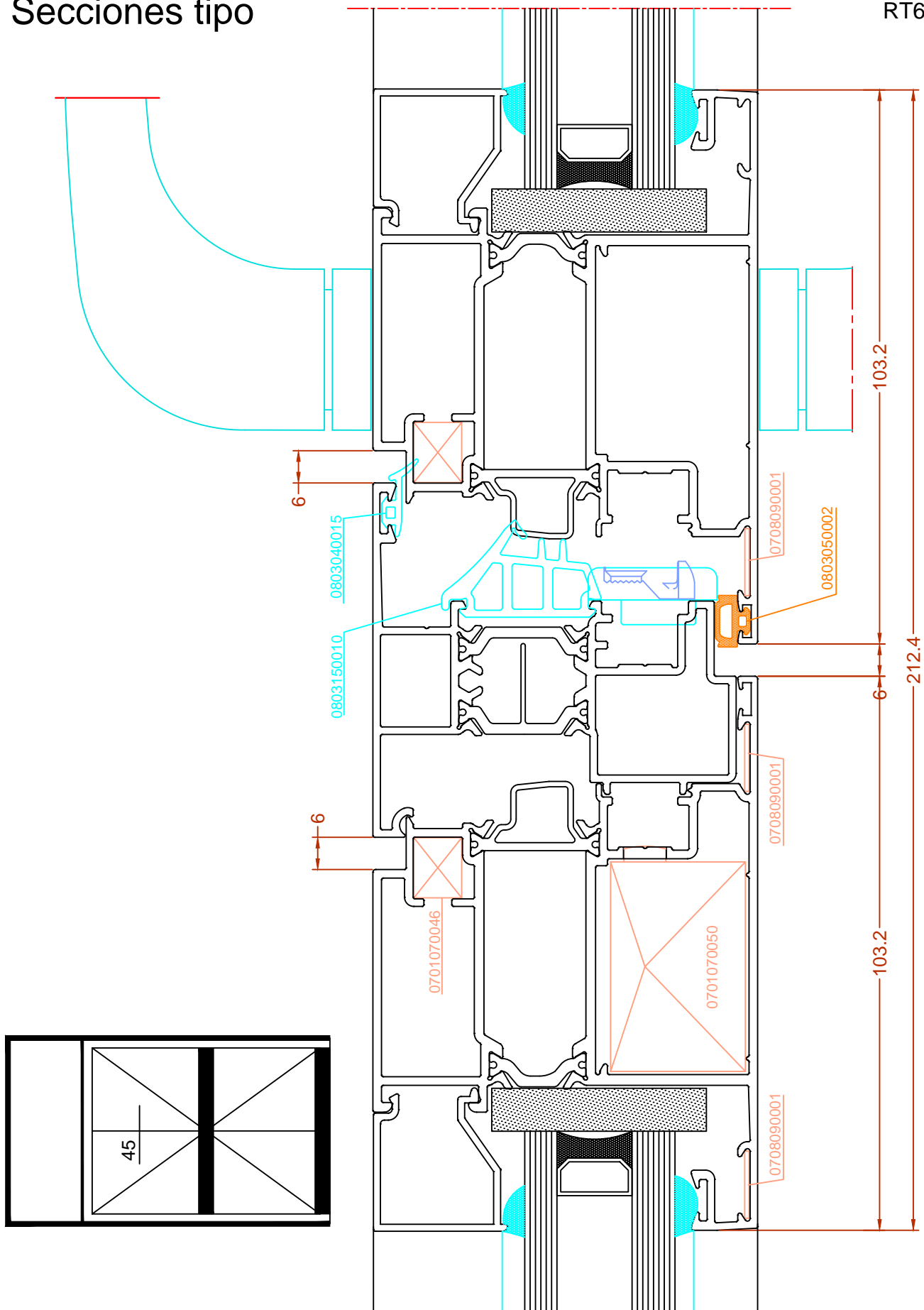

Secciones tipo

RT64 C16 - G19

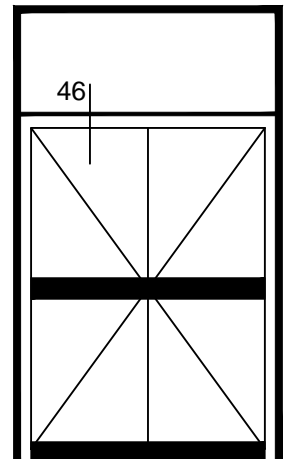
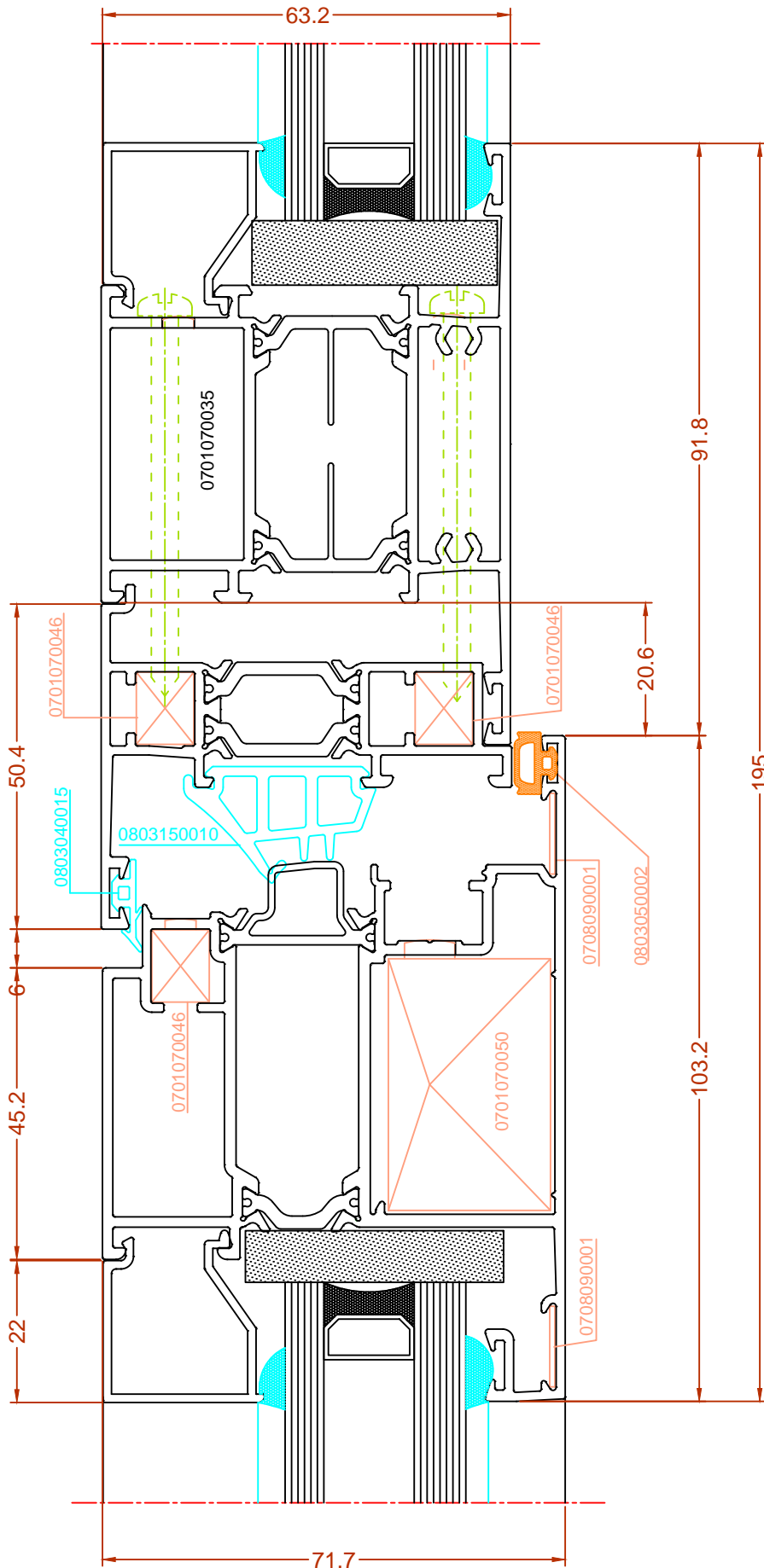

Secciones tipo

RT64 C16 - G20

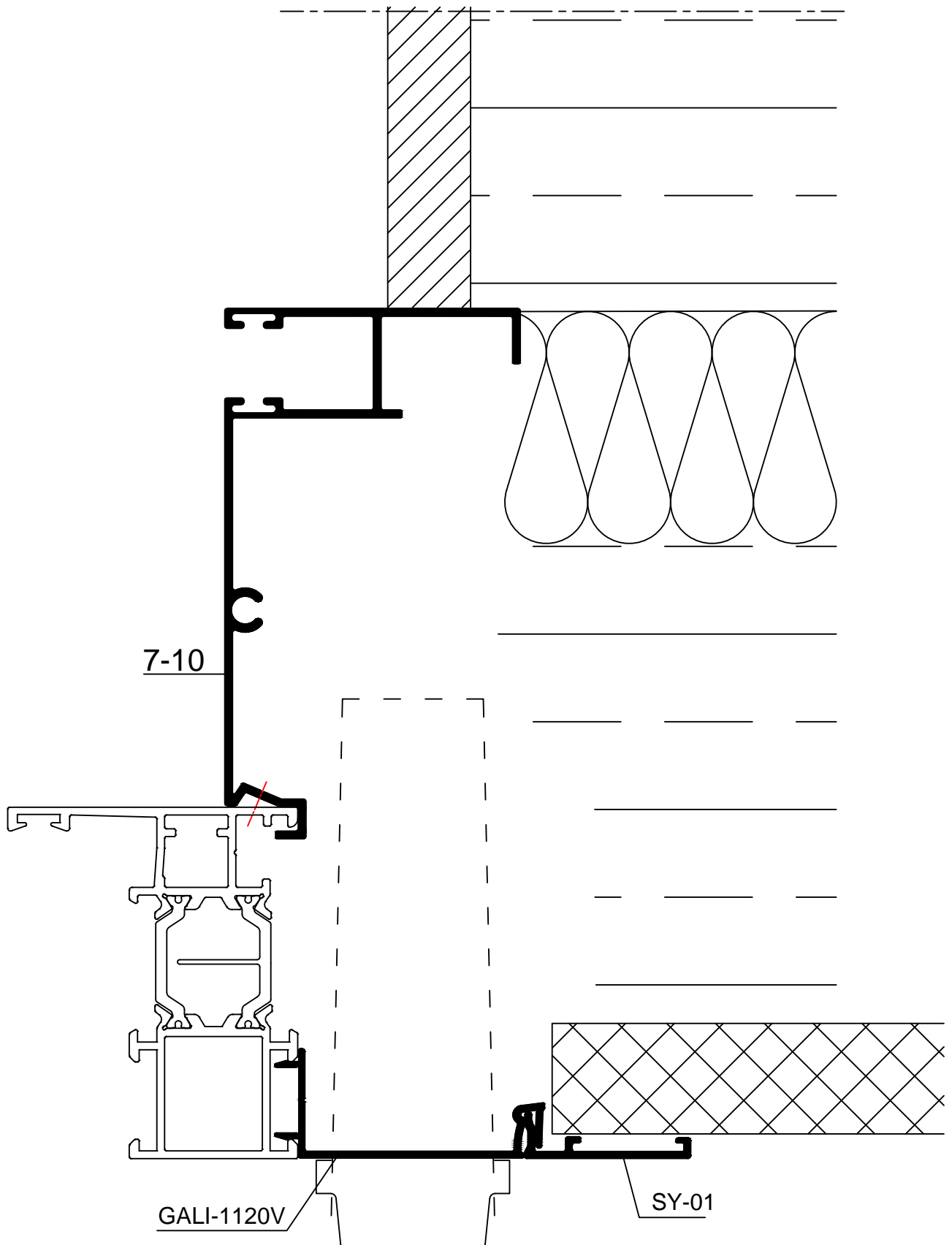

Secciones tipo

RT64 C16 - G21

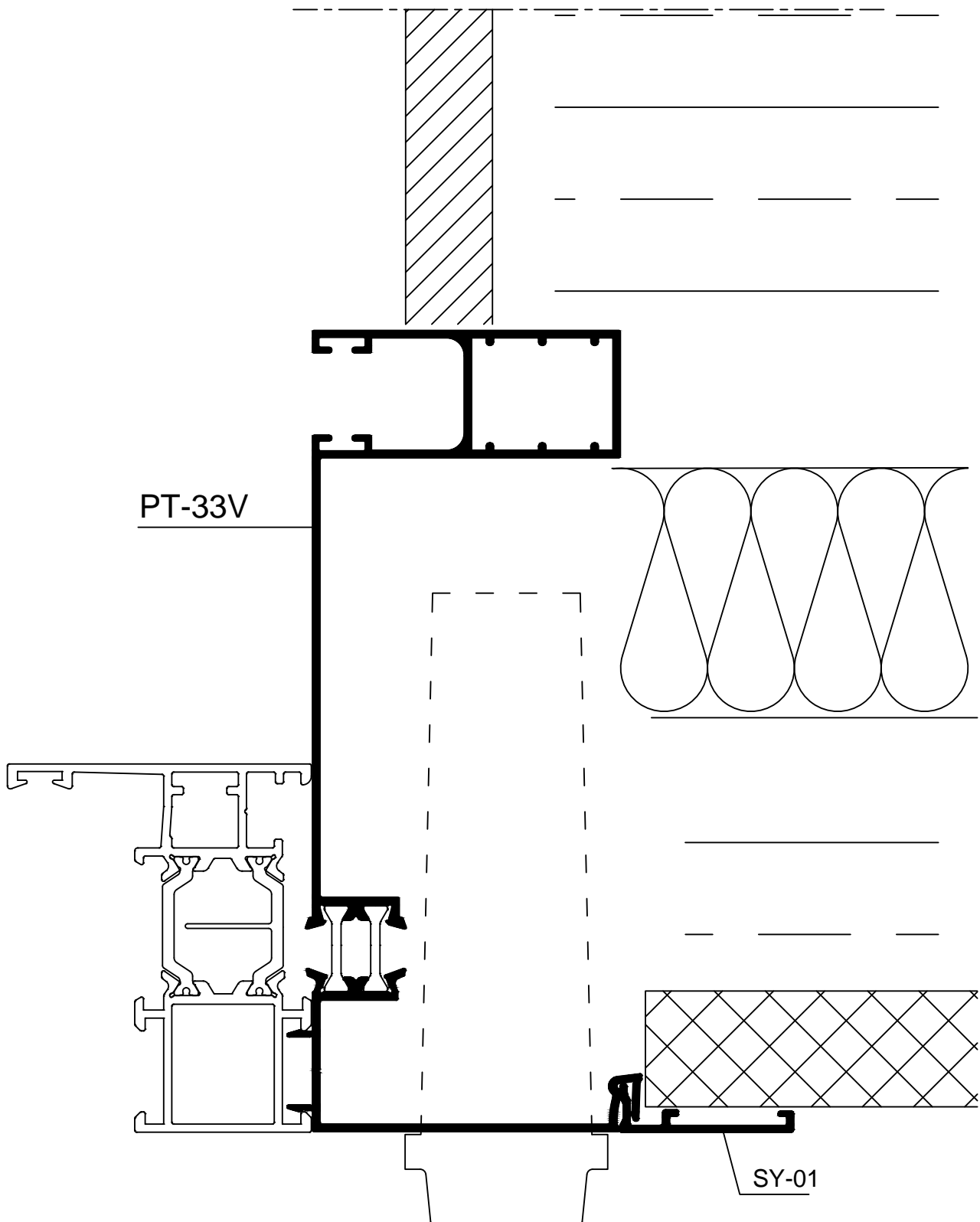

Secciones tipo

RT64 C16 - G22

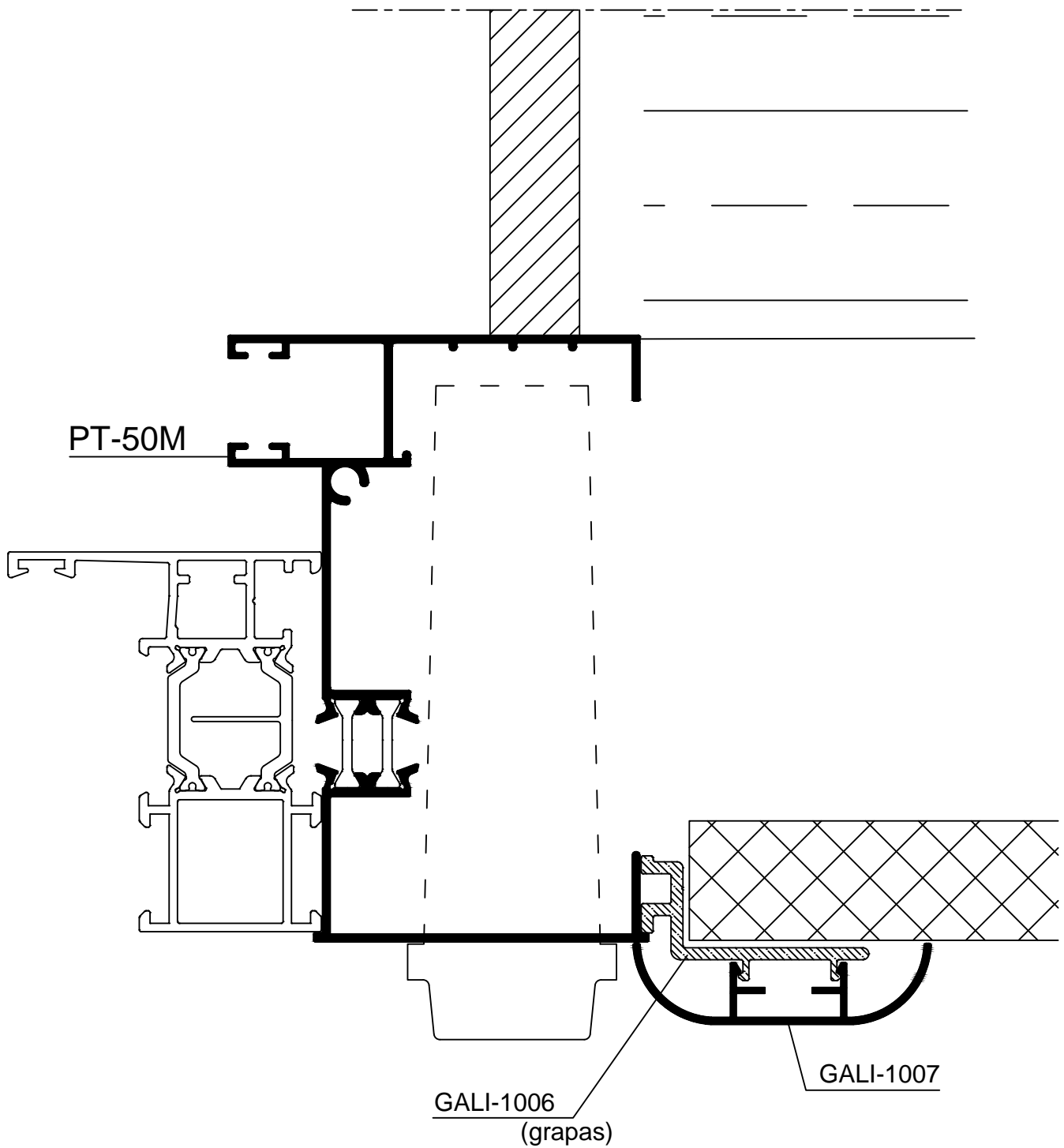

Secciones tipo

RT64 C16 - G23

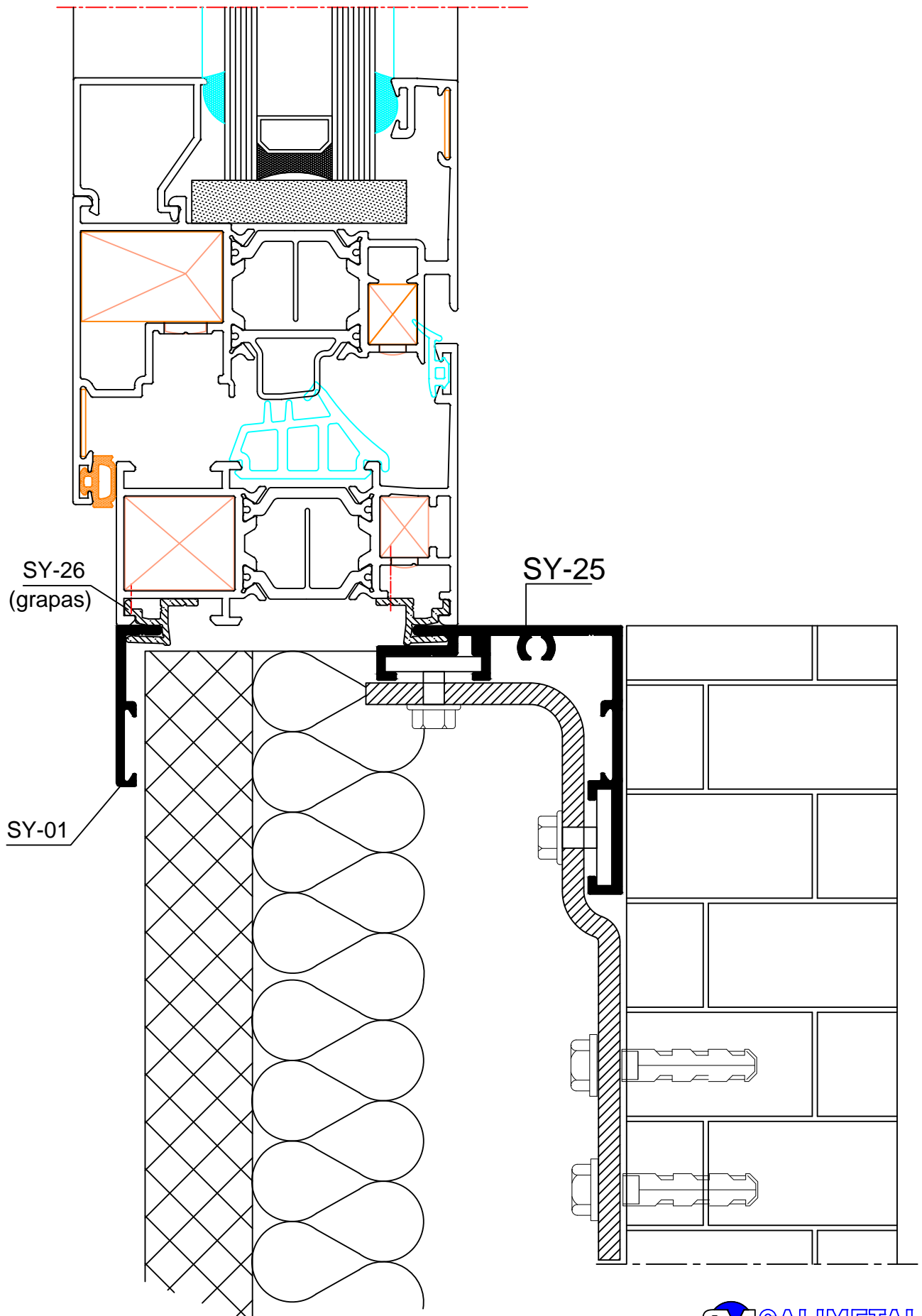

Secciones tipo

RT64 C16 - G24

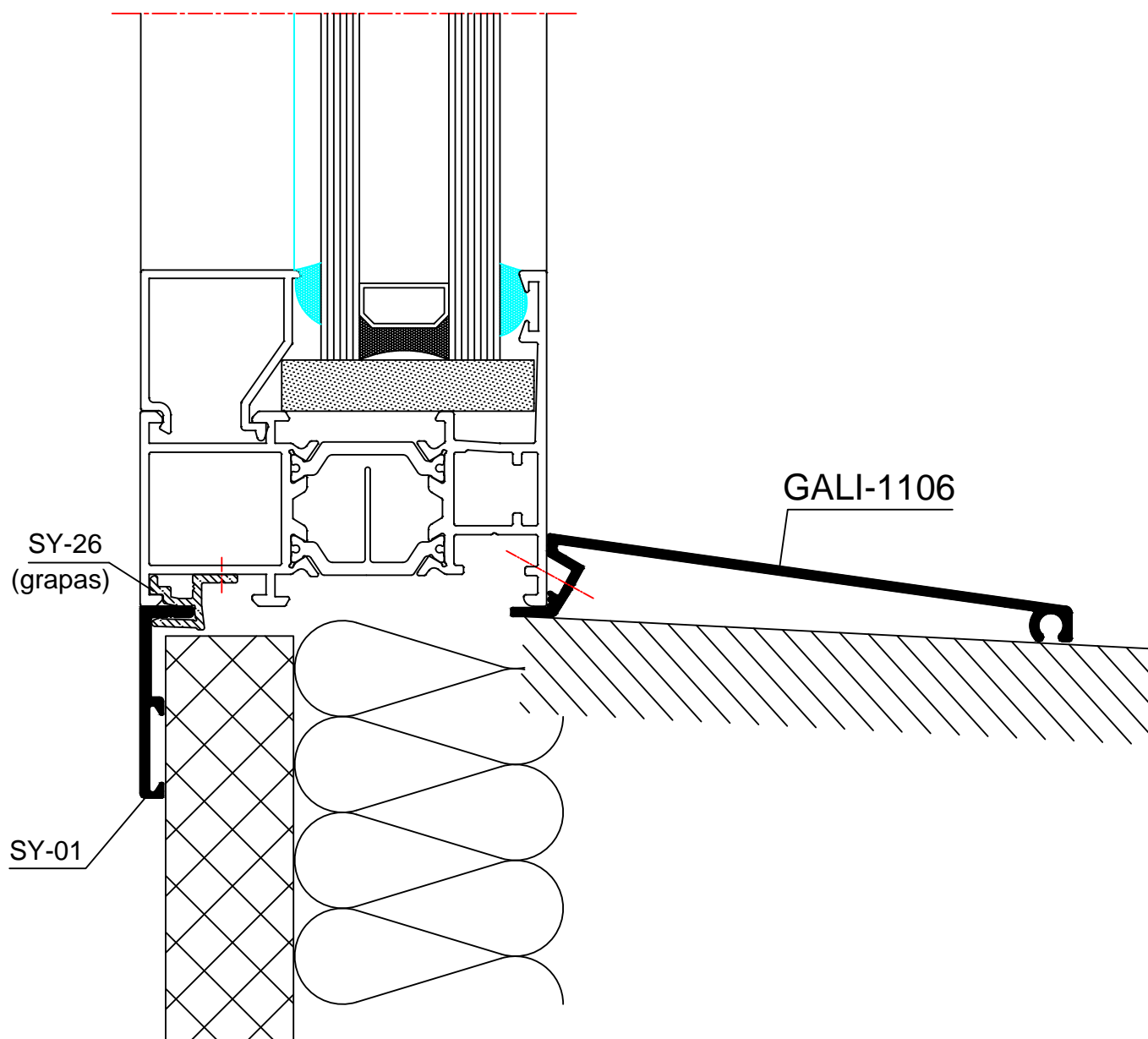

Secciones tipo

RT64 C16 - G25

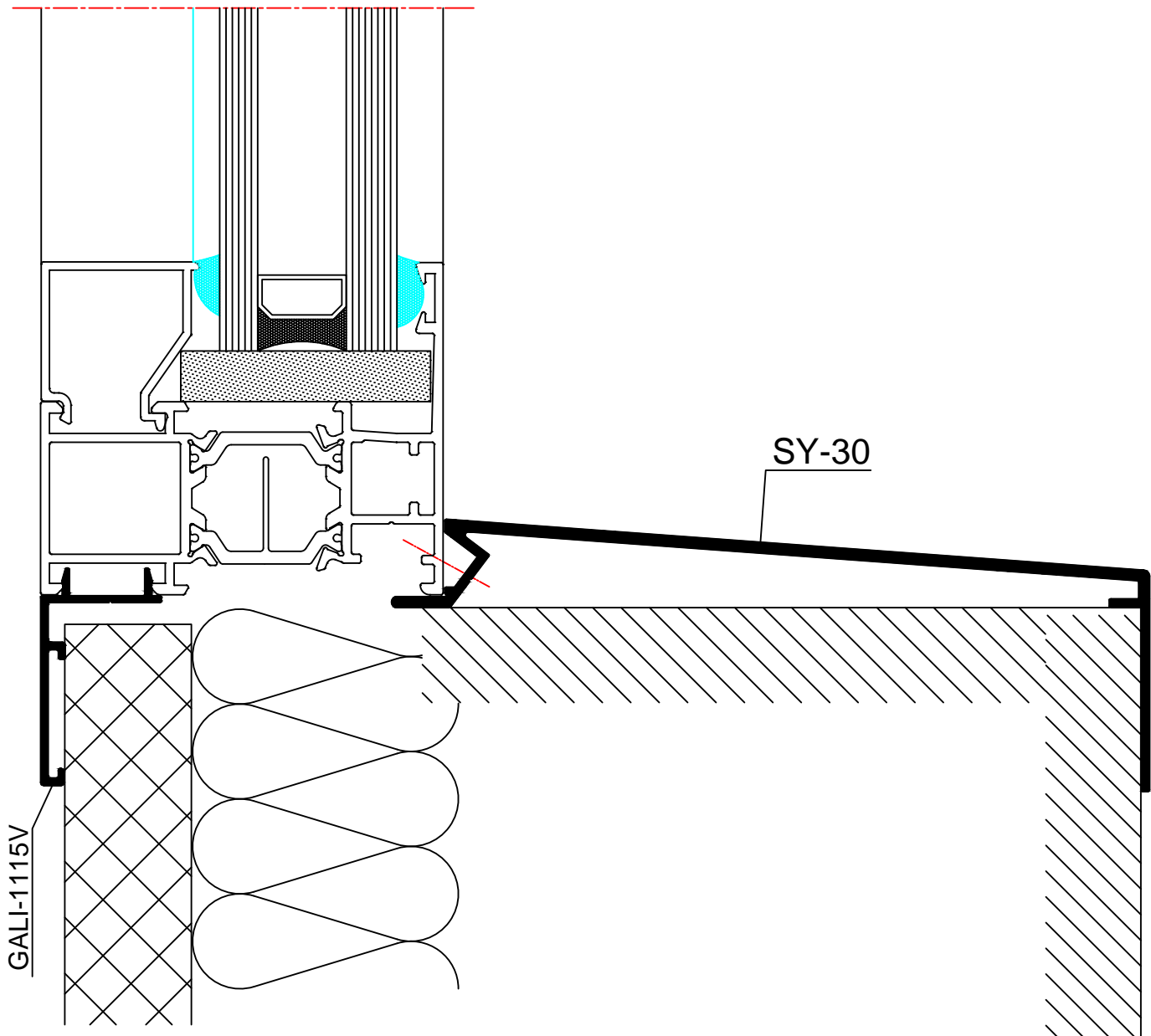

Hojas de corte

GUÍA

RT64_C16 - F1

Ventanas abrir interior

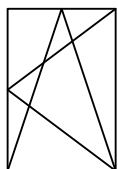

Hoja F-i1

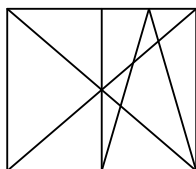

Hoja F-i2

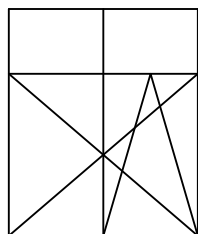

Hoja F-i3

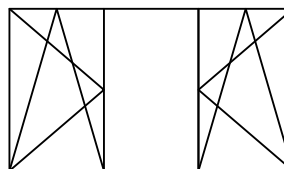

Hoja F-i4

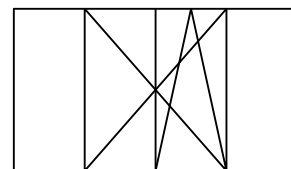

Hoja F-i5

Balconeras abrir int.

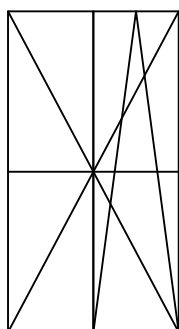

Hoja F-Bi1

Balconeras abrir ext.



Hoja F-Be1

Puertas entr. abrir int.

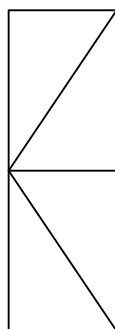

Hoja F-Pi1

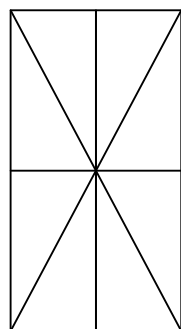

Hoja F-Pi2

Puertas entr. abrir ext.



Hoja F-Pe1

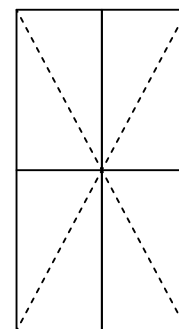





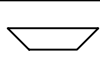

Hoja F-Pe2

Hojas de corte Ventana 1 hoja apertura interior

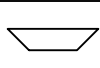
RT64_C16 - Fi1

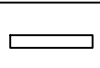

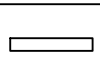

PERFILES

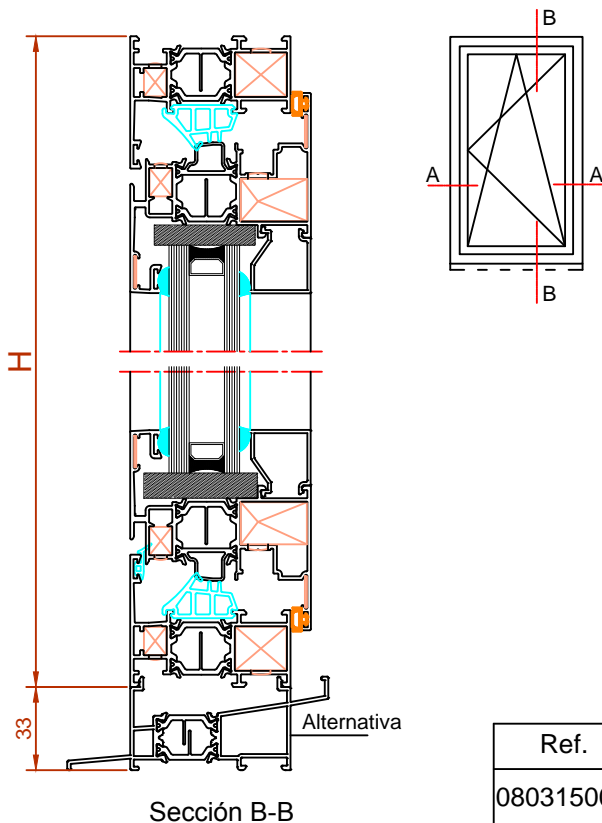
Croquis	Referencia	Corte	Medida	Cant.
	64-01		L	2
			H *	2
	64-102		L - 45	2
			H - 45 *	2
	Según vidrio		L-160	2
	S90-51E		H-204 *	2
	Alternativa *		L	1
	64-05			

* Medida sin condensador; caso de llevarlo reduce la altura 33 mm



Juntas

Ref.	Croquis	Cant.
0803150010		2xL+2xH
0803040015		L+2xH
0803050002		2xL+2xH
		2xL+2xH (Opcional bajo vidrio)

VIDRIOS

Ancho	Alto	Cant.
L-171	H-171 *	1

ACCESORIOS **

Ref.	Descripción	Cant.
1103170002	Tapa salida agua	2* (4)
0701070045	Escu. int. extru. marco	4
0701070049	Escua. int. extru. hoja	4
0701070046	Escuadras 11x9	8
0708090001	Escuadras alineami.	8

** Ver herraje en pag. H5

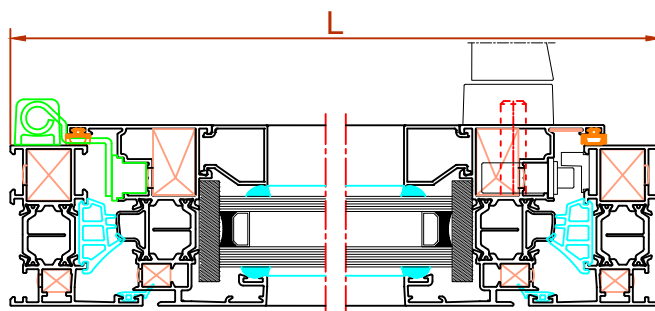



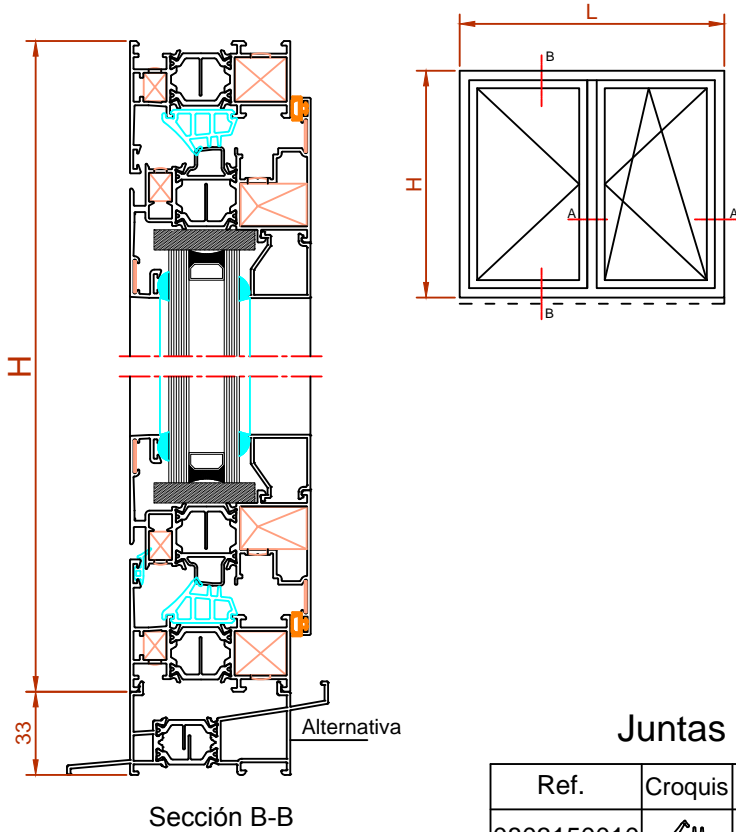

Hojas de corte Ventana 2 hojas apertura interior

RT64_C16 - Fi2













Sección B-B

Juntas

Ref.	Croquis	Cant.
0803150010		2xL+3xH
0803040015		L+3xH
0803050002		2xL+3xH
		2xL+4xH (Opcional bajo vidrio)

PERFILES

Croquis	Referencia	Corte	Medida	Cant.
	64-01		L	2
			H*	2
	64-102		L/2 - 25,5	4
			H - 45*	4
	64-103		H - 122*	1
	Según vidrio		L/2-140,5	4
	S90-51E		H-204*	4
	Alternativa * 64-05		L	1

* Medida sin condensador; caso de llevarlo reduce la altura 33 mm

VIDRIOS

Ancho	Alto	Cant.
L/2-152	H-171*	2

ACCESORIOS**

Ref.	Descripción	Cant.
0901330005	Juego tapa inversora	1
1103170002	Tapa salida agua	2* (4)
0701070045	Escua. int. extr. marco	4
0701070049	Escua. int. extru. hoja	8
0701070046	Escuadras 11x9	12
0708090001	Escuadras alineami.	16

** Ver herraje en pags. H5 y H6

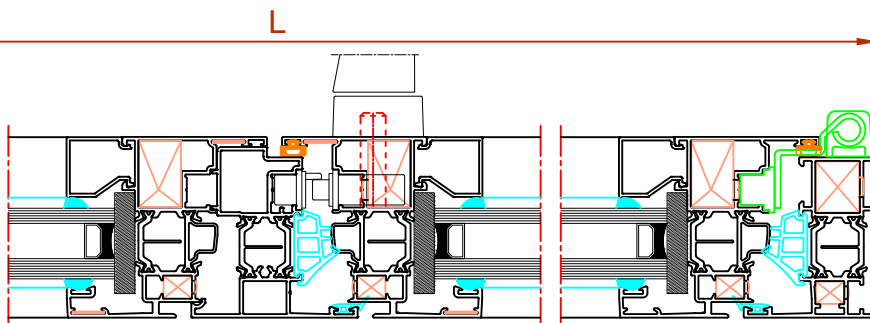







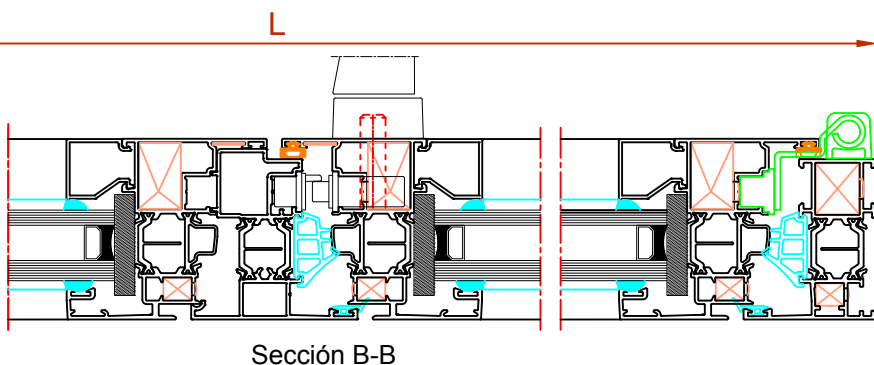
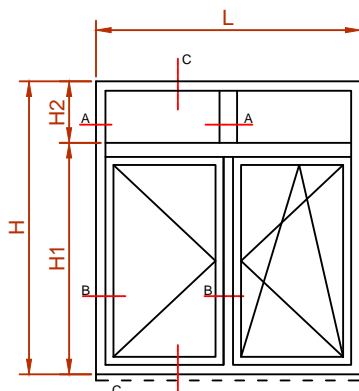
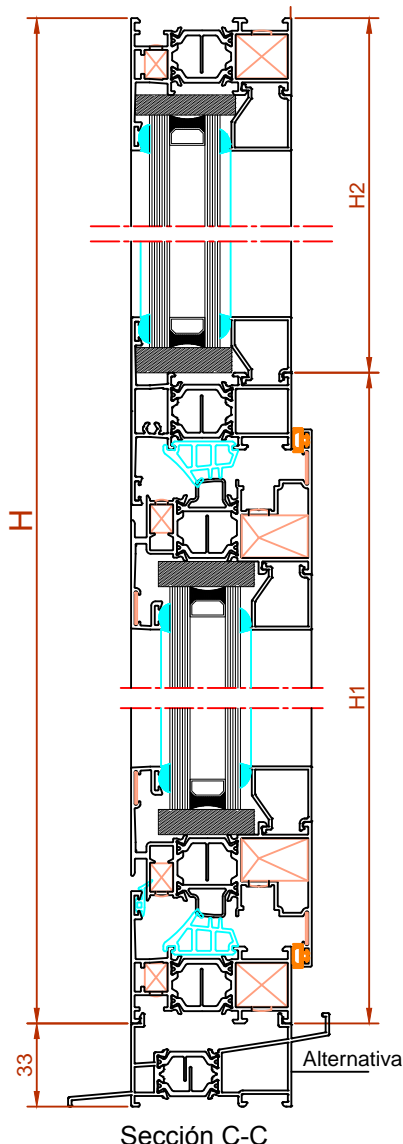









Sección A-A

Hojas de corte Ventana apertura interior

RT64_C16 - Fi3







PERFILES

Croquis	Referencia	Corte	Medida	Cant.
	64-01		L	2
			H*	2
	64-04		L - 51	1
	64-13		H2 - 20,5	1
	64-102		L/2 - 25,5	4
			H1 - 45*	4
	64-103		H1 - 122*	1
	Según vidrio		L/2-55	2
	S90-51E		H2-75	2
	Según vidrio		L/2-140,5	2
	S90-51E		H1-204*	2
	Alternativa *		L	1

* Medida sin condensador; caso de llevarlo reduce la altura 33 mm

Juntas

Ref.	Croquis	Cant.
0803150010		2xL+3xH1
0803040015		L+3xH1
0803050002		2xL+3xH1
		4xL+4xH (Opcional bajo vidrio)

VIDRIOS

Ancho	Alto	Cant.
L/2-76	H2-52	2
L/2-152	H1-171*	2

ACCESORIOS**

Ref.	Descripción	Cant.
0901330005	Juego tapa inversora	1
1103170002	Tapa salida agua	2* (4)
0701070045	Escua. int. extr. marco	4
0701070049	Escua. int. extru. hoja	8
0701070046	Escuadras 11x9	12
0708090001	Escuadras alineami.	16
0701070047	Tope travesaño 17	2
0701070035	Tope travesaño 36	2







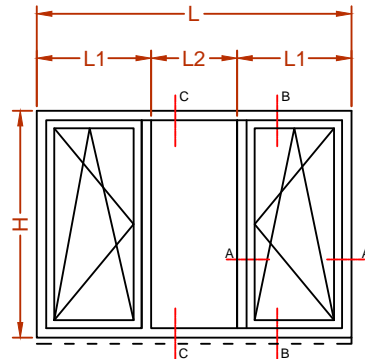
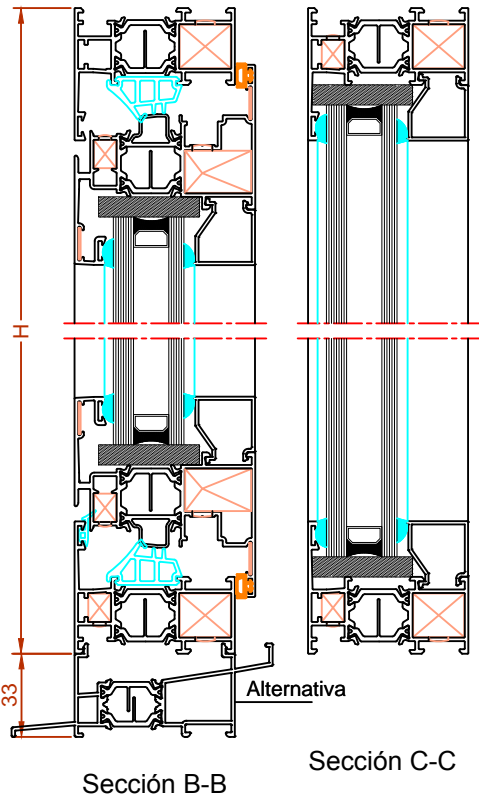





** Ver herraje en pag. H5 y H6

Hojas de corte Ventana apertura interior

RT64_C16 - Fi4







PERFILES

Croquis	Referencia	Corte	Medida	Cant.
	64-01		L	2
			H *	2
	64-04		H - 51 *	2
	64-102		L1 - 45	4
			H - 45 *	4
	Según vidrio		L1-160	4
	S90-51E		H-204*	4
	Según vidrio		L2	2
	S90-51E		H-105 *	2
	Alternativa *		L	1
	64-05		L	1

* Medida sin condensador; caso de llevarlo reduce la altura 33 mm

Juntas

Ref.	Croquis	Cant.
0803150010		4xL1+4xH
0803040015		2xL1+4xH
0803050002		4xL1+4xH
		2xL+6xH (Opcional bajo vidrio)

VIDRIOS

Ancho	Alto	Cant.
L1-171	H-171 *	2
L2-21	H-82 *	1

Para vidrios igual ancho $L1 = L/3 + 50$

ACCESORIOS**

Ref.	Descripción	Cant.
1103170002	Tapa salida agua	4* (6)
0701070045	Escu. int. extru. marco	4
0701070049	Escua. int. extru. hoja	8
0701070046	Escuadras 11x9	12
0708090001	Escuadras alineami.	16
0701070047	Tope travesaño 17	4

** Ver herraje en pag. H5

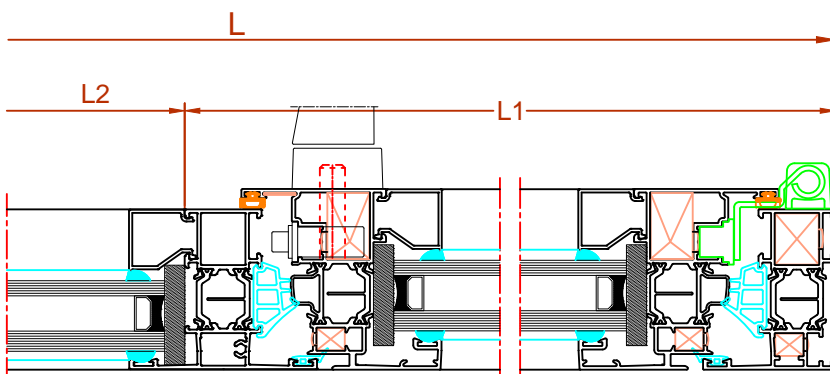







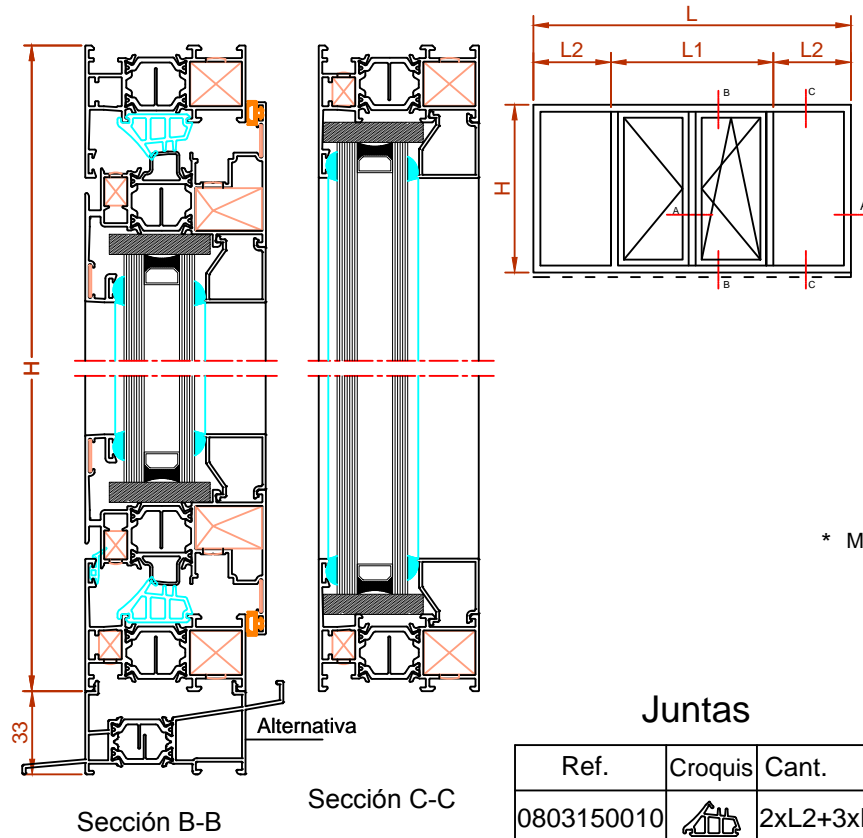







Sección A-A

Hojas de corte Ventana apertura interior

RT64_C16 - Fi5







PERFILES

Croquis	Referencia	Corte	Medida	Cant.
	64-01		L	2
			H *	2
	64-04		H - 51 *	2
	64-102		L1/2 - 25,5	4
			H - 45 *	4
	64-103		H - 122 *	1
	Según vidrio		L1/2-140,5	4
	S90-51E		H-204 *	4
	Según vidrio		L2-30,5	4
	S90-51E		H-105 *	4
	Alternativa *		L	1
	64-05		L	1

* Medida sin condensador; caso de llevarlo reduce la altura 33 mm

Juntas

Ref.	Croquis	Cant.
0803150010		2xL2+3xH
0803040015		L2+3xH
0803050002		2xL2+3xH
		2xL+8xH (Opcional bajo vidrio)

VIDRIOS

Ancho	Alto	Cant.
L1/2-152	H-171 *	2
L2 - 52	H-82 *	2

Para vidrios igual ancho L1= L/2+100

ACCESORIOS **

Ref.	Descripción	Cant.
0901330005	Juego tapa inversora	1
1103170002	Tapa salida agua	2* (4)
0701070045	Escua. int. extr. marco	4
0701070049	Escua. int. extru. hoja	8
0701070046	Escuadras 11x9	12
0708090001	Escuadras alineami.	16
0701070047	Tope travesaño 17	4











** Ver herraje en pags. H5 y H6

Sección A-A

Hojas de corte Balconera 2 hojas apertura interior

RT64_C16 - F-Bi1



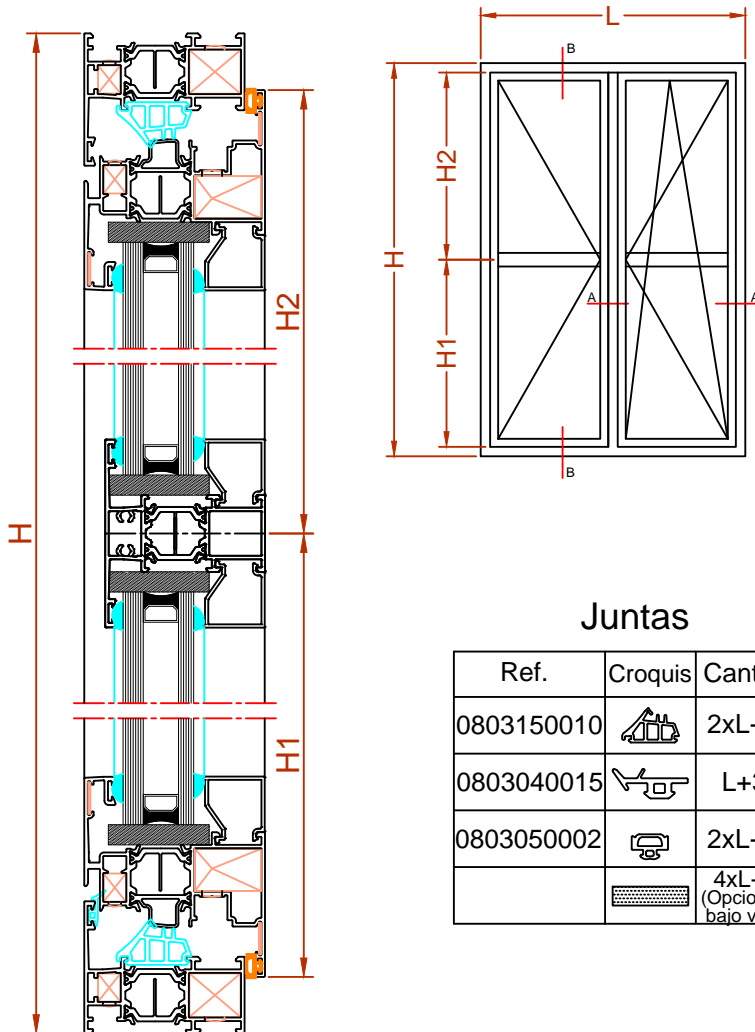

PERFILES

Croquis	Referencia	Corte	Medida	Cant.
	64-01		L	2
			H	2
	64-102		L/2 - 25,5	4
			H - 45	4
	64-04		L/2-130,5	2
	64-103		H - 122	1
	Según vidrio S90-51E		L/2-140,5	8
			H1-117	4
			H2-117	4



Sección B-B

Juntas

Ref.	Croquis	Cant.
0803150010		2xL+3xH
0803040015		L+3xH
0803050002		2xL+3xH
		4xL+4xH (Opcional bajo vidrio)

VIDRIOS

Ancho	Alto	Cant.
L/2-152	H1-89	2
L/2-152	H2-89	2

ACCESORIOS**

Ref.	Descripción	Cant.
0901330005	Juego tapa inversora	1
1103170002	Tapa salida agua	2 (4)
0701070045	Escua. int. extr. marco	4
0701070049	Escua. int. extru. hoja	8
0701070046	Escuadras 11x9	12
0708090001	Escuadras alineami.	16
0701070047	Tope travesaño 17	2

** Ver herraje en pags. H5 y H6

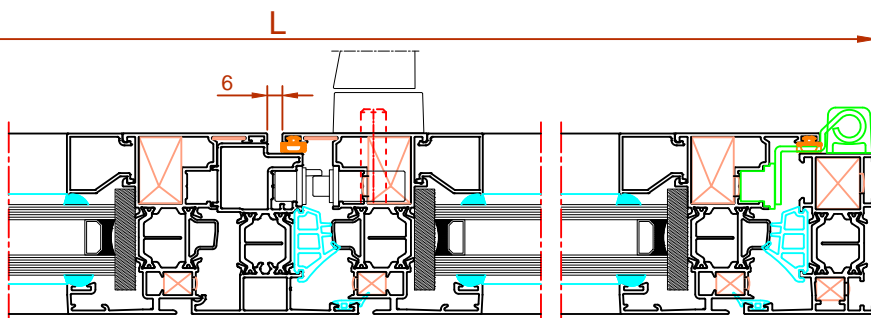









Sección A-A

Hojas de corte Balconera apertura exterior

RT64 C16 - F-Be1



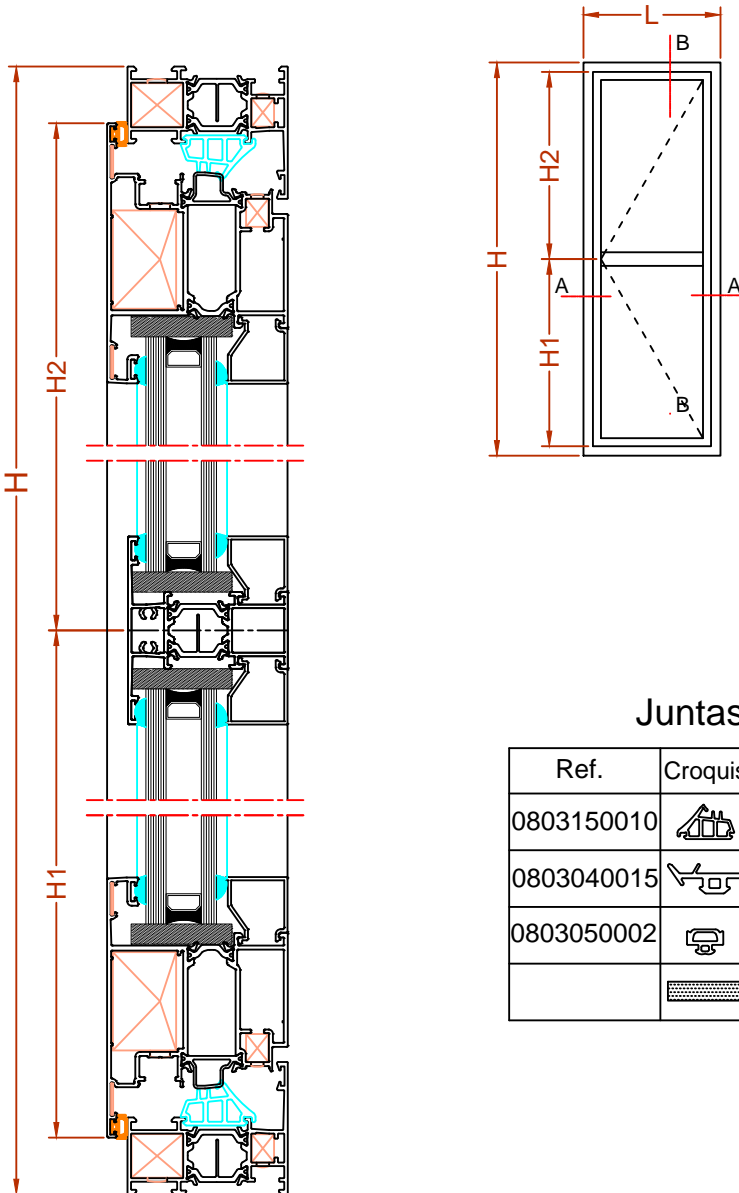

PERFILES

Croquis	Referencia	Corte	Medida	Cant.
	64-01		L	2
			H	2
	64-111		L - 45	2
			H - 45	2
	64-04		L - 197,5	1
	Según vidrio		L-207,5	4
	S90-51E		H1 - 141	2
			H2 - 141	2



Sección B-B

Juntas

Ref.	Croquis	Cant.
0803150010		2xL+2xH
0803040015		L+2xH
0803050002		2xL+2xH
		4xL+2xH (Opcional bajo vidrio)

VIDRIOS

Ancho	Alto	Cant.
L-215	H1 - 109	1
L-215	H2 - 109	1

ACCESORIOS**

Ref.	Descripción	Cant.
1103170002	Tapa salida agua	2
0701070045	Escua. int. extr. marco	4
0701070050	Escua. int. extru. hoja	4
0701070046	Escuadras 11x9	8
0708090001	Escuadras alineami.	8
0701070047	Tope travesaño 17	2

** Ver herraje en pag. H7

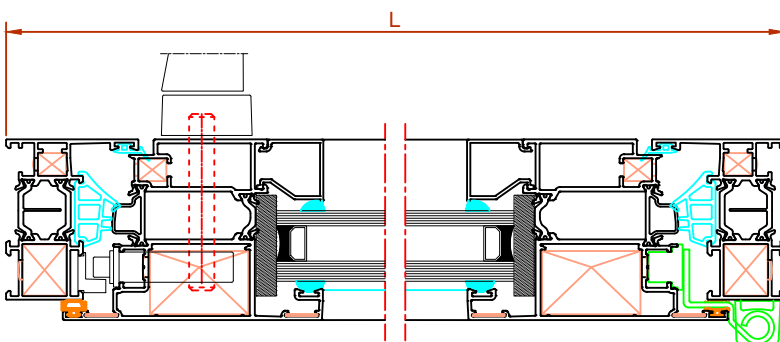

Sección A-A

Hojas de corte Puerta entrada apertura interior

RT64_C16 F-Pi1

PERFILES

Croquis	Referencia	Corte	Medida	Cant.
	64-14		L H+60	1 2 (1+1)
	64-115		L - 82,5 H - 48	1 2 (1+1)
	64-16		L-234	2
	Según vidrio S90-51E		L-244	5
			H1-180	4
			H2-163	4

VIDRIOS

Ancho	Alto	Cant.
L-251	H1-153	1
L-251	H2-131	1

Juntas

Ref.	Croquis	Cant.
0803150010		L+2xH
0803040015		L+2xH
0803050002		L+2xH
		4xL+2xH (Opcional bajo vidrio)

ACCESORIOS

Ref.	Descripción	Cant.
	Cerradura 3 puntos	1
	Cerradero central	1
	Cerradero sup/inf.	2
	Bombillo doble 30x70	1
	Manilla P.E. doble	1
	Bisagra practicable	*
0701070048	Escu. int. extru. marco	2
0701070050	Escua. int. extru. hoja	2
0701070046	Escuadras 11x9	4
0708090001	Escuadras alineami.	4

* H < 1.600.- Cant 3
H > 1.600 > 2200.- Cant 4
H > 2.200.- Cant 5

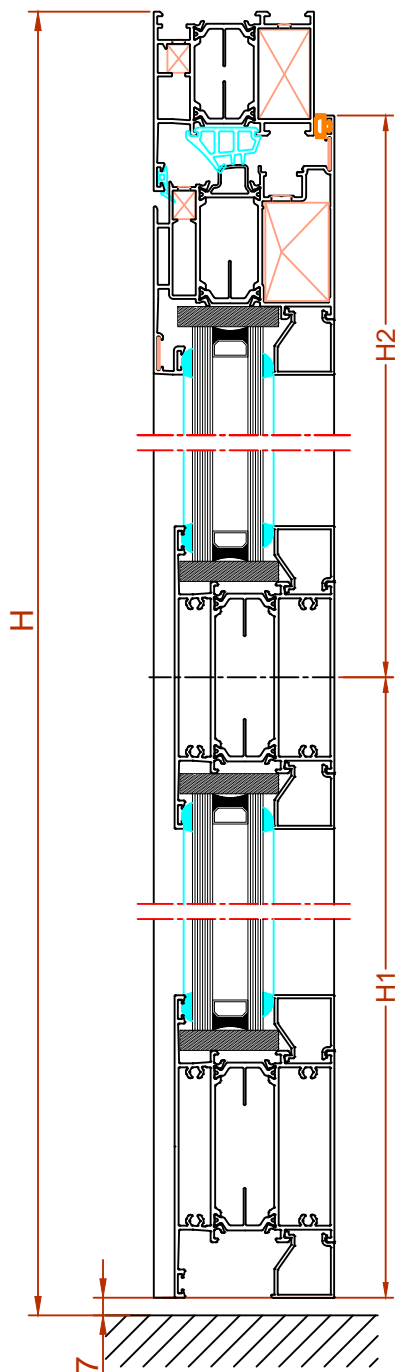

Sección B-B

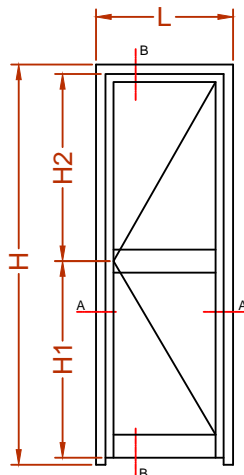



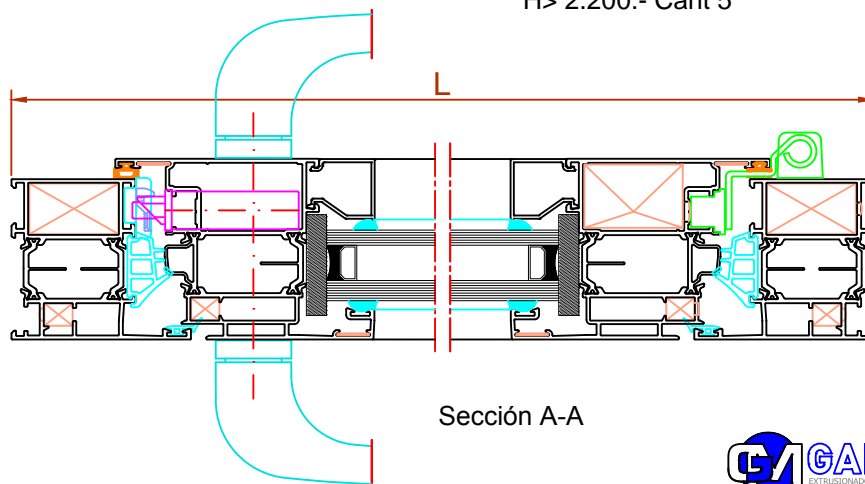









Sección A-A



Hojas de corte Puerta entrada apertura interior

RT64_C16 - F-Pi2





PERFILES

Croquis	Referencia	Corte	Medida	Cant.
	64-14		L	1
			H+60	2 (1+1)
	64-115		L/2 - 44,5	2
			H - 48	4 (2+2)
	64-16		L/2-196	4
	64-103		H - 86,5	1
	Según vidrio S90-51E		L/2-206	10
			H1-180	4
			H2-163	4

VIDRIOS

Ancho	Alto	Cant.
L/2-213	H1-153	2
L/2-213	H2-131	2

Juntas

Ref.	Croquis	Cant.
0803150010		L+3xH
0803040015		L+3xH
0803050002		L+3xH
		4xL+4xH (Opcional bajo vidrio)

ACCESORIOS

Ref.	Descripción	Cant.
	Cerradura 3 puntos	1
	Cerradero central	1
	Cerradero sup/inf.	2
	Bombillo doble 30x70	1
	Manilla P.E. doble	1
	Juego pasador prac.	1
	Bisagra practicable	*
0901330005	Juego tapa inversora	1
0701070048	Escu. int. extru. marco	2
0701070050	Escua. int. extru. hoja	4
0701070046	Escuadras 11x9	6
0708090001	Escuadras alineami.	8

* H < 1.600.- Cant 6
 H > 1.600 > 2200.- Cant 8
 H > 2.200.- Cant 10

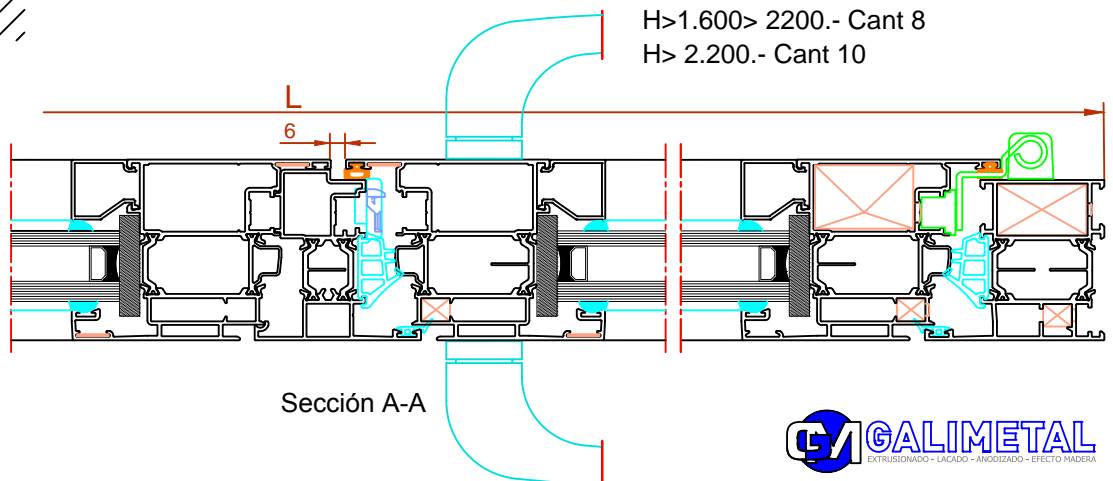
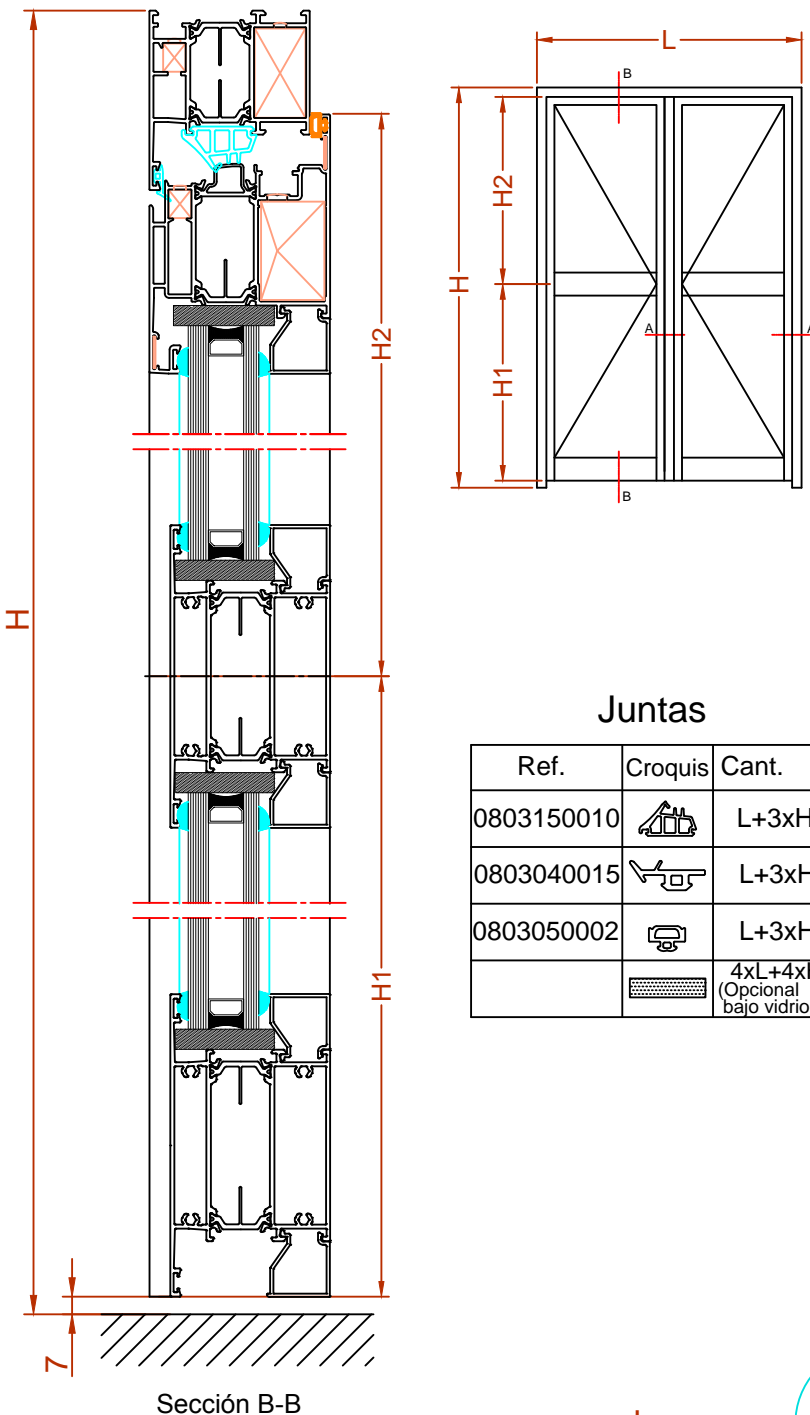

Hojas de corte Puerta entrada apertura exterior



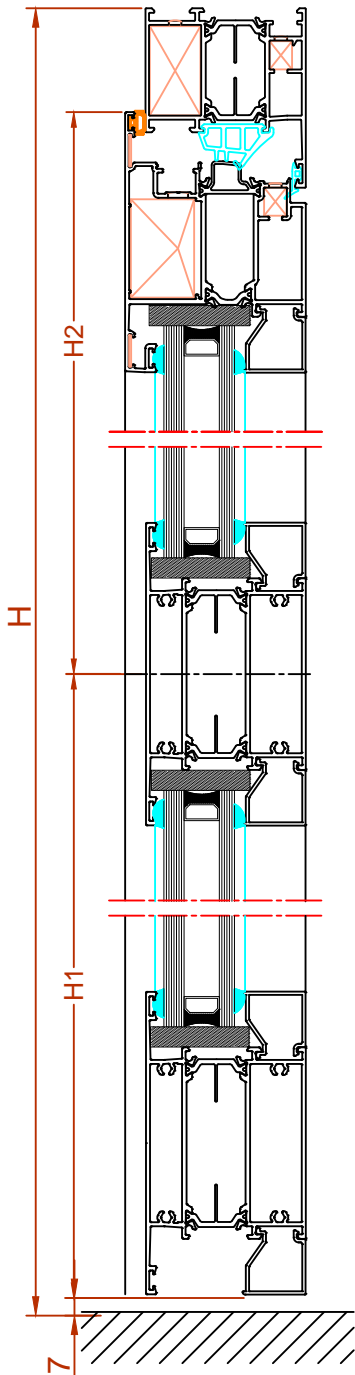



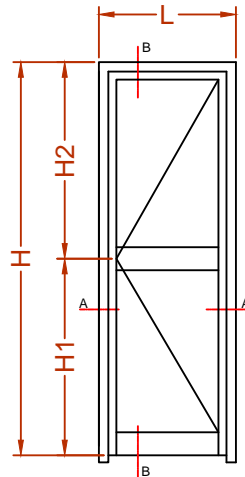





RT64 C16 - F-Pe1



Sección B-B







PERFILES

Croquis	Referencia	Corte	Medida	Cant.
	64-14		L	1
	64-111		H+60	2 (1+1)
			L - 82,5	1
	64-16		H - 48	2 (1+1)
			L-235	2
	Según vidrio S90-51B		L-245	5
			H1-180	2
			H2-164	2

VIDRIOS

Ancho	Alto	Cant.
L-253	H1-153	2
L-253	H2-131	2

Juntas

Ref.	Croquis	Cant.
0803150010		L+2xH
0803040015		L+2xH
0803050002		L+2xH
		4xL+2xH (Opcional bajo vidrio)

ACCESORIOS

Ref.	Descripción	Cant.
	Cerradura 3 puntos	1
	Cerradero central	1
	Cerradero sup/inf.	2
	Bombillo doble 30x70	1
	Manilla P.E. doble	1
	Bisagra practicable	*
0701070048	Escu. int. extru. marco	2
0701070050	Escua. int. extru. hoja	2
0701070046	Escuadras 11x9	4
0708090001	Escuadras alineami.	4

* H < 1.600.- Cant 3

H > 1.600 > 2200.- Cant 4

H > 2.200.- Cant 5

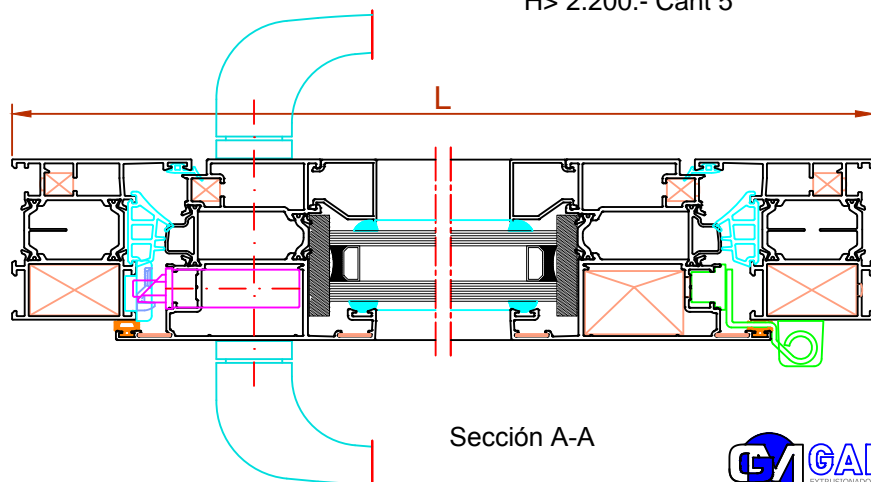













Sección A-A

Hojas de corte Puerta entrada apertura exterior

RT64_C16 - F-Pe2





PERFILES

Croquis	Referencia	Corte	Medida	Cant.
	64-14		L	1
			H+60	2 (1+1)
	64-111		L/2 - 44,5	2
			H - 48	4 (2+2)
	64-16		L/2-197	4
	64-103		H - 86,5	1
	Según vidrio S90-51E		L/2-206	10
			H1-180	4
			H2-163	4

VIDRIOS

Ancho	Alto	Cant.
L/2-215	H1-153	2
L/2-215	H2-132	2

Juntas

Ref.	Croquis	Cant.
0803150010		L+3xH
0803040015		L+3xH
0803050002		L+3xH
		4xL+4xH (Opcional bajo vidrio)

ACCESORIOS

Ref.	Descripción	Cant.
	Cerradura 3 puntos	1
	Cerradero central	1
	Cerradero sup/inf.	2
	Bombillo doble 30x70	1
	Manilla P.E. doble	1
	Juego pasador prac.	1
	Bisagra practicable	*
0901330005	Juego tapa inversora	1
0701070048	Escu. int. extru. marco	2
0701070050	Escua. int. extru. hoja	4
0701070046	Escuadras 11x9	6
0708090001	Escuadras alineami.	8

* H < 1.600.- Cant 6
 H > 1.600 > 2200.- Cant 8
 H > 2.200.- Cant 10

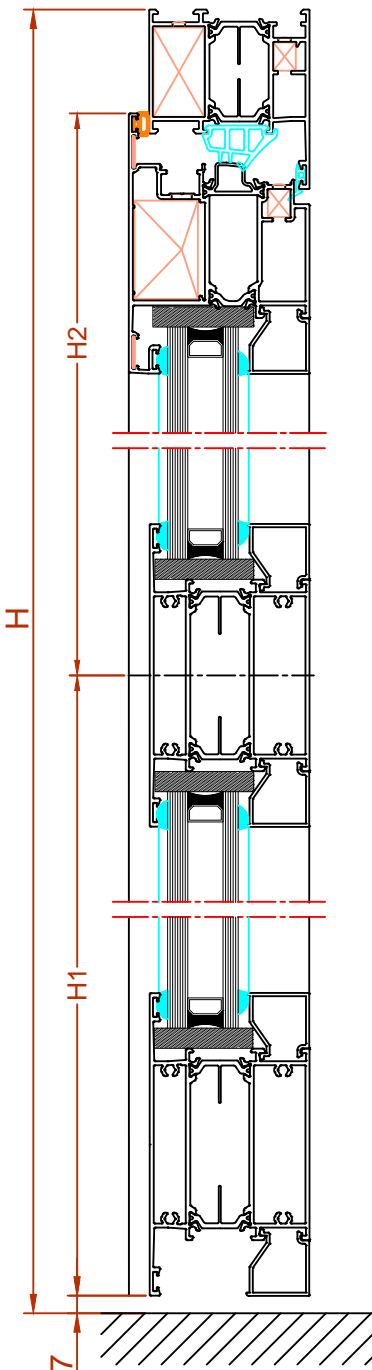

Sección B-B

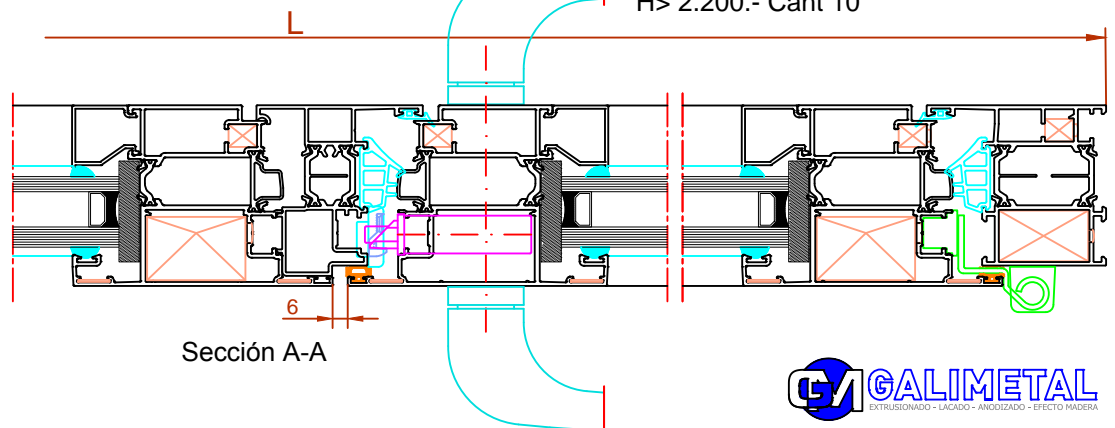
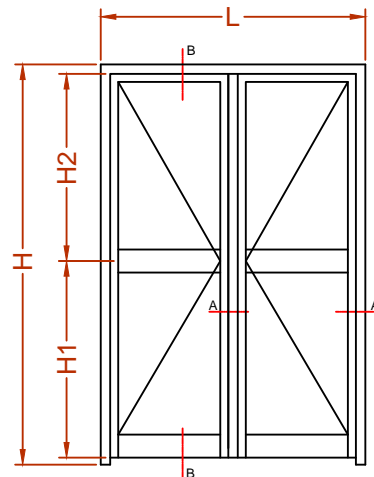

Sección A-A

Fabricación

RT64 C16 - H1

1.- CORTE PERFILES

Se cortaran los perfiles de marco y hoja a 45° en ambos extremos, respetando dimensiones y descuentos a aplicar según el modelo a fabricar. Los perfiles inversor y travesaño se cortan a 90°.

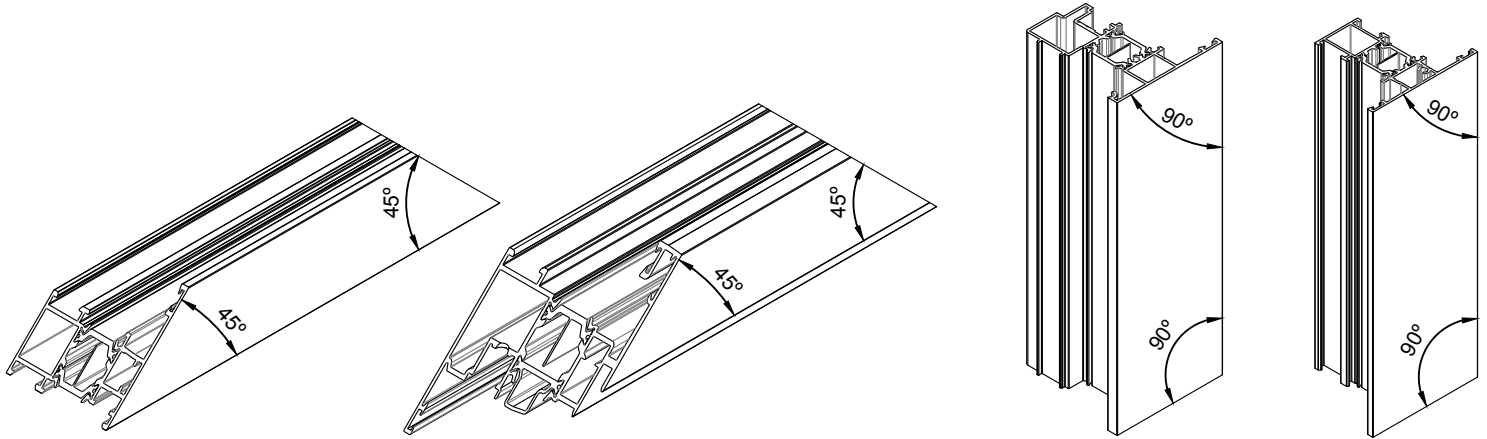

2.- TROQUELADO PERFILES Ver detalle troquel en pag. H7

Marco

Escuadras

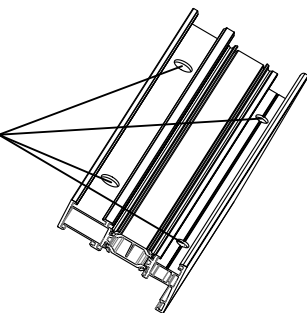

Troquelar las dos cabezas.
(escuadra de extrusión)

Salida aguas

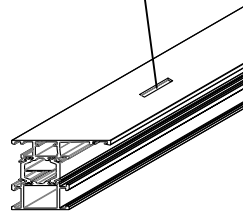

Troquelar barra inferior

Hacer en el perfil inferior

- Para $L < 600$ mm hacer 1 desagüe situado al centro.
- Para $600 < L < 1300$ mm hacer 2 desagües situados 150 mm de cada extremo.
- Para $L > 1300$ mm hacer 4 desagües según esquema

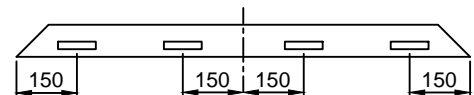

Hoja

Escuadras

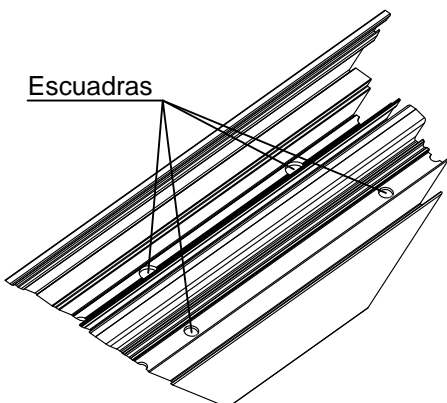

Troquelar las dos cabezas (Esc. extrusión)

Travesaño

Tope unión travesaño

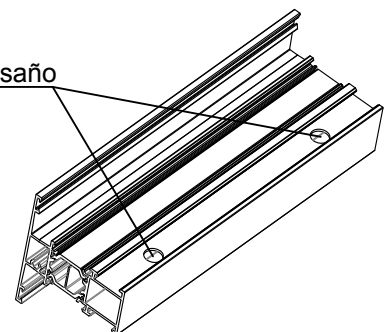

Troquelar las dos cabezas.

Fabricación

RT64 C16 - H2

3.- OTROS MECANIZADOS

Marco

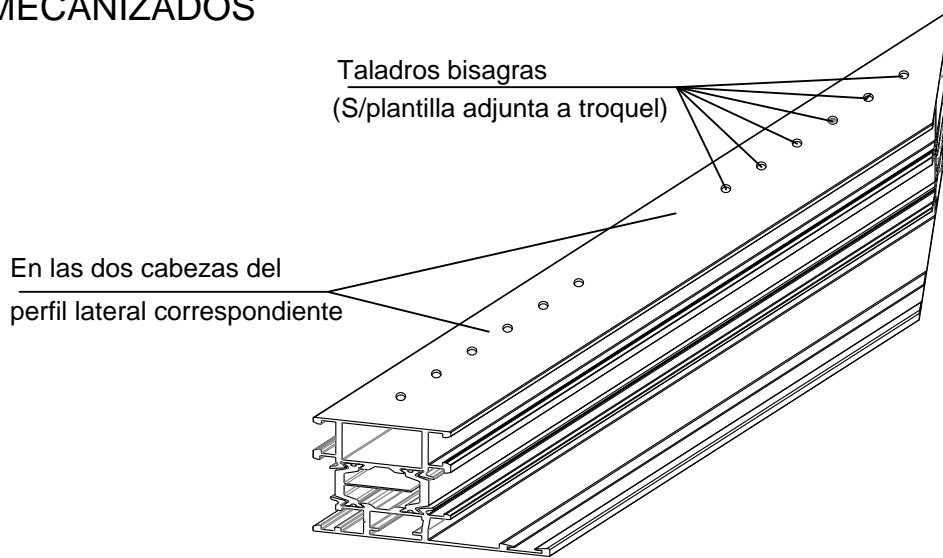

Hoja

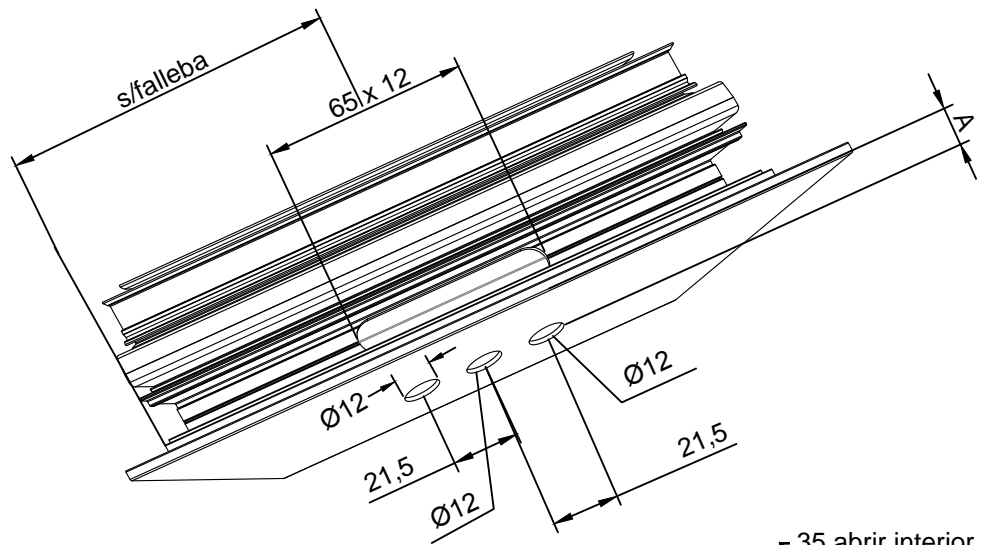

Abrir falleba y taladros manilla
con cremonera o plantilla

Cota A = { 35 abrir interior
55 abrir exterior

Travesaño

Retestar las dos cabezas
con grupo fresas

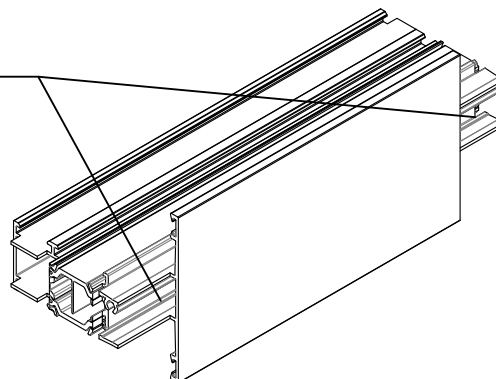

Fabricación

RT64 C16 - H3

3.- MONTAJE ESCUADRAS

Se aplicará sellante sobre las caras del corte inglete para garantizar la estanqueidad del mismo.
A continuación se montan todas las escuadras necesarias según catalogo y se aprietan las escuadras de bloqueo.

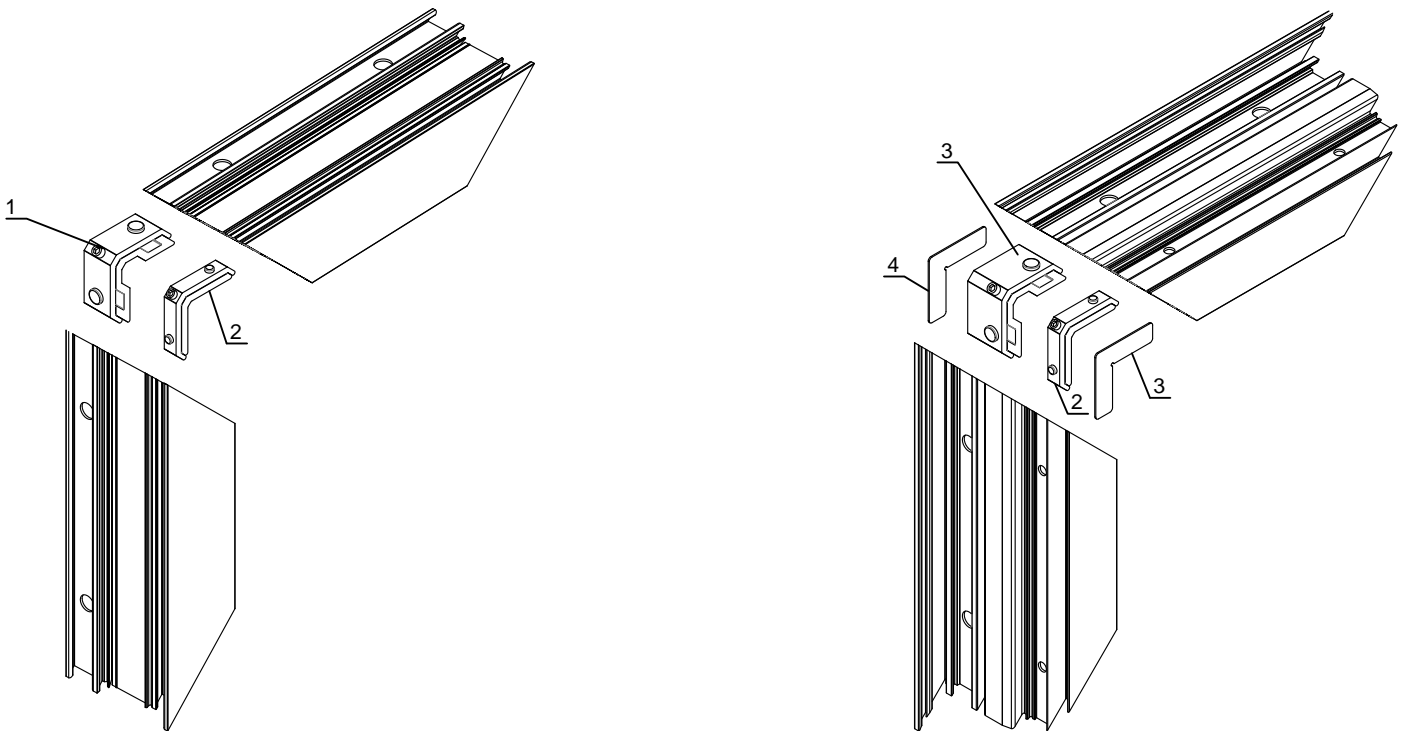

1-2-3: Escuadras bloqueo extrusión
4: Escuadras alineamiento

4.- Colocación juntas

Colocar juntas según catalogo: Las centrales de estanqueidad y la acople térmico (en su caso), se colocaran perimetrales continuas en los 4 lados; la exterior se recomienda no colocar en la parte superior. La interior no se colocará en el perfil hoja coincidente con el inversor.

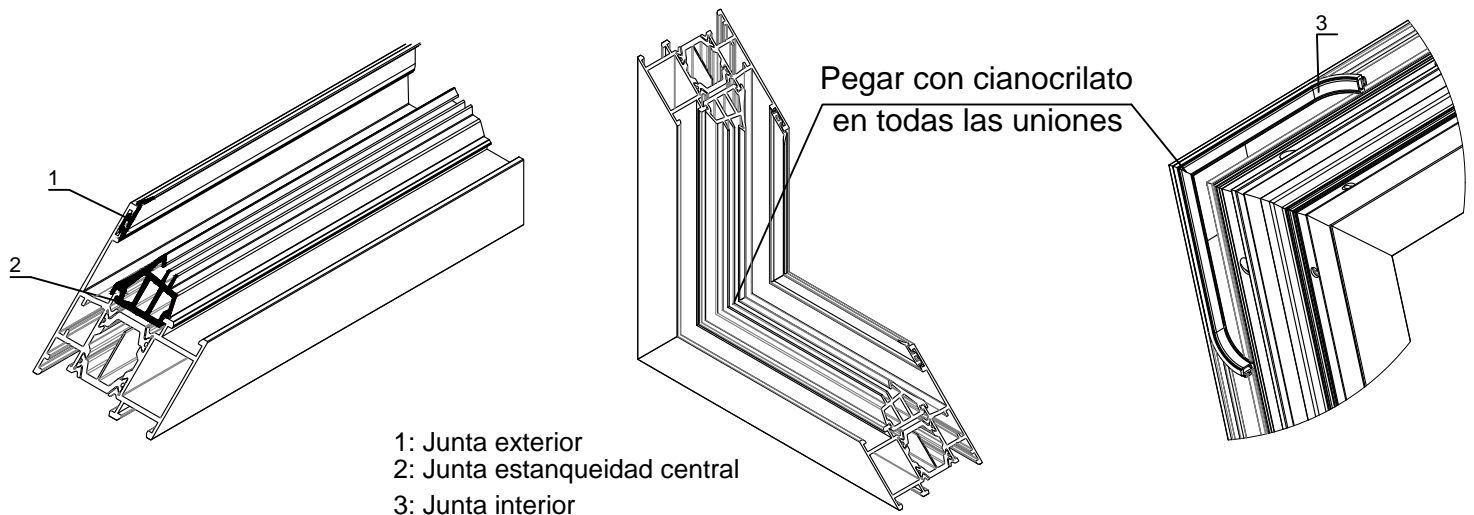

1: Junta exterior
2: Junta estanqueidad central
3: Junta interior

Fabricación

RT64 C16 - H4

5.- MONTAJE INVERSOR

- 1.- Aplicar sellante entre perfil inversor y tapa; atornillar tapa con tornillo de 4,2x25 DIN 7971
- 2.- Aplicar sellante en la pestaña exterior del perfil inversor en contacto con el perfil hoja
- 3.- Atornillar perfil inversor a perfil hoja con tornillos de 4,2x32 cada 300-400 mm

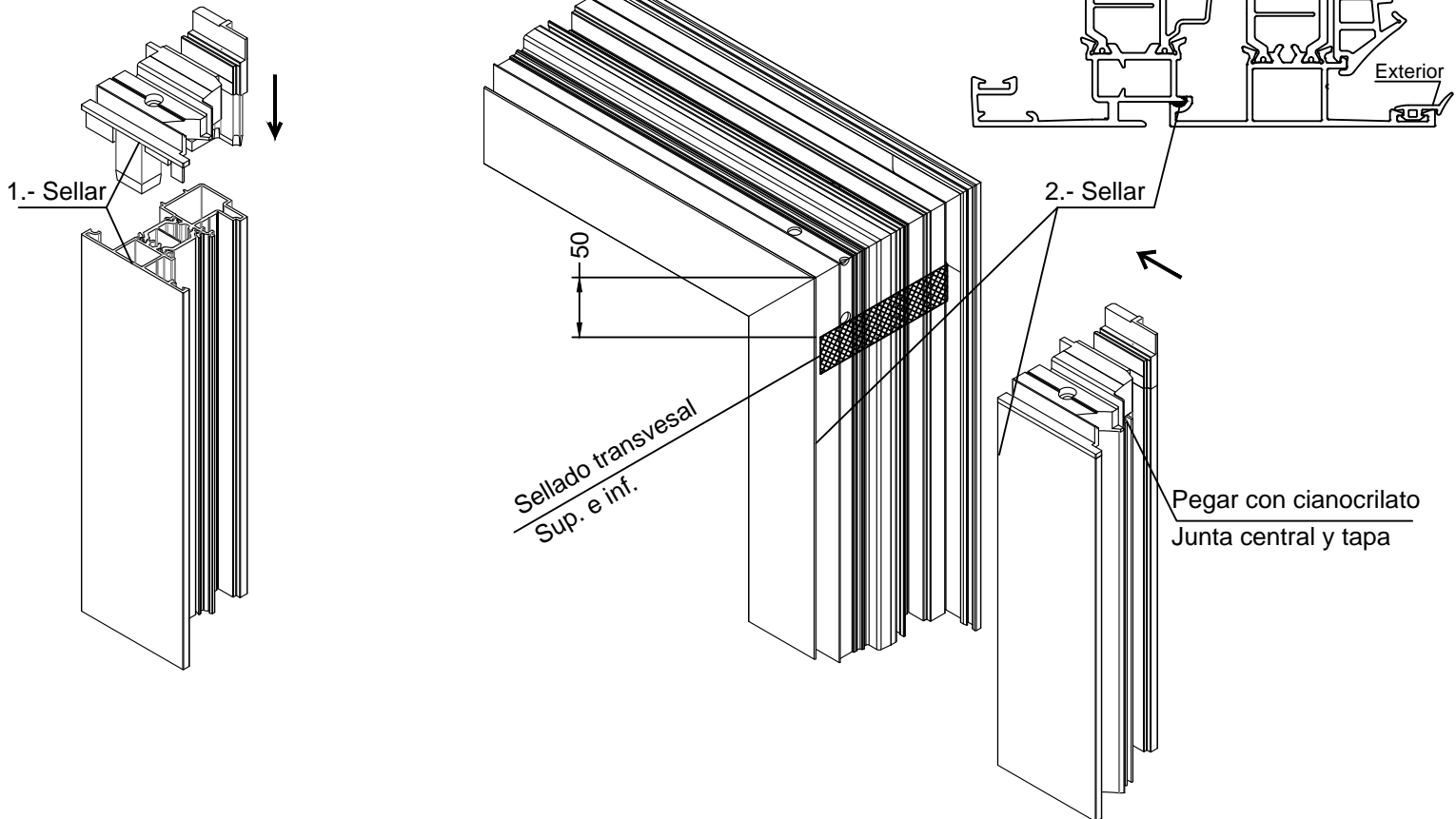

6A.- MONTAJE HOJAS EN MARCO

Ver hojas H5 (oscilo.activa), H6 (pasiva) y H7 (pract. ext. activa) para determinar herrajes necesarios según dimensiones
Comprobar huella entre marco y hoja, aproximándola a $6 \text{ mm} \pm 0,5$

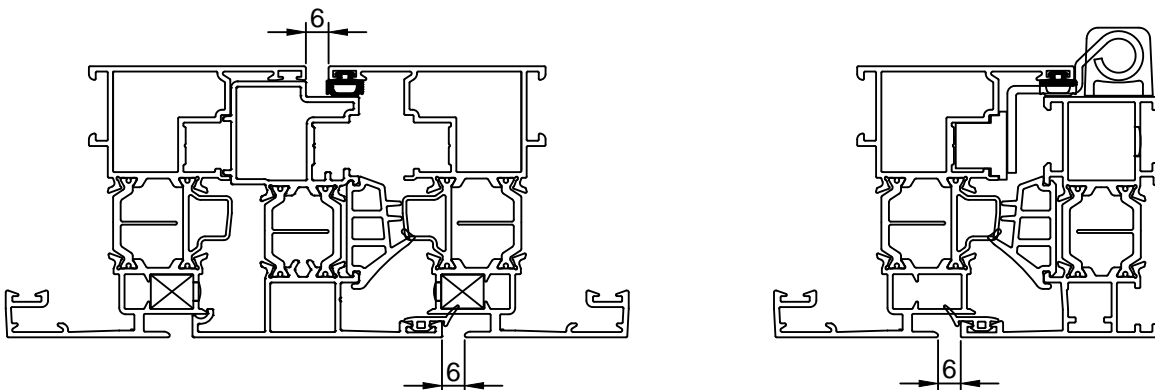

Fabricación

6B.- HERRAJE OSCILOBATIENTE - HOJA ACTIVA

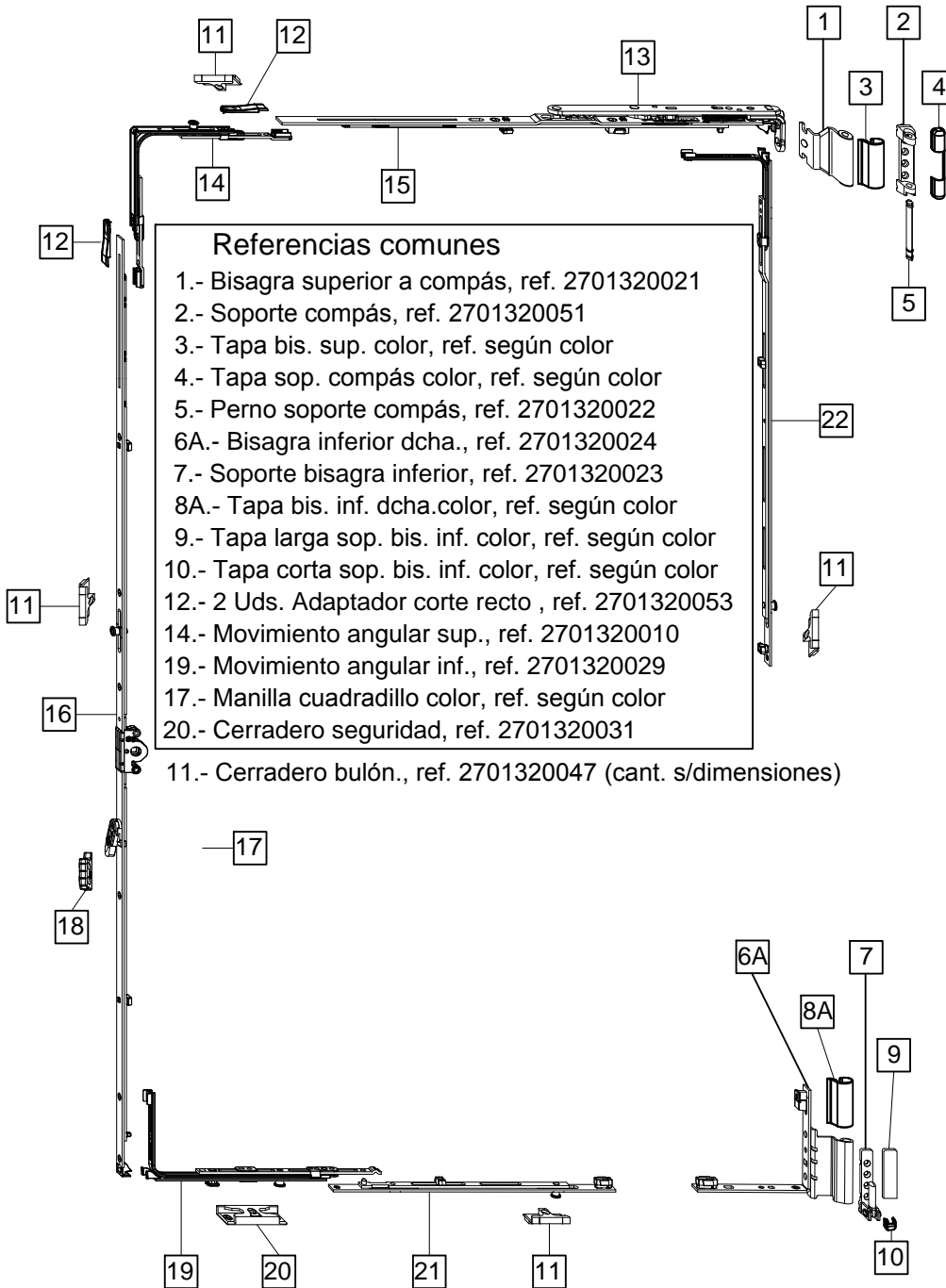

Nº	Descripción	Referencia según ancho hoja			
		401<600	601<800	801<1050	1051<1300
13	Brazo compás	2701320017	2701320018	2701320019	2701320057
15	Frontal copás	2701320013	2701320014	2701320015	2701320058
21	Cierre hor. central	—	—	2701320055	2701320055

Cant. Cerradero bulón ref. 2701320047	1	1	2	2
------------------------------------------	---	---	---	---

Nº	Descripción	Referencia según alto hoja										Cant. Cerrad. ref. 2701320047	
		431<660	661<800	801<840	841<1090	1091<1280	1281<1340	1341<1500	1501<1590	1591<1700	1701<1950		1951<2200
16	Falleba	2701320002	2701320003	2701320003	2701320004	2701320005	2701320005	2701320006	2701320006	2701320007	2701320008	2701320009	2701320009
22	Cierre lateral	—	—	2701320026	2701320026	2701320026	2701320027	2701320028	2701320028	2701320028	2701320028	2701320056	2701320056
18	Cerrad. elevador (32 Der.) s/ mano (33 Izq.)	—	2701320032	2701320032	2701320032	2701320032	2701320032	2701320032	2701320032	2701320032	2701320032	2701320032	2701320032
		—	2701320033	2701320033	2701320033	2701320033	2701320033	2701320033	2701320033	2701320033	2701320033	2701320033	2701320033
		—	1	2	2	2	3	4	4	5	5	7	7

Fabricación

6C.- HERRAJE OSCILOBATIENTE - HOJA PASIVA

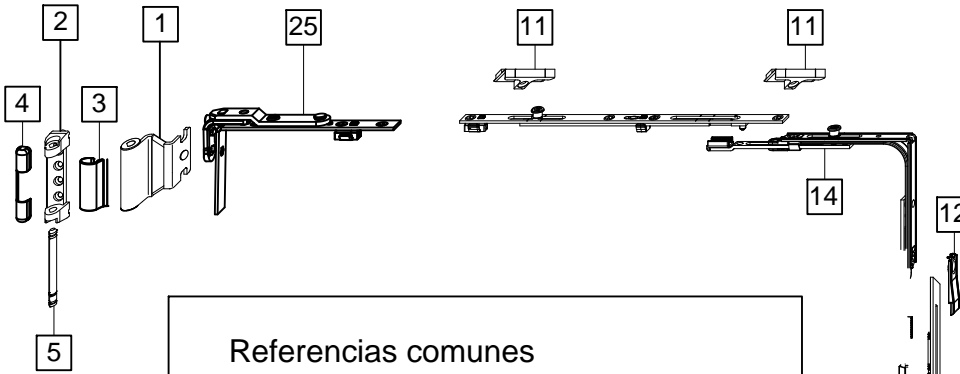

Referencias comunes	
1.-	Bisagra superior a compás, ref. 2701320021
2.-	Soporte compás, ref. 2701320051
3.-	Tapa bis. sup. color, ref. según color
4.-	Tapa sop. compás color, ref. según color
5.-	Perno soporte compás, ref. 2701320022
6B.-	Bisagra inferior izqda., ref. 2701320025
7.-	Soporte bisagra inferior, ref. 2701320023
8B.-	Tapa bis. inf. izq. color, ref. según color
9.-	Tapa larga sop. bis. inf. color, ref. según color
10.-	Tapa corta sop. bis. inf. color, ref. según color
12.-	Adaptador corte recto, ref. 2701320053
14.-	Movimiento angular sup., ref. 2701320010
20.-	Cerradero seguridad, ref. 2701320031
25.-	Falso compás, ref. 2701320044
29.-	Movimto. ang. inf. conex.rap., ref. 2701320041

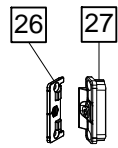

11.- Cerradero bulón., ref. 2701320047 (cant. s/dimensiones)

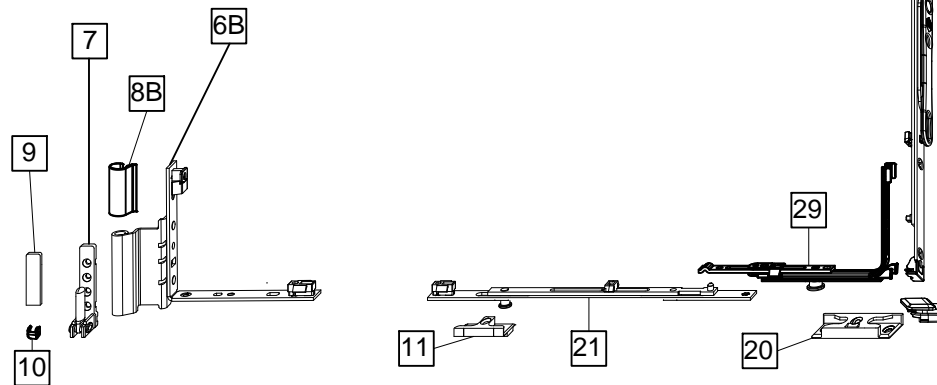

Nº	Descripción	Referencia según ancho hoja	
		401<800	801<1300
21	Cierre hor.central 2 Uds. (sup/inf.)	—	201751- - - -
	Cant. Cerradero bulón ref. 2701320047	1	3

Nº	Descripción	Referencia según alto hoja								
		431<660	661<840	841<1090	1091<1340	1341<1590	1591<1700	1701<1950	1951<2200	2201<2600
28	Falleba palanca	2701320034	2701320035	2701320036	2701320037	2701320038	2701320059	2701320039	2701320040	2701320060
26	Cierre presión oculto marco Ref. 2701320045	—	—	1 Ud.	1 Ud.	1 Ud.	2 Uds.	2 Uds.	2 Uds.	3 Uds.
27	Cierre presión oculto hoja Ref. 2701320046	—	—	1 Ud.	1 Ud.	1 Ud.	2 Uds.	2 Uds.	2 Uds.	3 Uds.
	Cant. Cerrad. ref. 2701320047	—	1	1	1	2	2	3	3	4

Fabricación

RT64 C16 - H7

7.- ACRISTALAMIENTO

- Elegir junquillo según espesor vidrio; ver en catalogo técnico a partir de la pag. D8
- Calzos
 - * La anchura de los calzos será, al menos = espesor total del vidrio
 - * Deben ser de material imputrescible y con dureza apropiada para soportar el peso y que no dañe los cantos del vidrio
- Colocar calzos de acristalamiento según esquemas abajo; la distancia a la esquina del vidrio será mínimo de 50 mm
- A fin de mejorar el aislamiento acústico, el vidrio no debe estar en contacto con los perfiles en ningún punto

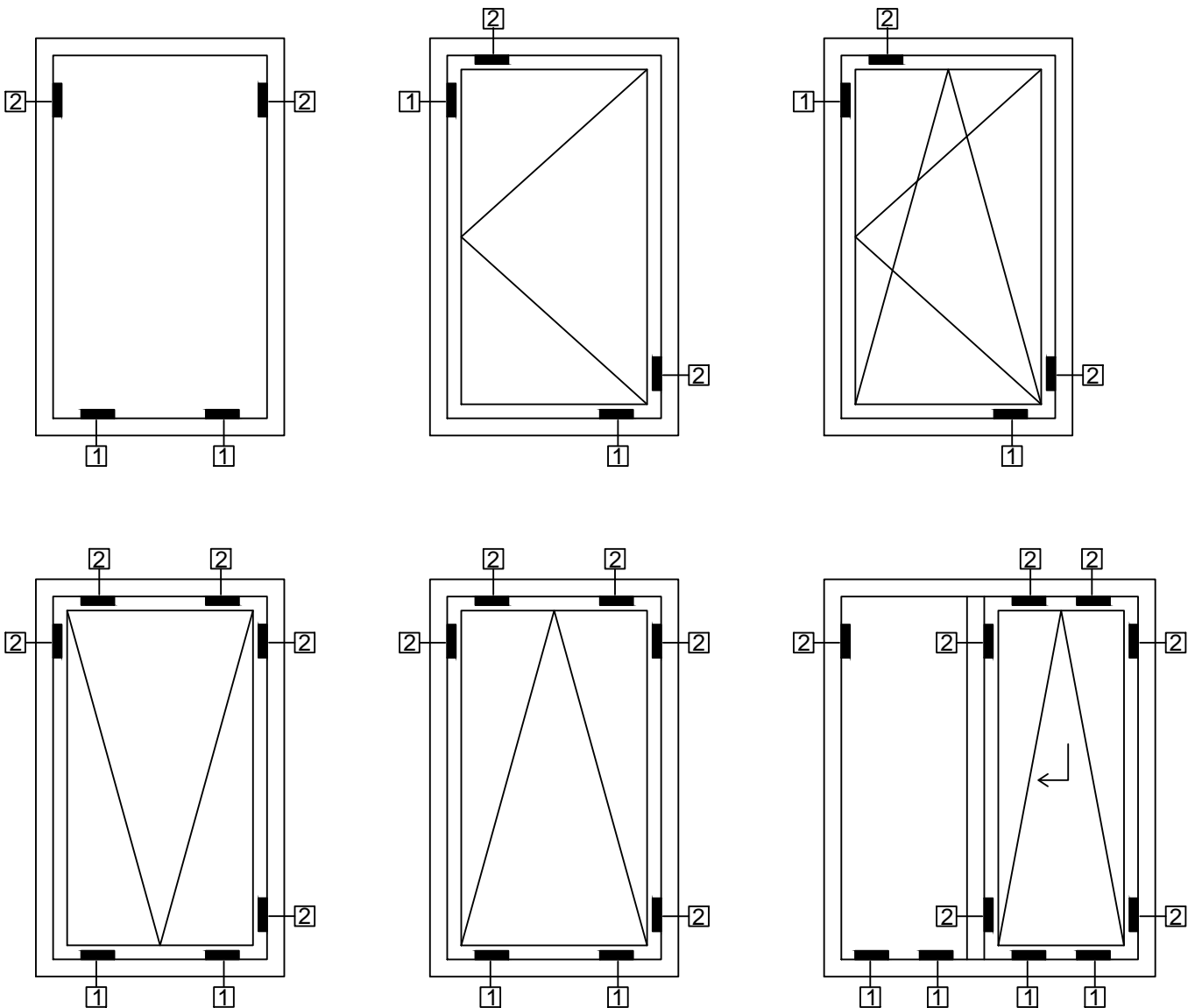

1 = Calzo de apoyo

2 = Calzo de colocación

Fabricación

RT64 C16 - H8

8.- TROQUEL

Esquema de posiciones de mecanizado

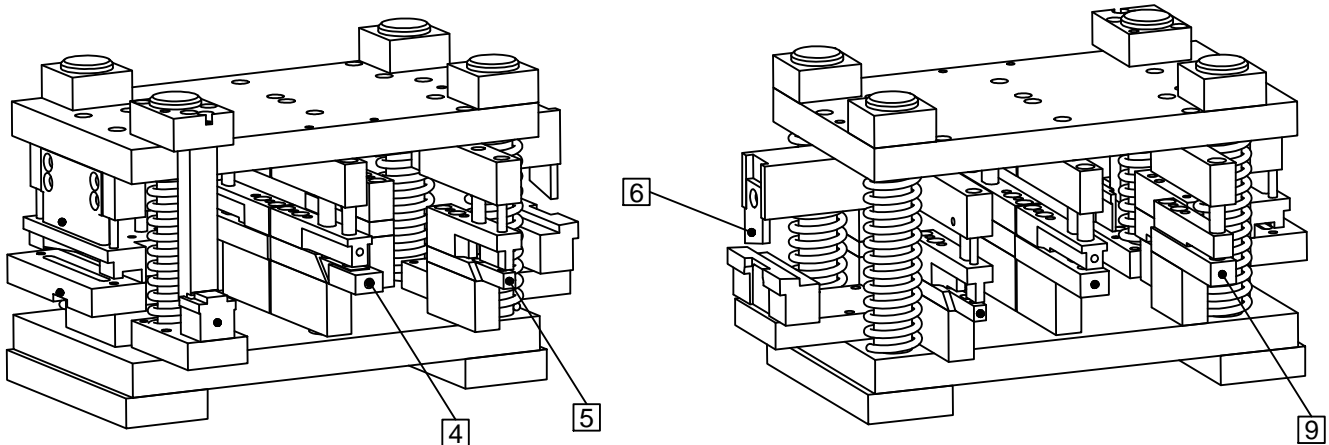

4.- Esc.extrusión principal

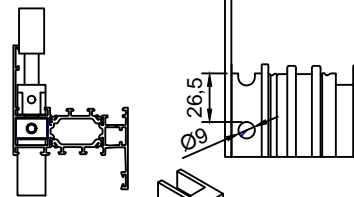

En perfil hoja: - Retirar U
- Acercar poliamida a la sufridera

5.- Esc.extrusión secundaria

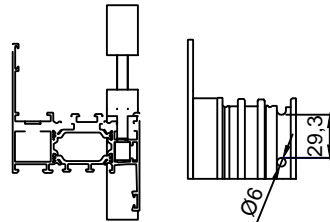

6.- Salida de aguas

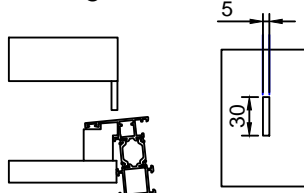

9.- Tope T.

