

- ÍNDICE -

A.- Descripción Técnica

B.- Relación perfiles

C.- Accesorios y juntas

D.- Perfiles a escala

F.- Hojas de corte

G.- Secciones tipo

H.- Fabricación

Características técnicas



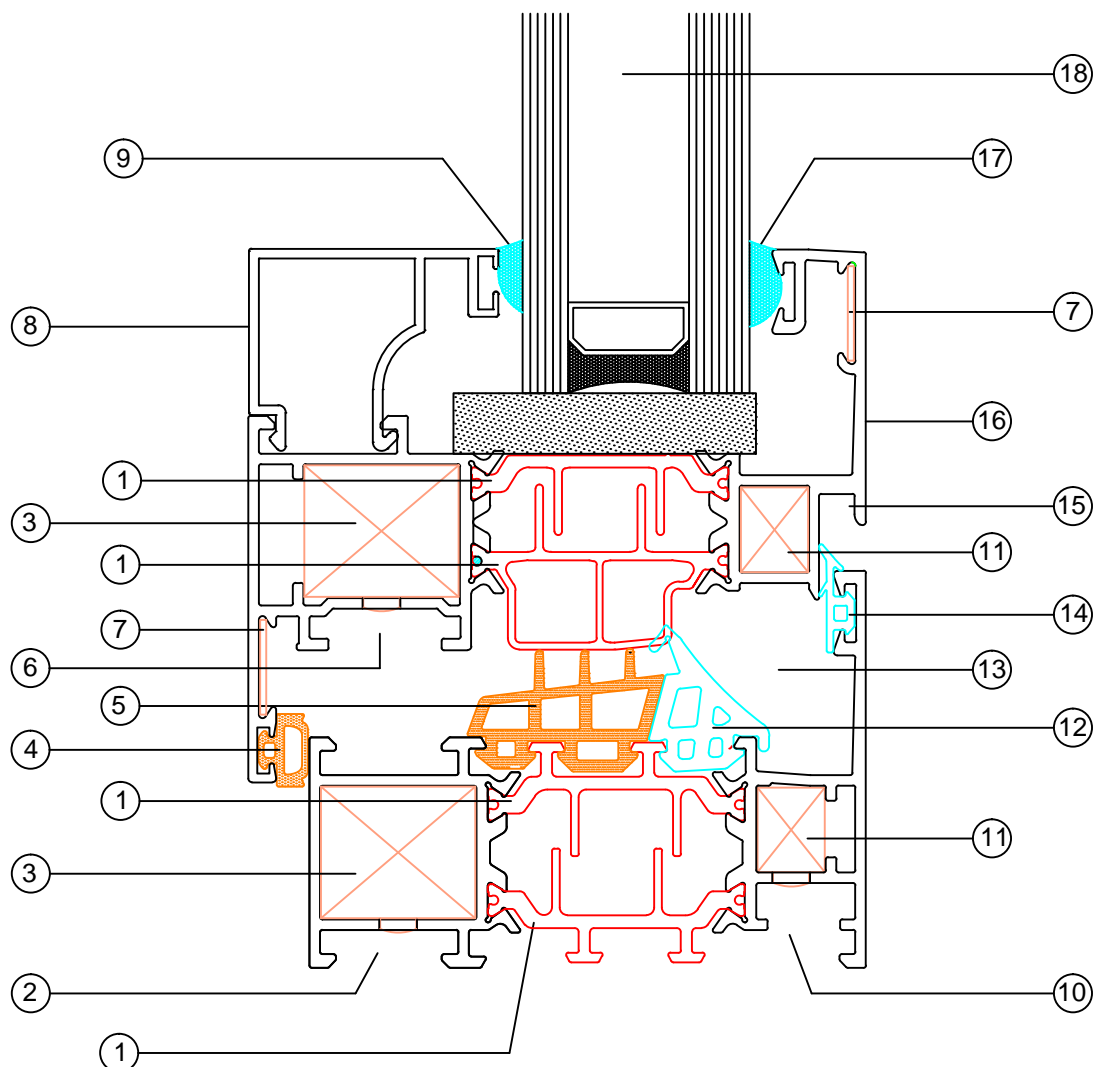

RT74 CE - A1



- | | |
|--|--|
| ① Rotura térmica con poliamidas de 34 mm | ⑩ Posibilidad de vierteaguas exterior o condensador |
| ② Posibilidad recercado interior | ⑪ Escuadra exterior con tetón de resorte ó extrusión |
| ③ Escuadra interior con tetón de resorte ó extrusión | ⑫ Junta central en EPDM |
| ④ Junta interior espumosa | ⑬ Amplia cámara evacuación agua exterior |
| ⑤ Junta central espumosa para aislamiento térmico | ⑭ Posibilidad de junta exterior en EPDM |
| ⑥ Accesorios cámara europea | ⑮ Amplio vierteaguas exterior en hoja |
| ⑦ Escuadra alineamiento en inox. | ⑯ Hoja coplanar |
| ⑧ Junquillos acristalar 22 mm rectos o curvos | ⑰ Sellado con silicona o junta EPDM |
| ⑨ Sellado con silicona o junta EPDM | ⑱ Amplia posibilidad de acristalamiento |

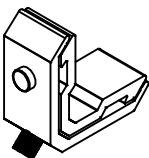
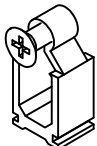

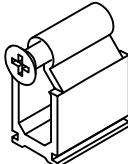
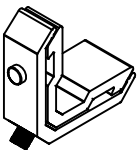
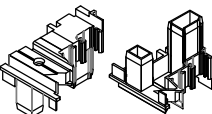
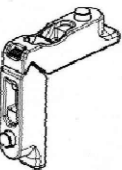
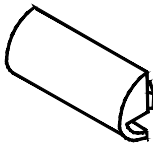
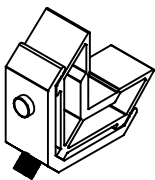
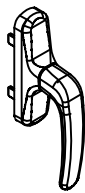
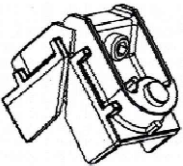

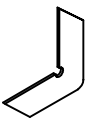
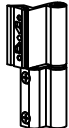



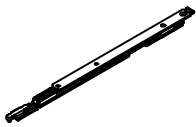

Relación de accesorios

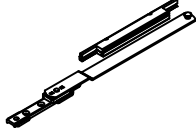
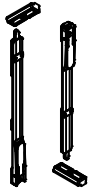
RT74 CE - C1

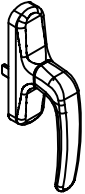
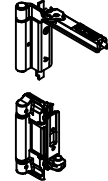
Ref.	Esquema	Descripción	Ref.	Esquema	Descripción
0701070045		Escuadra 17 x 20 extrusión	0701070047		Tope travesaño 17 mm
		Escuadra 17 x 20 inyección	0701070035		Tope travesaño 36 mm
0701070046		Escuadra 11 x 9 extrusión	0901330002		Juego tapa inversora
		Escuadra 11 x 9 inyección	1103170002		Tapa salida agua
0701070048		Escuadra 36 x 20 extrusión	03**010001 ** = 02 L/Blanco ** = 03 L/Negro		Cremona practicable apt. interior
		Escuadra 36 x 20 inyección	0417010001		Kit cierre practicable apt. interior
0708090001		Escuadra alineamiento	06**2010001 ** = 02 L/Blanco ** = 03 L/Negro		Bisagra practicable derecha

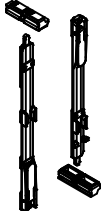

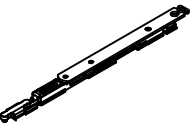

Relación de accesorios

RT74 CE - C2

Ref.	Esquema	Descripción	Ref.	Esquema	Descripción
06**010002 ** = 02 L/Blanco ** = 03 L/Negro		Bisagra practicable izquierda	0101010003		Compás oscilobatiente grande (<581<1700)
0407010004		Cerradero superior/inferior	0101010004		Compás oscilobatiente suplementario (>1000)
0501010002		Juego pasadores practicable hoja pasiva			Cierre suplementario vertical
03**010002 ** = 02 L/Blanco ** = 03 L/Negro		Cremona oscilobatiente	0202010003		Conjunto bisagras simétricas
0202010001		Conjunto oscilobatiente	0501010001		Juego pasadores oscilobatiente hoja pasiva
0101010001		Compás oscilobatiente pequeño (<370<470)			Cierre central oculto hoja pasiva oscilo.
0101010002		Compás oscilobatiente mediano (<471<580)			Terminal pletina de cierre

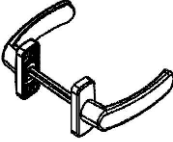

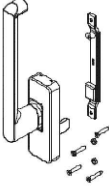
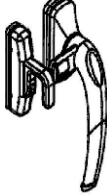
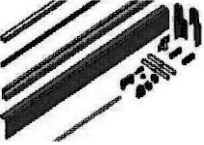

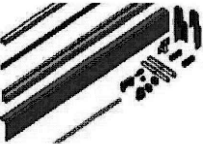
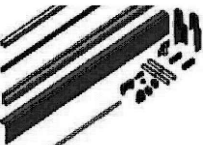
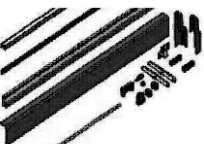
Relación de accesorios

RT74 CE - C3

Ref.	Esquema	Descripción	Ref.	Esquema	Descripción
		Manilla P.E. doble			Manilla practicable apert. exterior
18010100++ ++ = 05 Izquierda ++ = 06 Derecha		Kit base OPL-AL			Caja embutir 40 mm
18**0100++ ** = 02 L/Blanco ** = 03 L/Negro ++ = 01 Izquierda ++ = 02 Derecha		Cremona interior osciloparalela			Cierre presión
18** 010003 ** = 02 L/Blanco ** = 03 L/Negro		Kit guías 1 (740-1200/2500)			Juego compás P.D.
18** 010004 ** = 02 L/Blanco ** = 03 L/Negro		Kit guías 2 (1201-1600/3000)			
18** 010005 ** = 02 L/Blanco ** = 03 L/Negro		Kit guías 3 (1601-1850/3000)			
18** 010006 ** = 02 L/Blanco ** = 03 L/Negro		Kit guías 4 (1851-2000/4000)			

Relación de juntas

RT74 CE - C4

Ref.	Esquema	Descripción	Ref.	Esquema	Descripción
0803150008		Junta estanqueidad central (EPDM)			
0803150009		Junta central suplemento térmico (Espumosa)			
0803040015		Junta exterior (EPDM)			
0803050002		Junta interior (espumosa)			
		Junta suplemento térmico bajo vidrio (celular)			

Perfiles escala 1:1

RT74 CE - D1

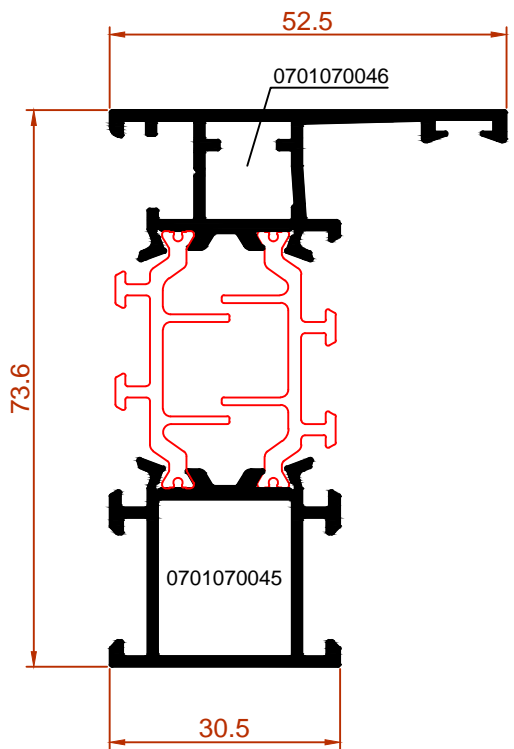

74-01 $I_{xx} = 29,84 \text{ cm}^4$
 $I_{yy} = 5,81 \text{ cm}^4$

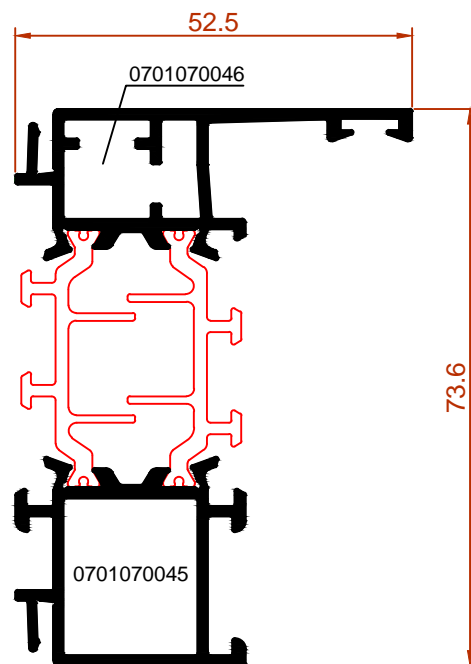

74-86 $I_{xx} = 30,29 \text{ cm}^4$
 $I_{yy} = 6,16 \text{ cm}^4$

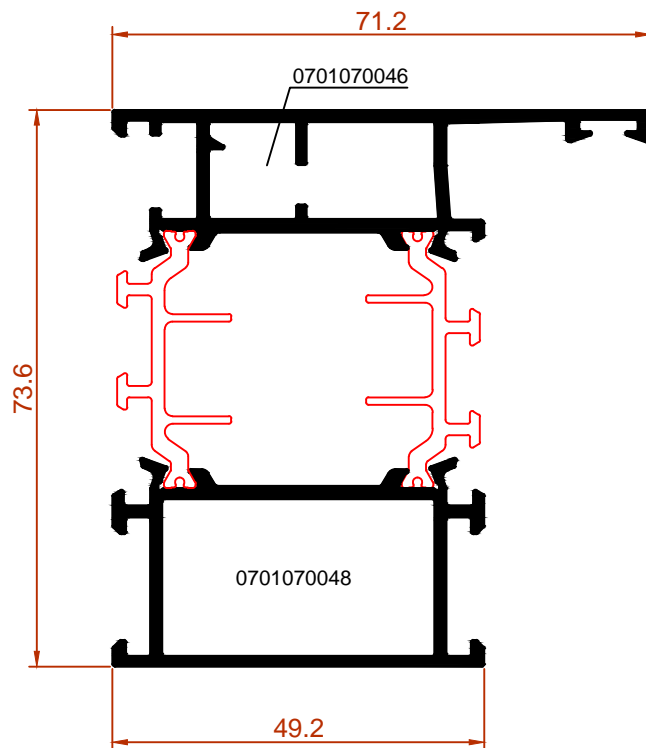

74-14 $I_{xx} = 41,12 \text{ cm}^4$
 $I_{yy} = 17,47 \text{ cm}^4$

Perfiles escala 1:1

RT74 CE - D2

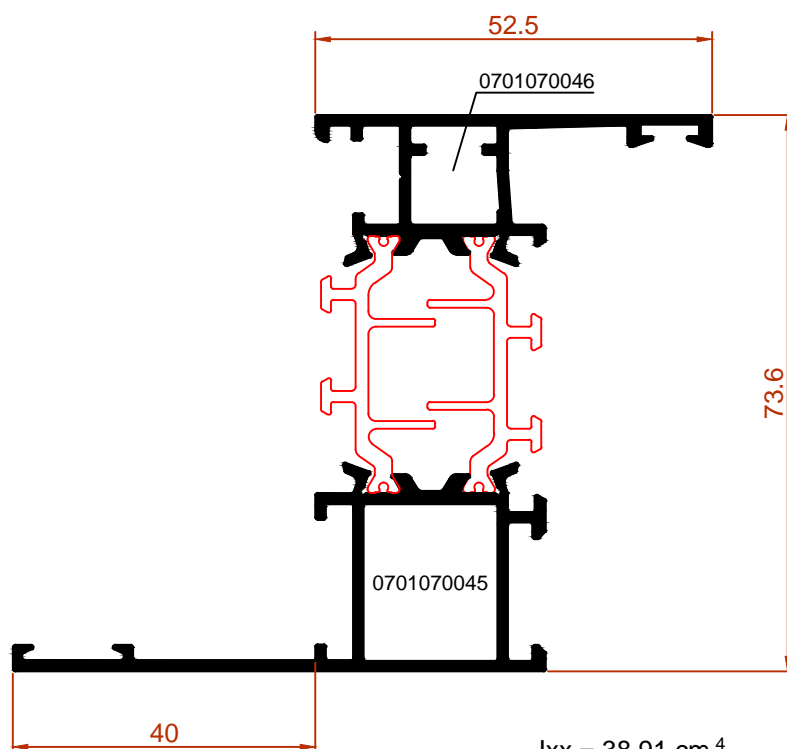

74-01L $I_{xx} = 38,91 \text{ cm}^4$
 $I_{yy} = 15,93 \text{ cm}^4$

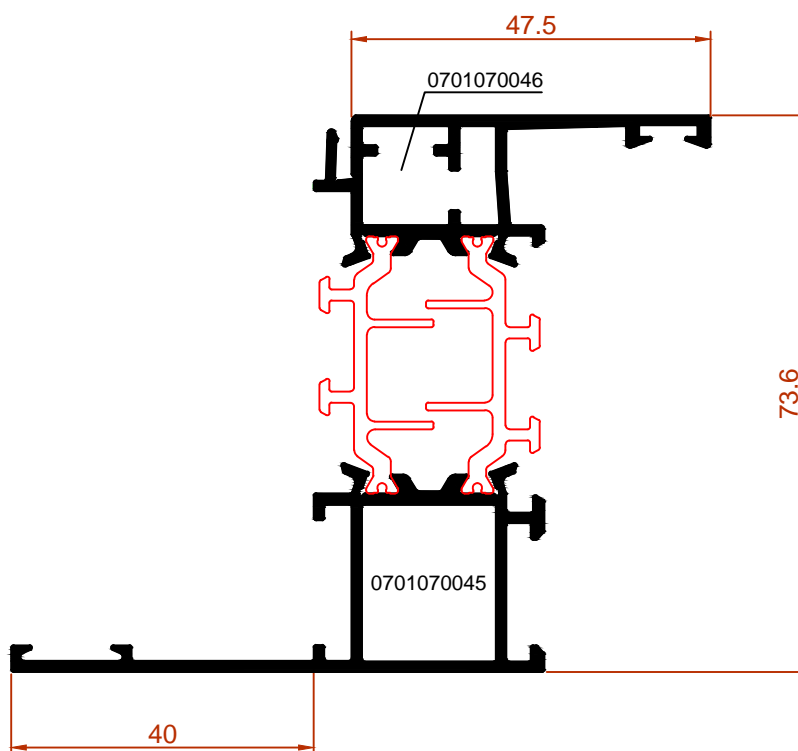

74-82 $I_{xx} = 39,52 \text{ cm}^4$
 $I_{yy} = 16,04 \text{ cm}^4$

Perfiles escala 1:1

RT74 CE - D3

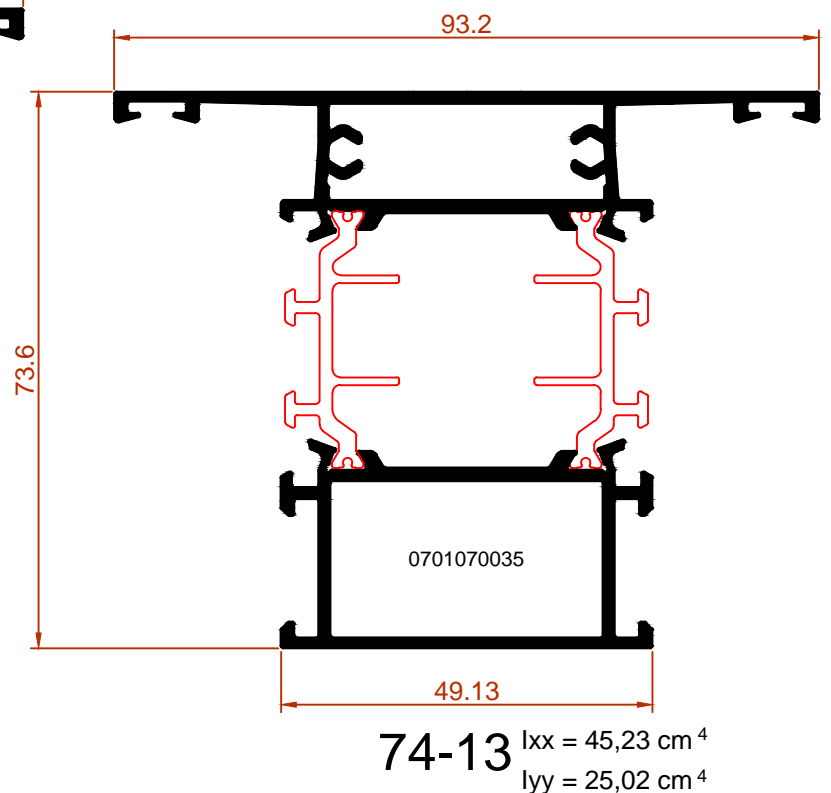
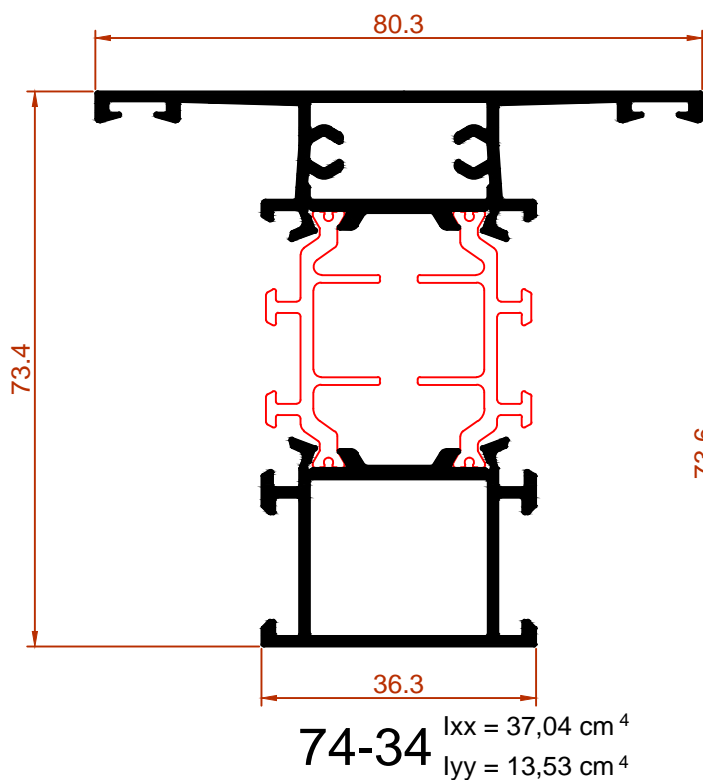
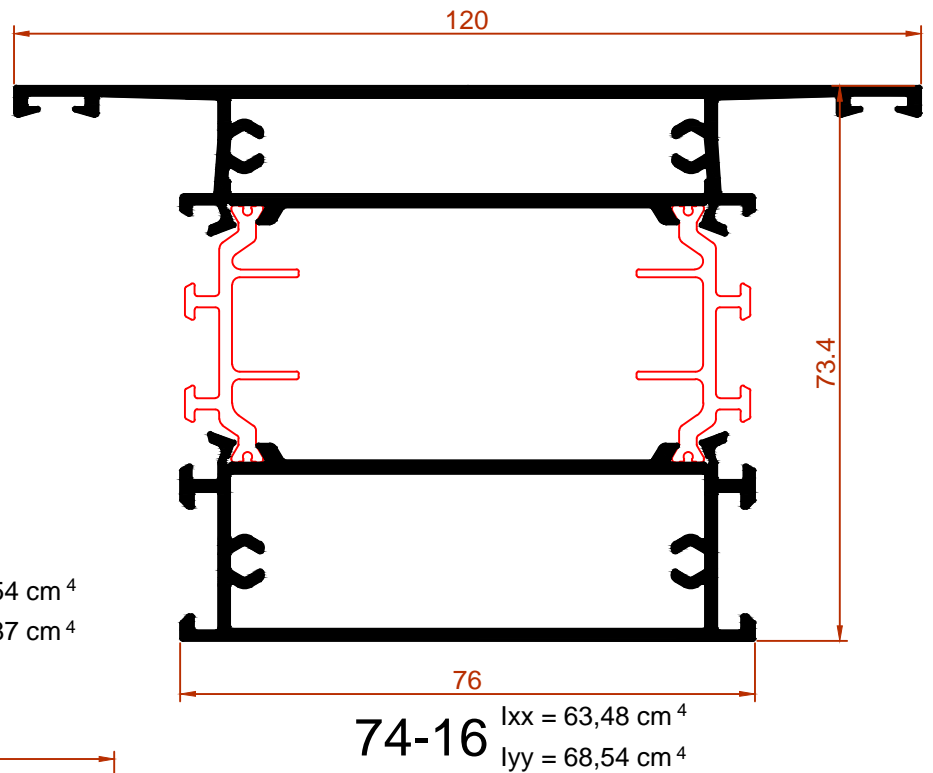
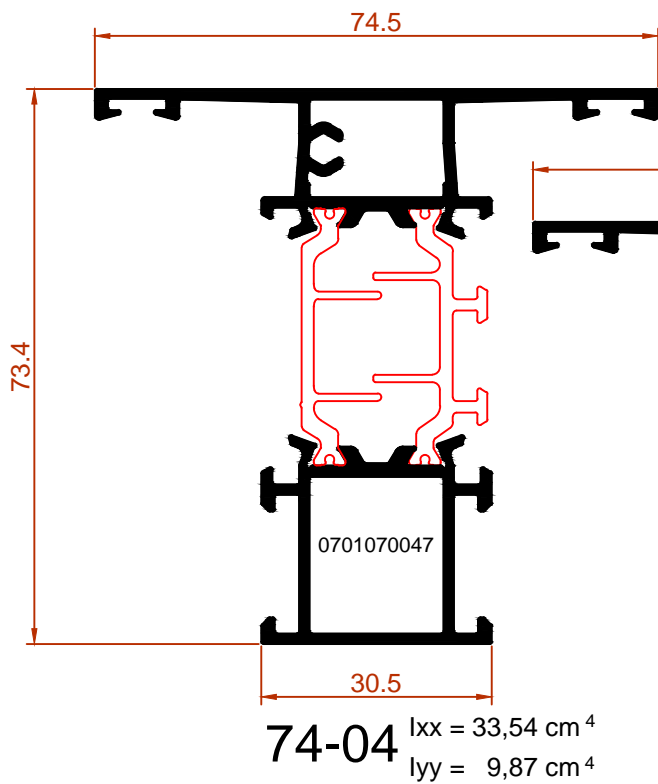

Perfiles escala 1:1

RT74 CE - D4

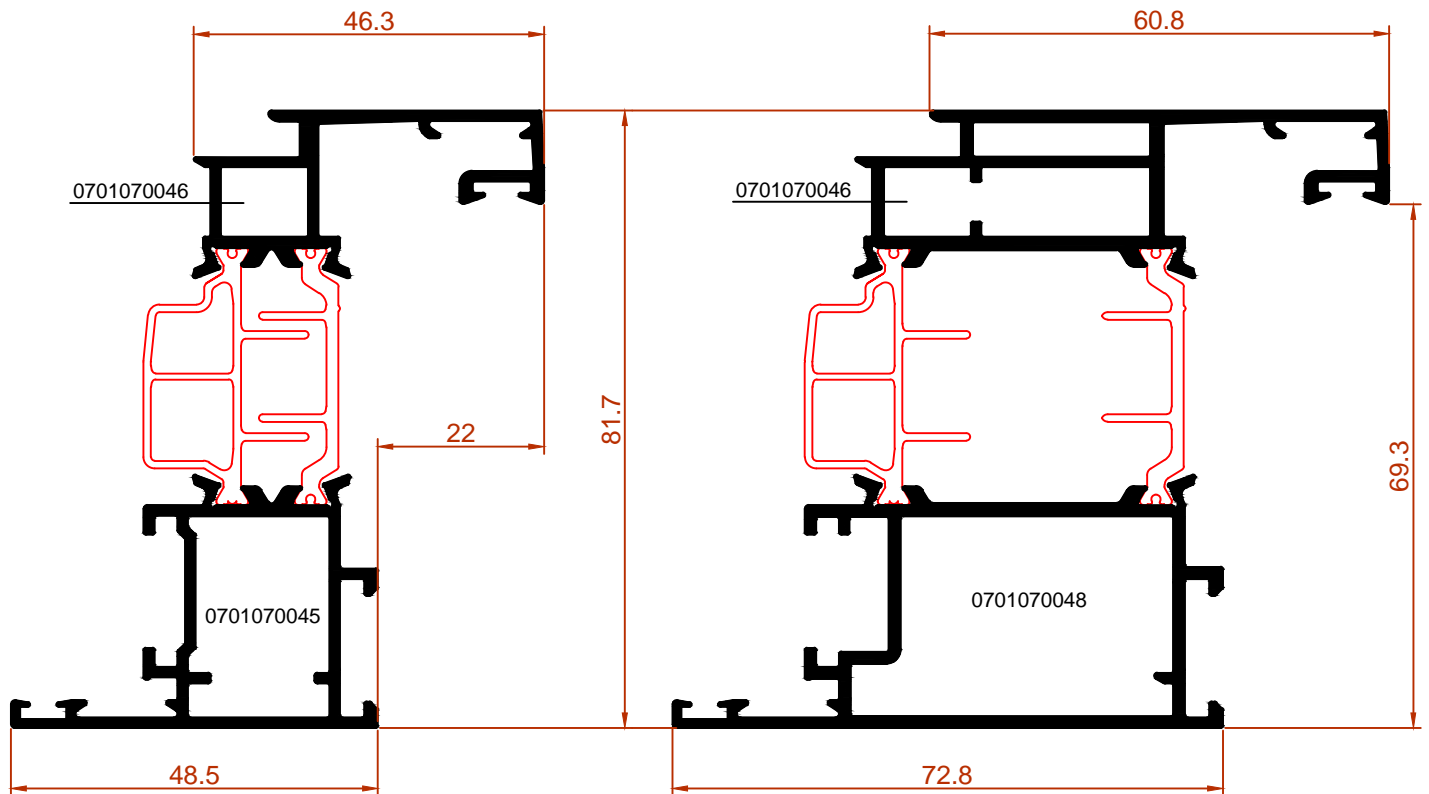

74-02 $I_{xx} = 43,67 \text{ cm}^4$
 $I_{yy} = 10,87 \text{ cm}^4$

74-15 $I_{xx} = 66,33 \text{ cm}^4$
 $I_{yy} = 32,70 \text{ cm}^4$

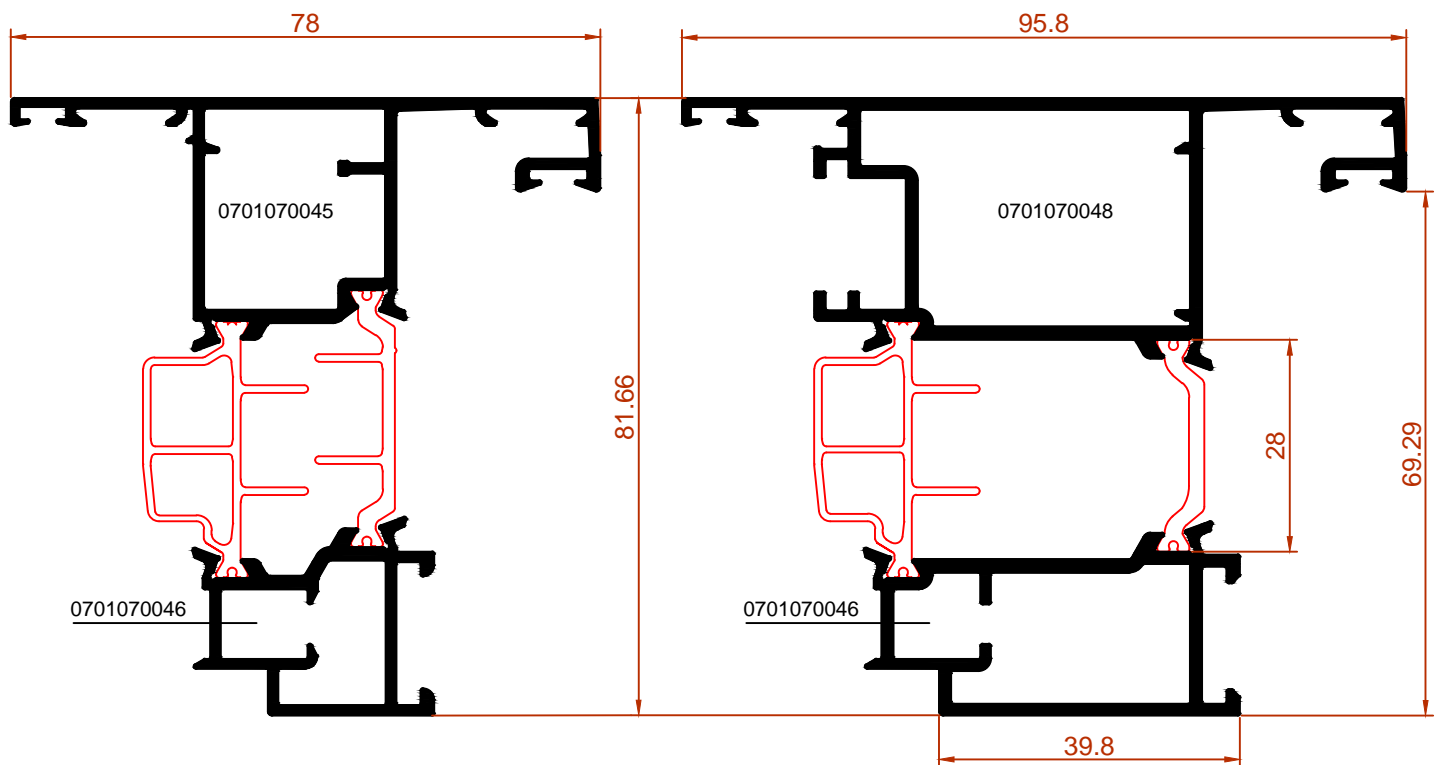

74-25

74-11 $I_{xx} = 60,17 \text{ cm}^4$
 $I_{yy} = 34,37 \text{ cm}^4$

Perfiles escala 1:1

RT74 CE - D5

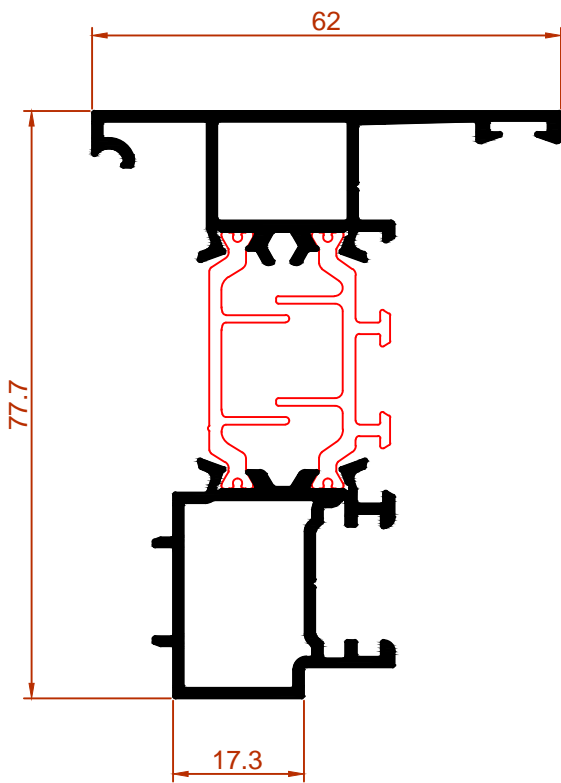

74-03 $I_{xx} = 34,14 \text{ cm}^4$
 $I_{yy} = 7,47 \text{ cm}^4$

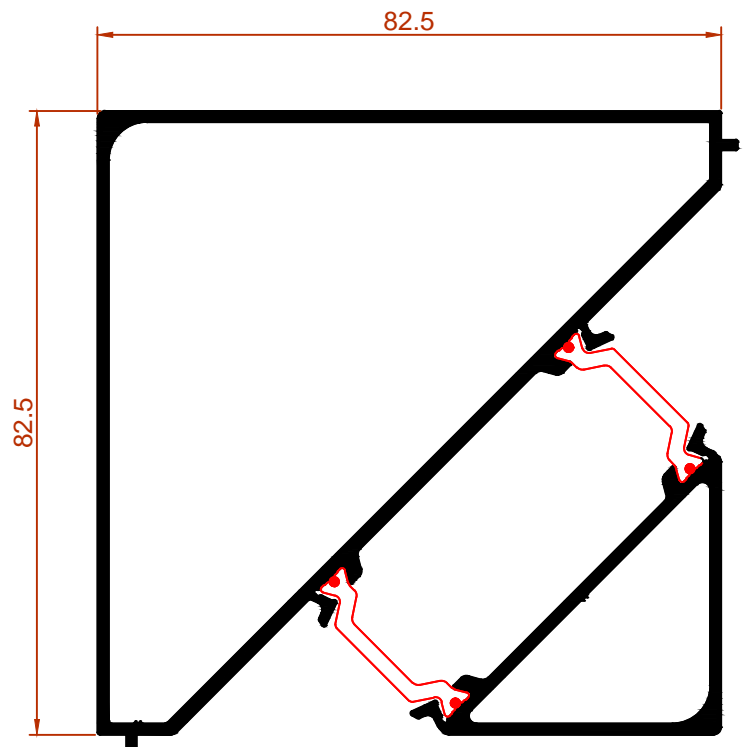

RTA72-08 $I_{xx} = 60,20 \text{ cm}^4$
 $I_{yy} = 60,20 \text{ cm}^4$

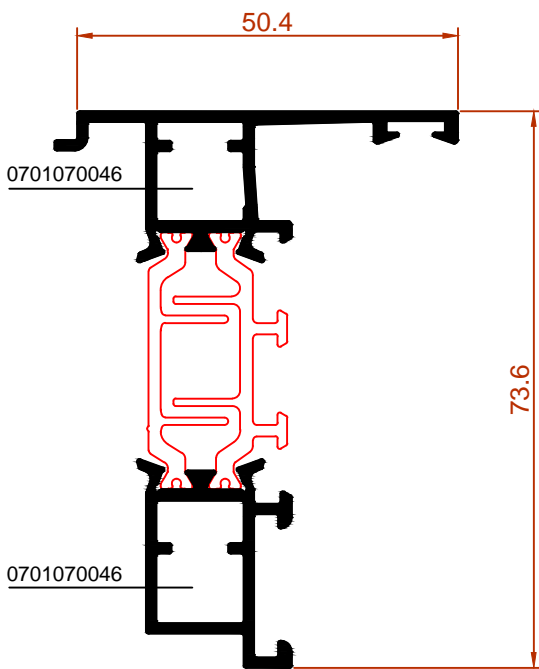

74-26 $I_{xx} = 23,51 \text{ cm}^4$
 $I_{yy} = 3,81 \text{ cm}^4$

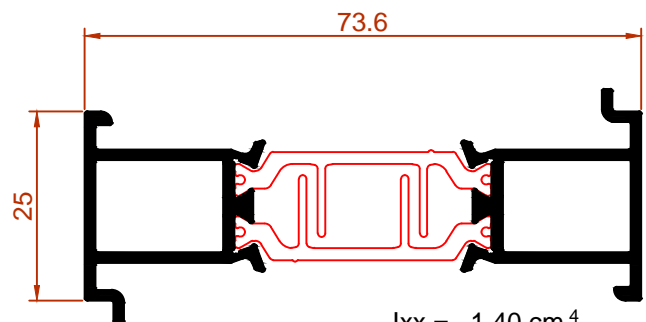

74-07 $I_{xx} = 1,40 \text{ cm}^4$
 $I_{yy} = 21,39 \text{ cm}^4$

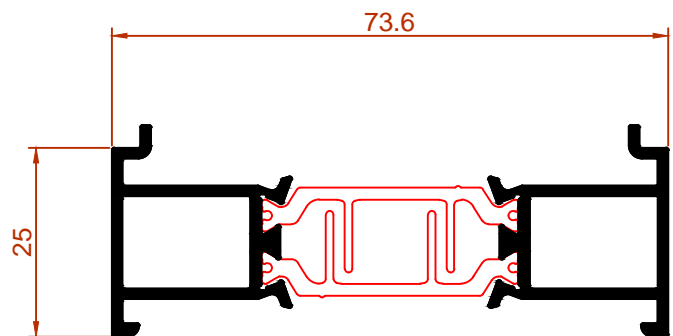

74-28 $I_{xx} = 1,39 \text{ cm}^4$
 $I_{yy} = 21,38 \text{ cm}^4$

Perfiles escala 1:1

RT74 CE - D6

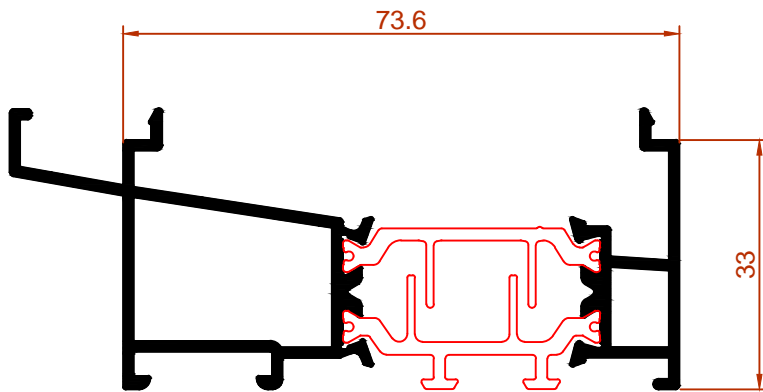

74-24

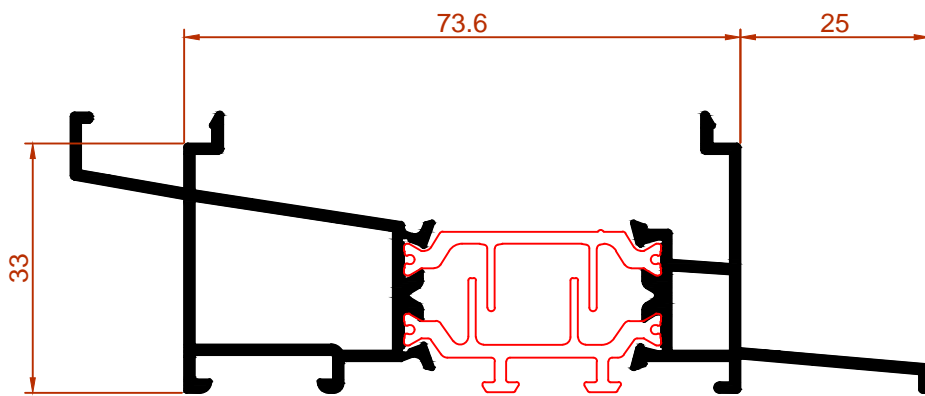

74-05

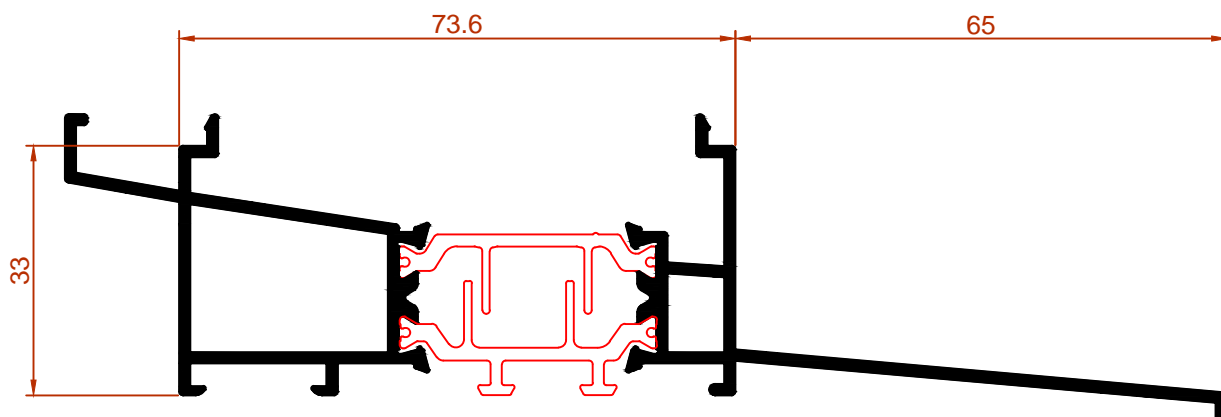

74-06

Perfiles escala 1:1

RT74 CE - D7

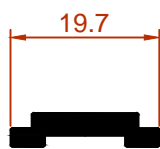
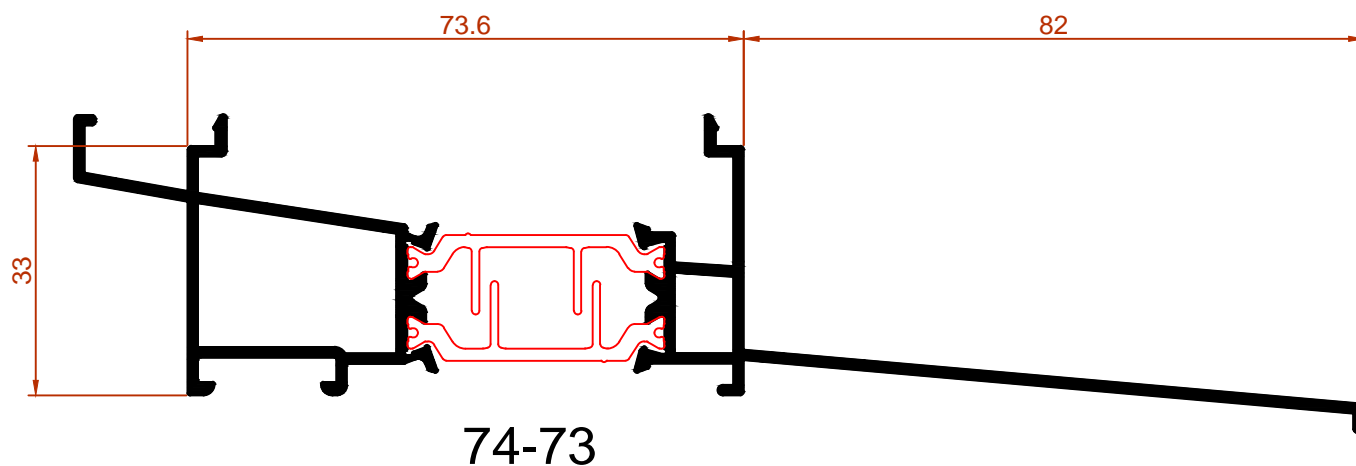

BX-51

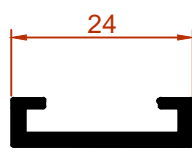

GFT-39

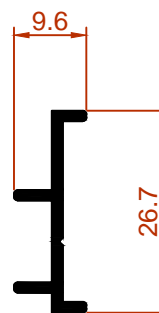

GALI-1022

Perfiles escala 1:1

RT74 CE - D8

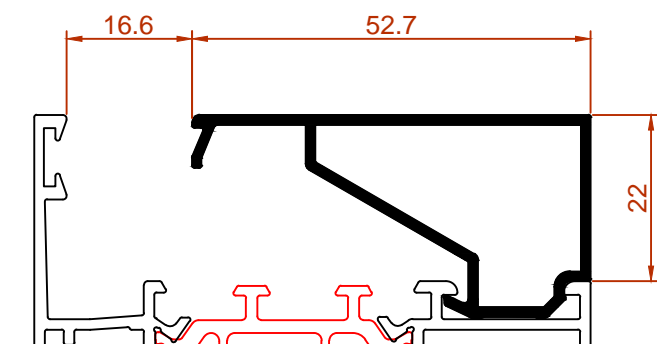

S90-66E

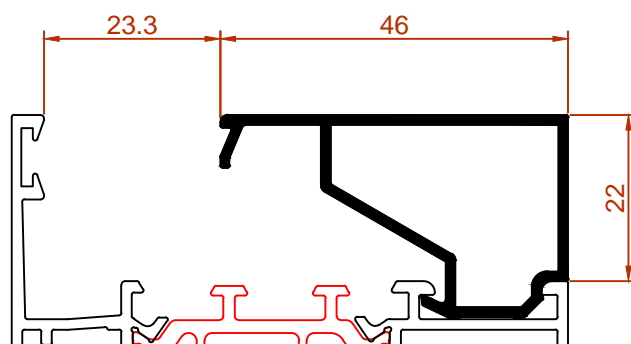

S90-67E

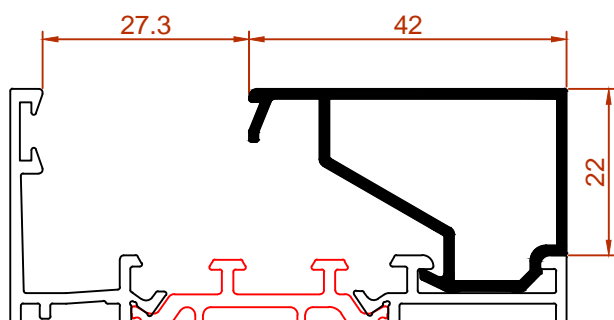

S90-68E

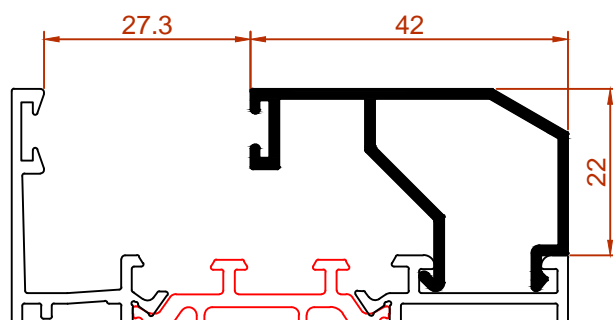

S90-95E

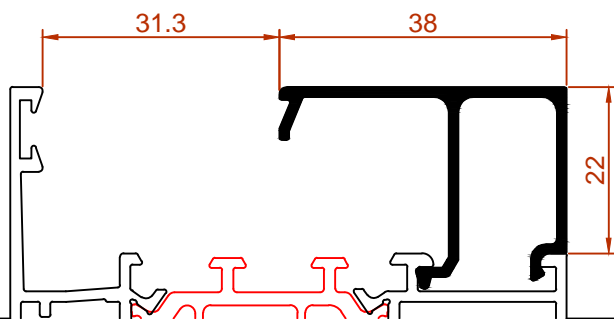

S90-65E

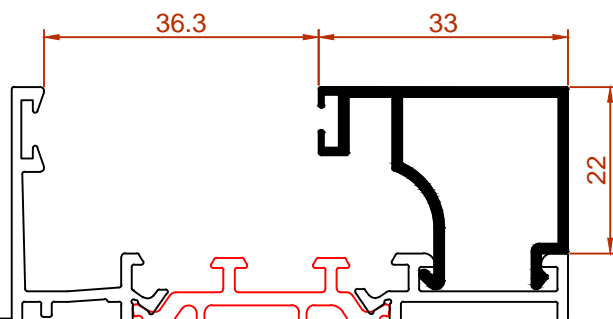

S90-50E

Perfiles escala 1:1

RT74 CE - D9

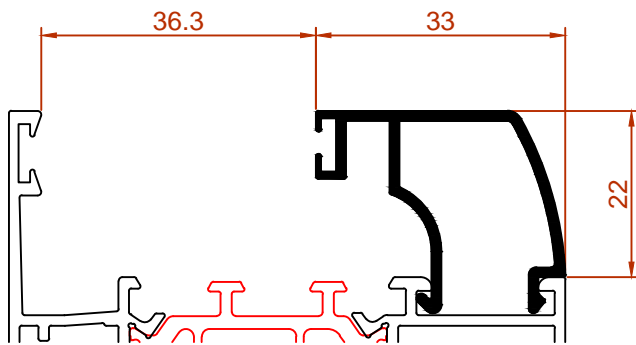

S90-90E

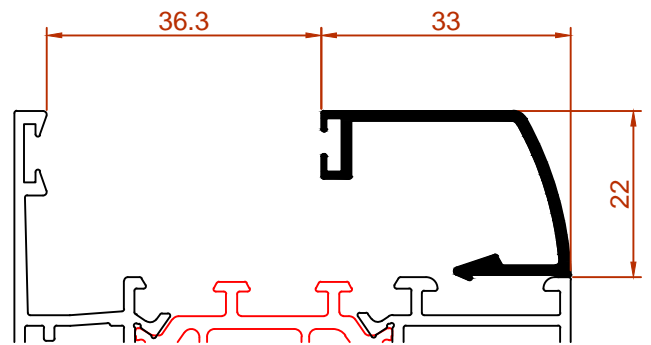

S90-91E

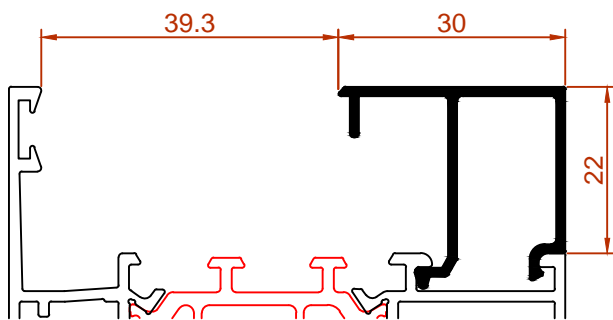

S90-54E

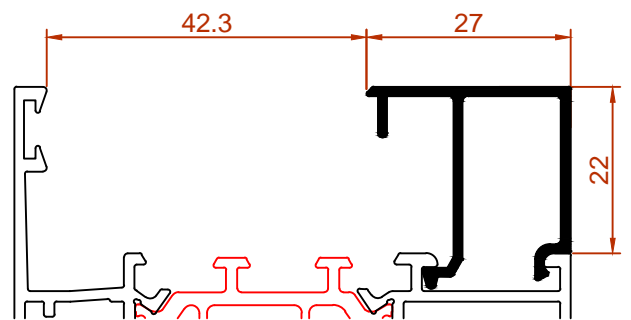

S90-56E

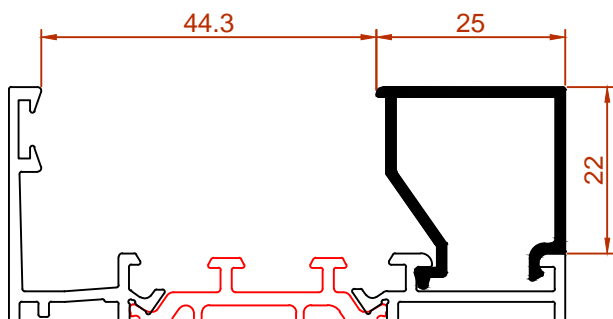

S90-51E

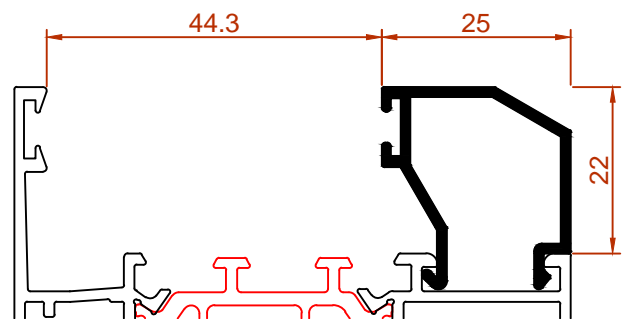

S90-94E

Perfiles escala 1:1

RT74 CE - D10

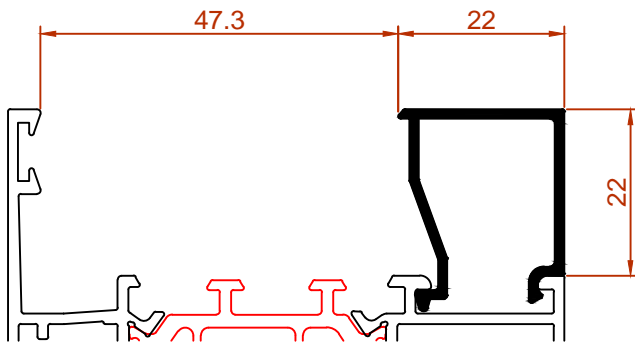

S90-64E

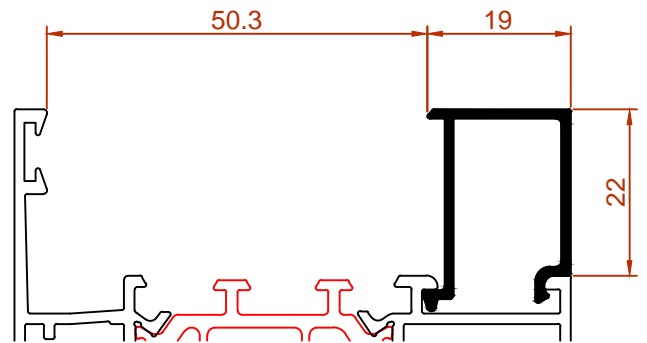

S90-52E

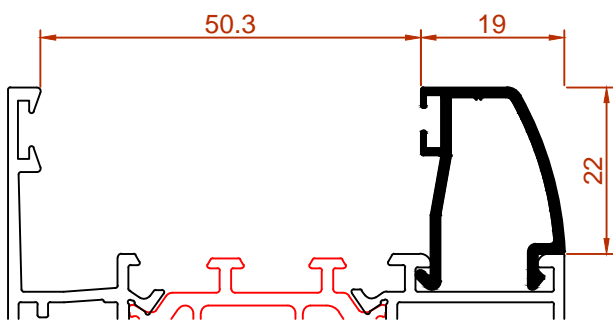

S90-96E

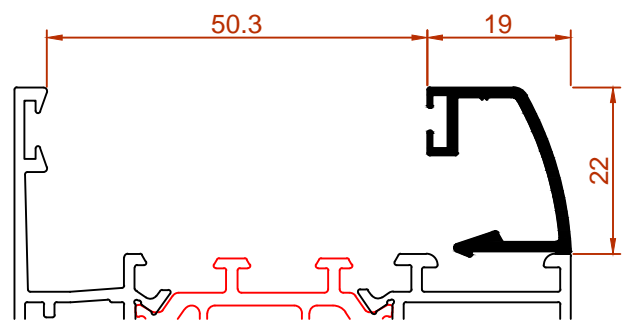

S90-97E

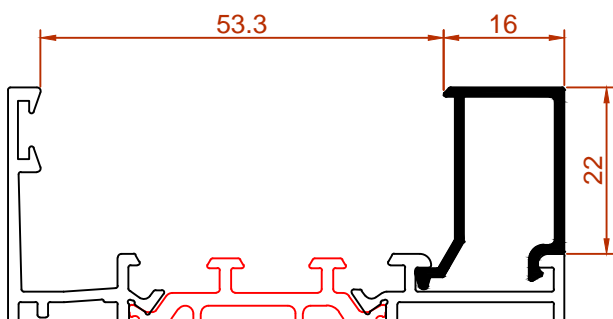

S90-57E

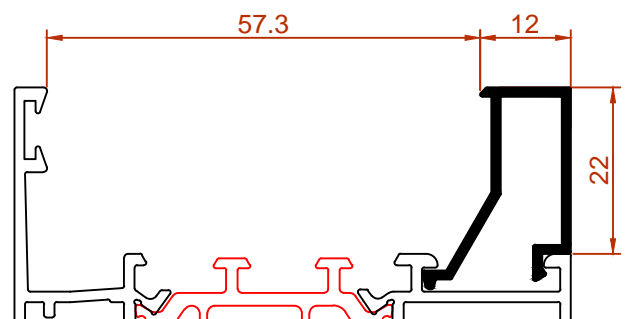

B90-55E

Perfiles escala 1:1

RT74 CE - D11

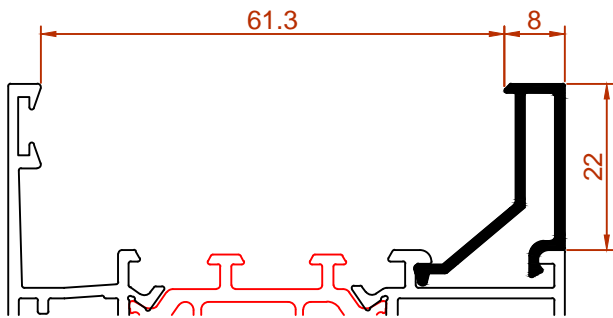

S90-58E

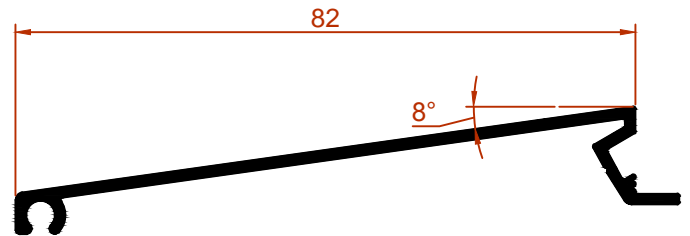

GALI-1106

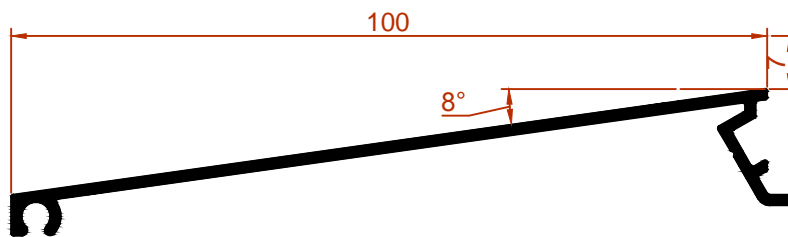

GALI-1119V

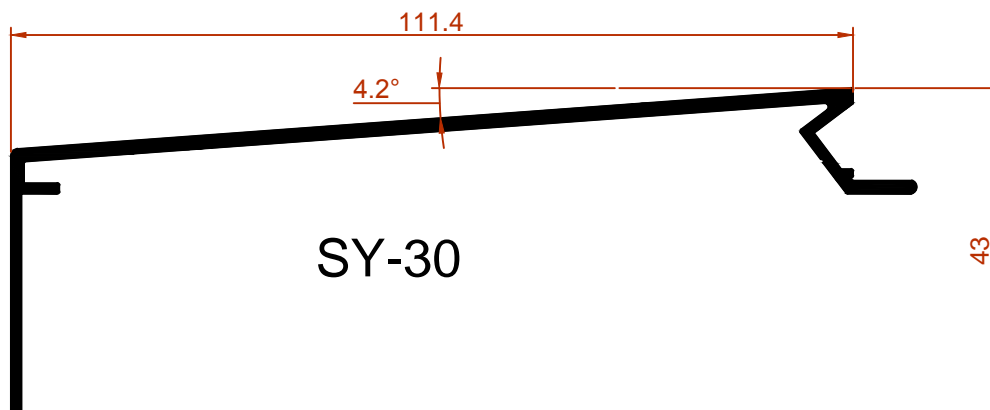

SY-30

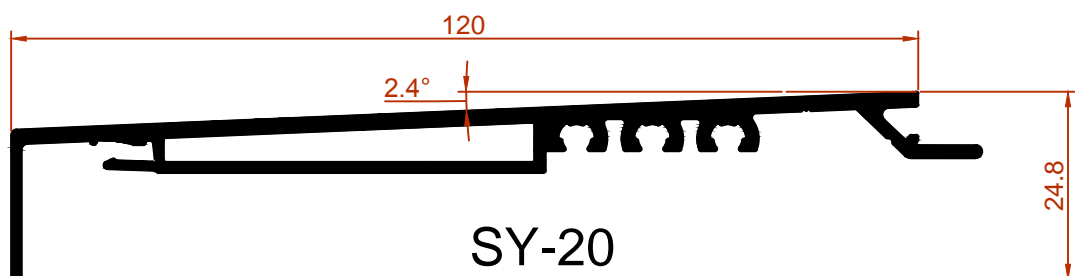

SY-20

Perfiles escala 1:1

RT74 CE - D12

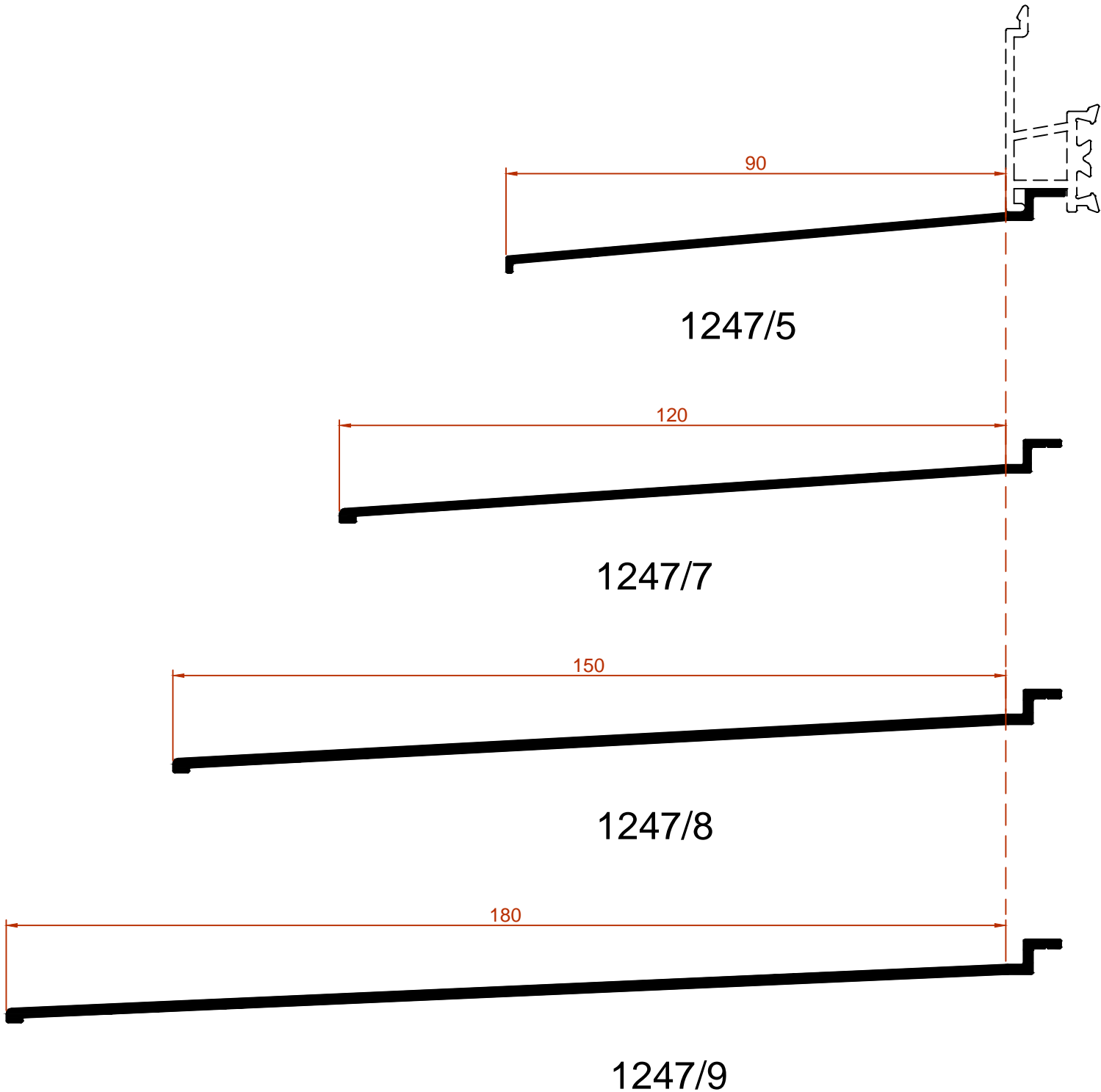

Perfiles escala 1:1

RT74 CE - D13

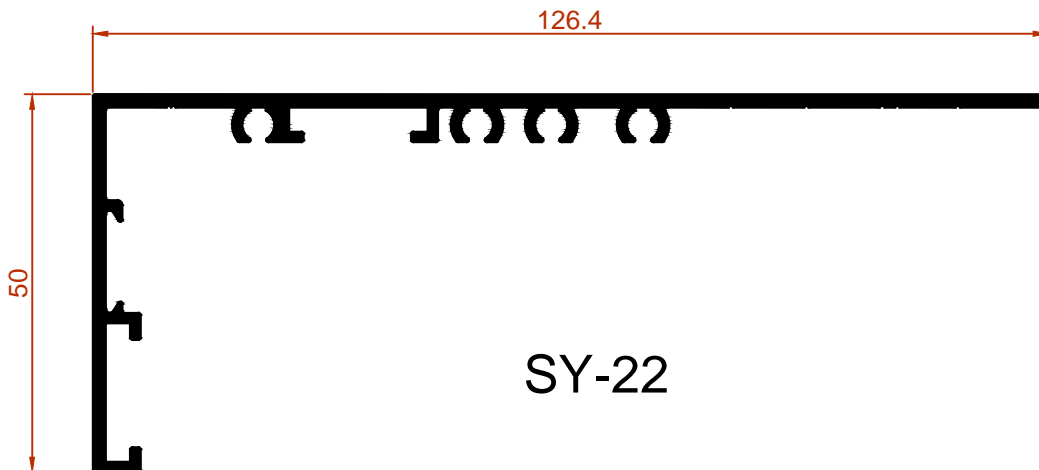
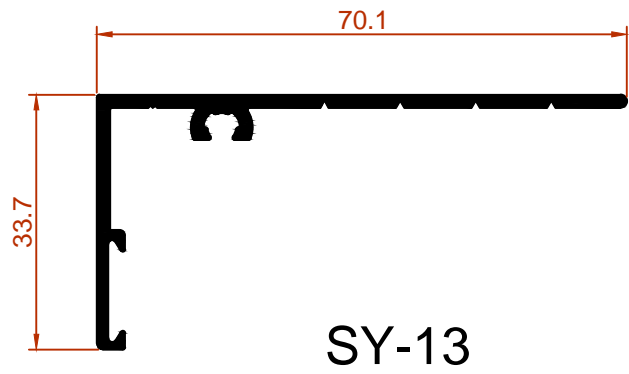
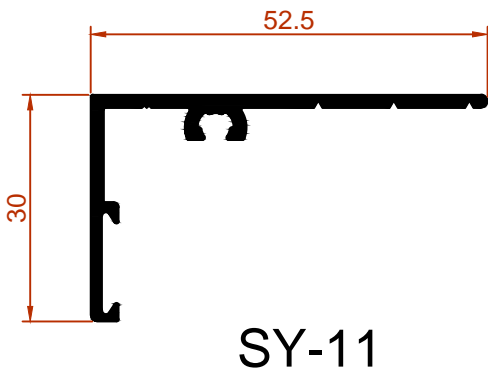
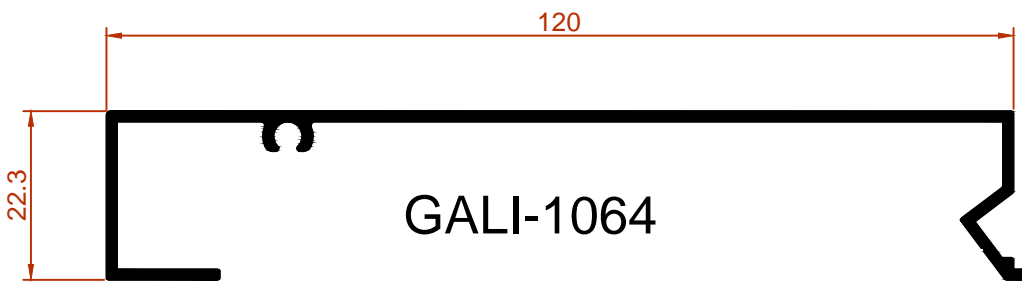
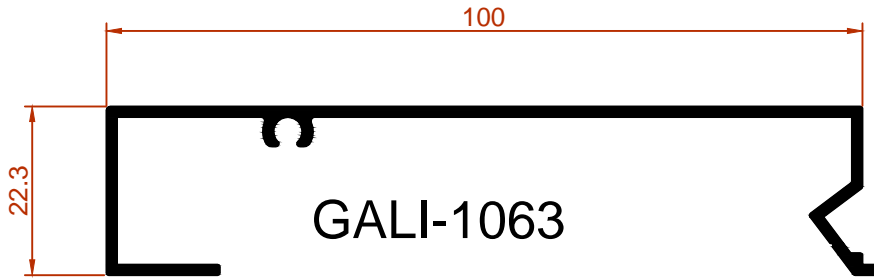

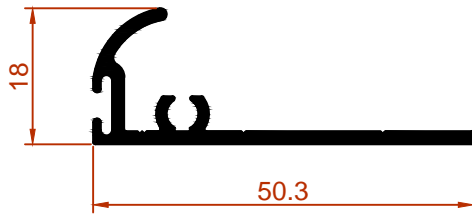

SY-21

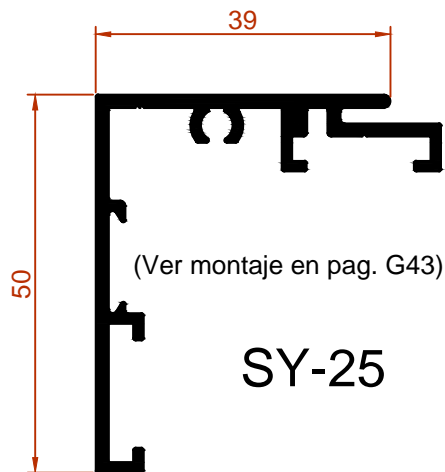

SY-25

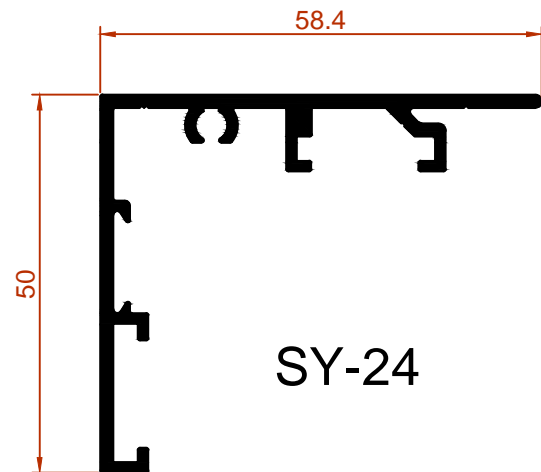

SY-24

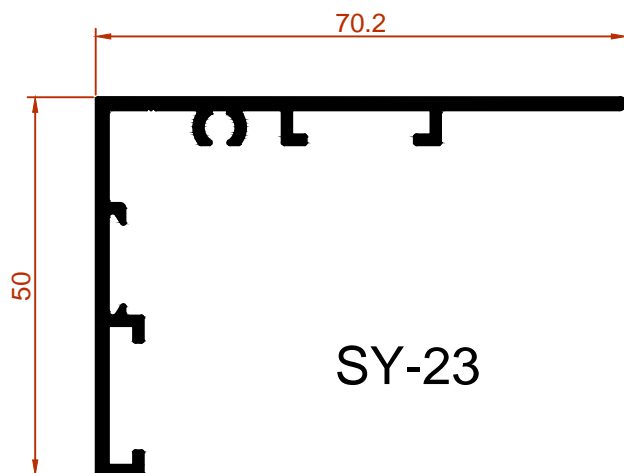

SY-23

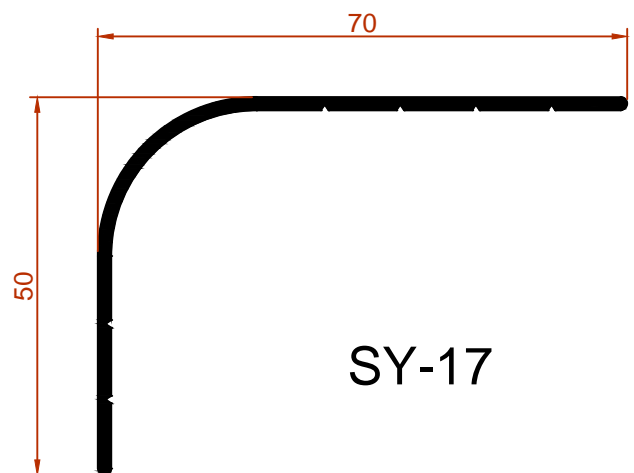

SY-17

Perfiles escala 1:1

RT74 CE - D15

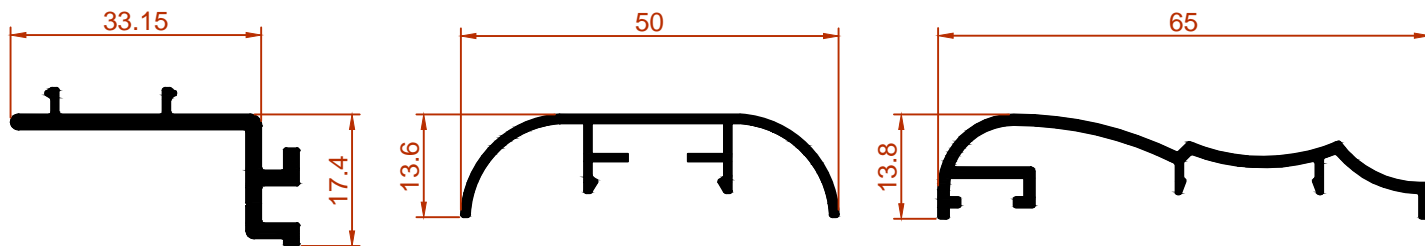

Gali-1006

GALI-1007

GALI-1078

(Ver montaje en pag. G42)

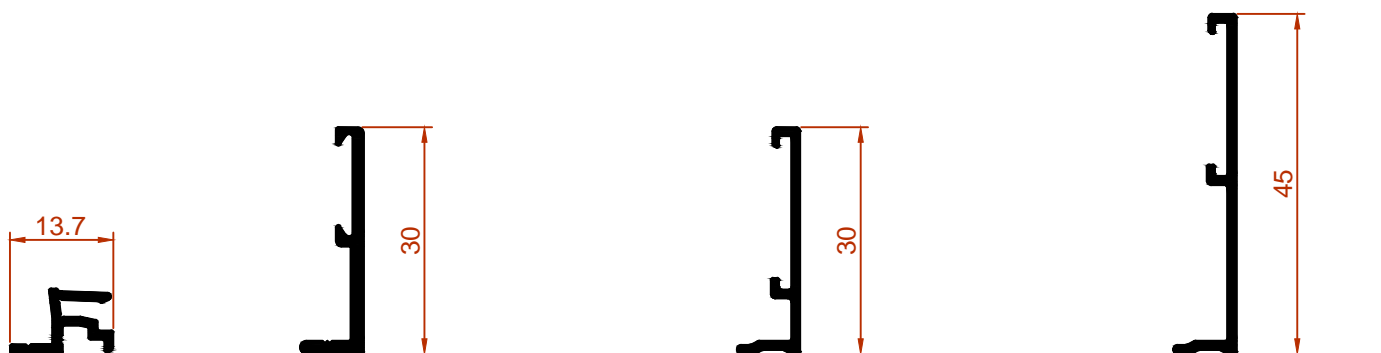

SY-26

SY-01

GALI-1116V

GALI-1118V

(Ver montaje en pag. G40 y siguientes)

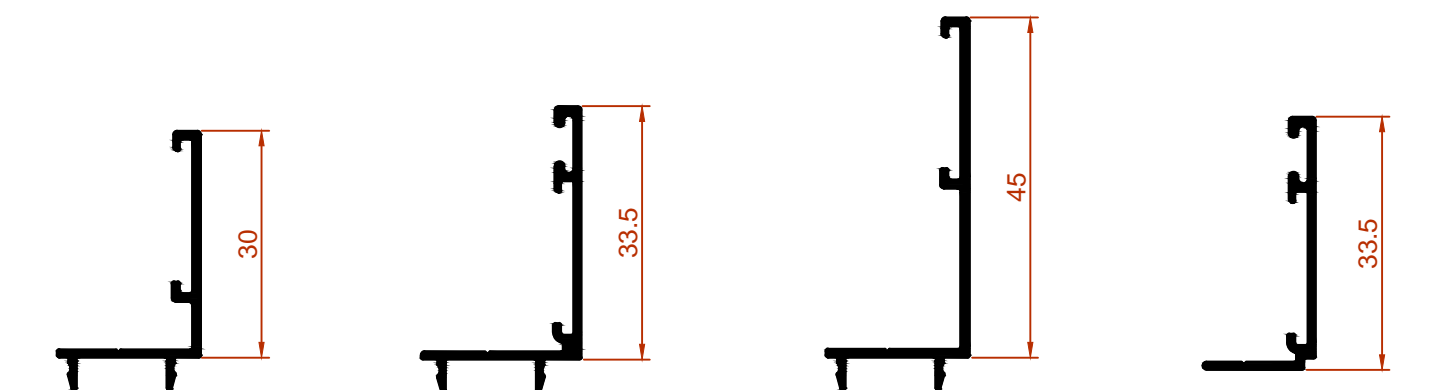

GALI-1115V

GALI-1085M

GALI-1117V

GALI-1086M

(Ver montaje en pag. G45)

Perfiles escala 1:1

RT74 CE - D16

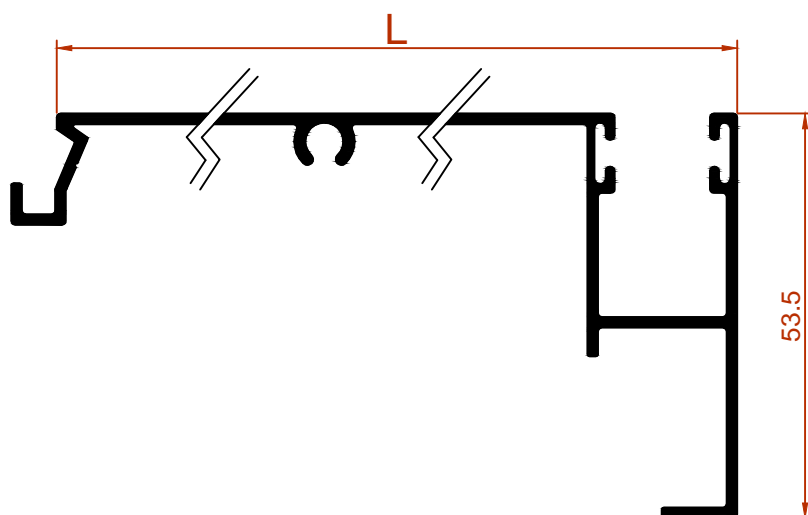
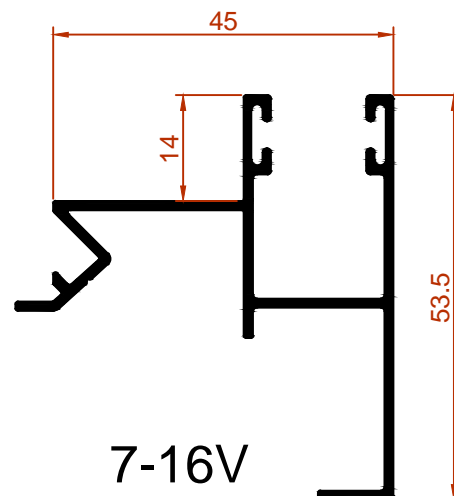
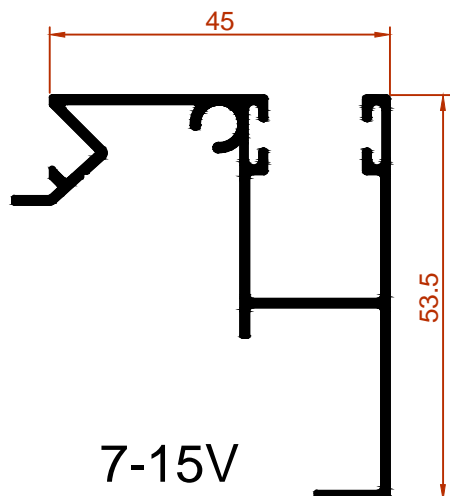

Referencia	Cota L
7-06	60
7-14	64,3
7-13	70
7-08	75
7-11	80

Referencia	Cota L
7-10	90
7-09	95
7-05	104
7-12	120

Perfiles escala 1:1

RT74 CE - D17

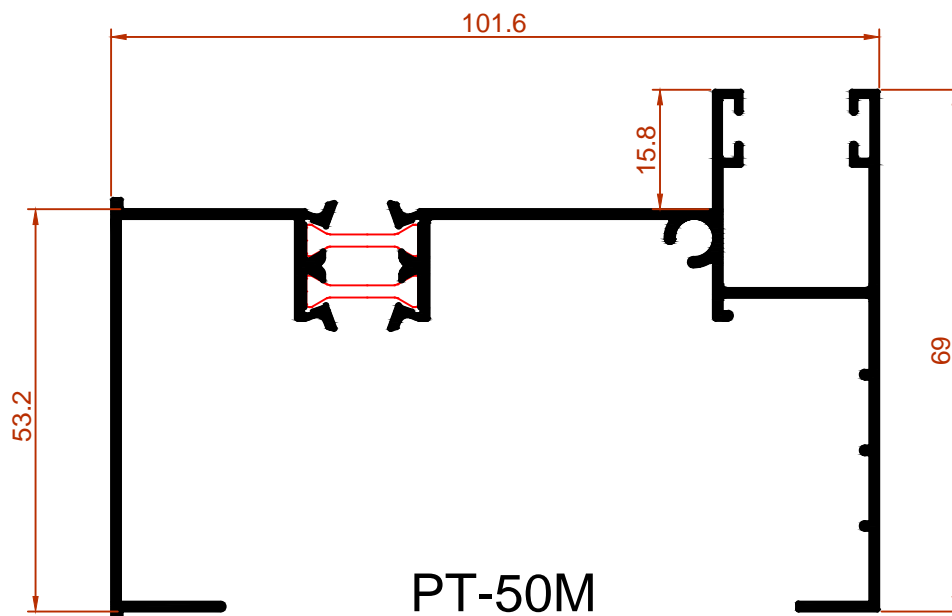
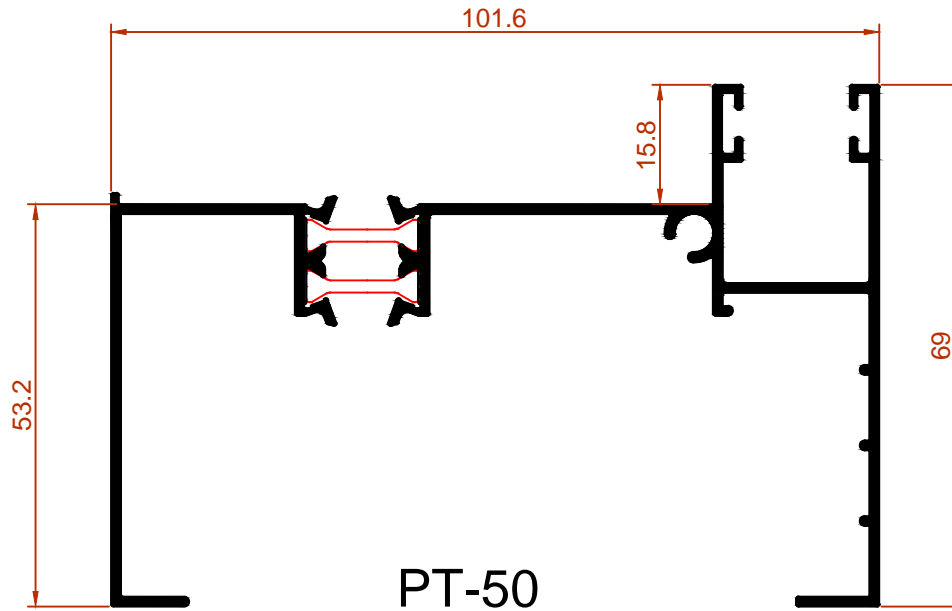

Perfiles escala 1:1

RT74 CE - D18

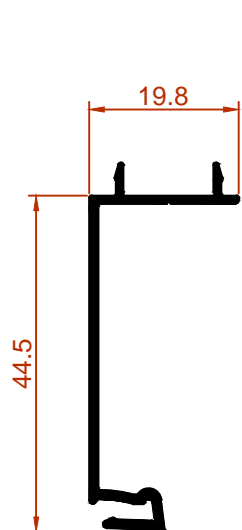

GALI-1120V

(Ver montaje en pag. G40 y siguientes)

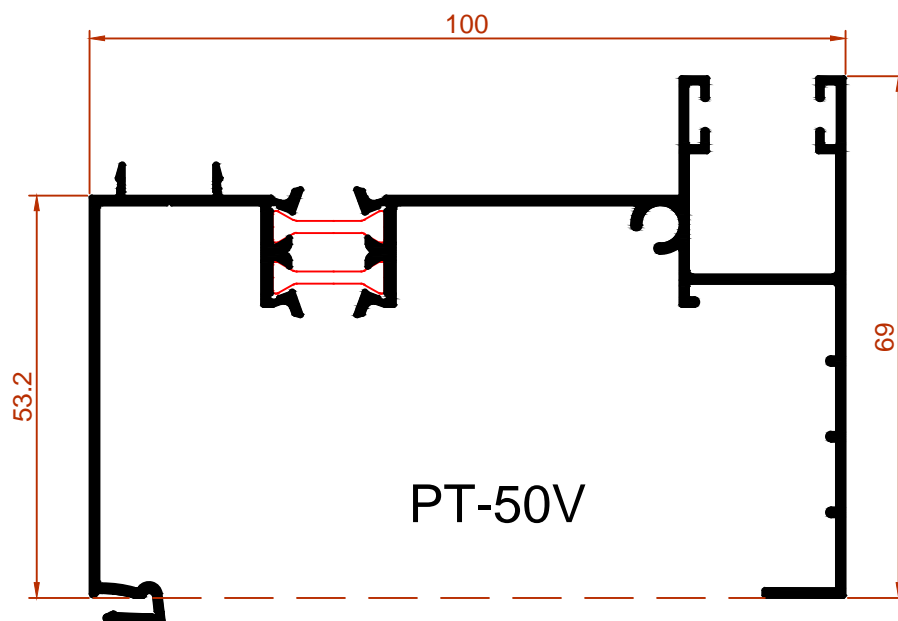

PT-50V

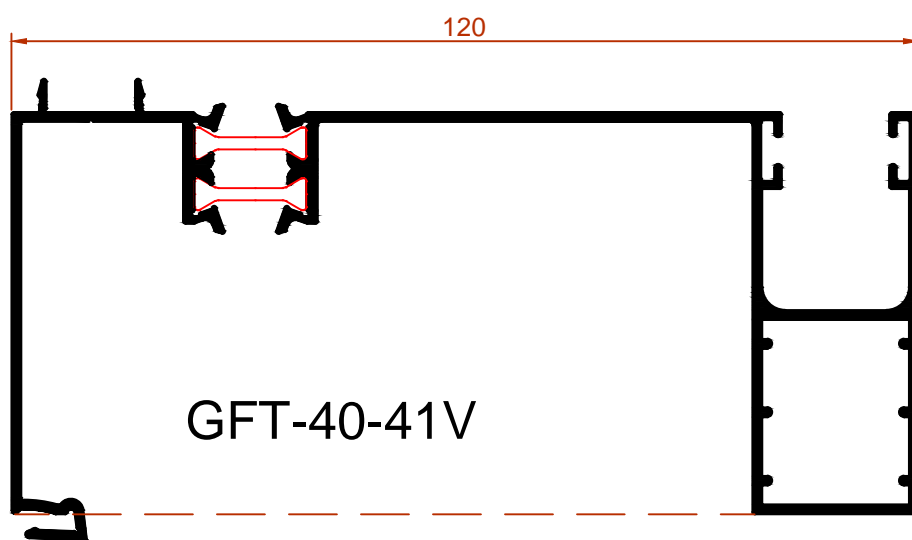

GFT-40-41V

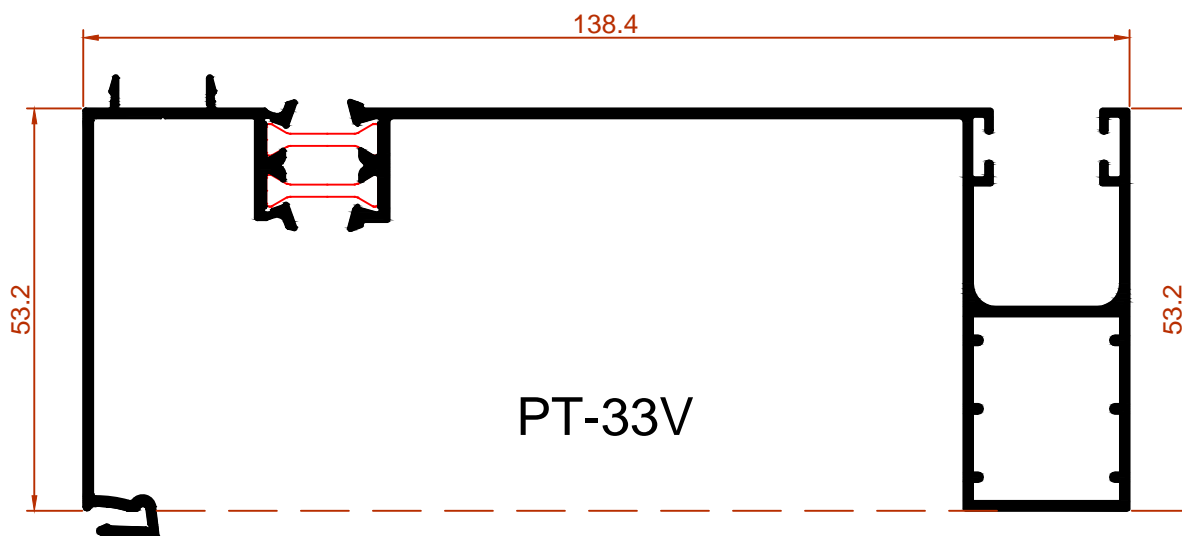

PT-33V

APERTURA INTERIOR

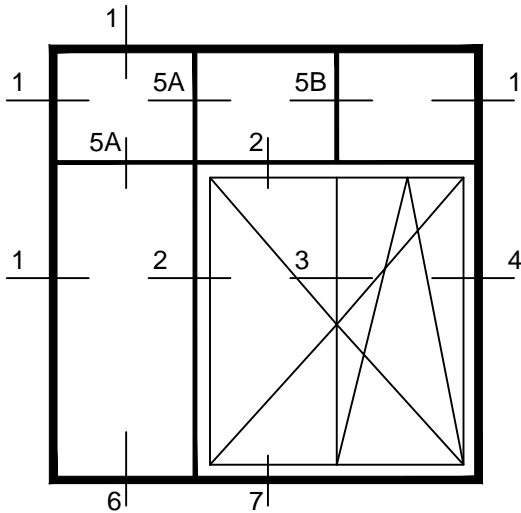

Ventanas

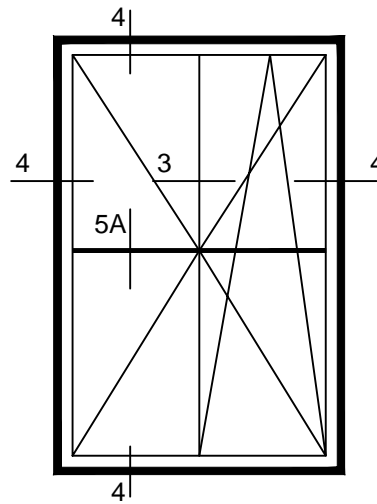

Balconera

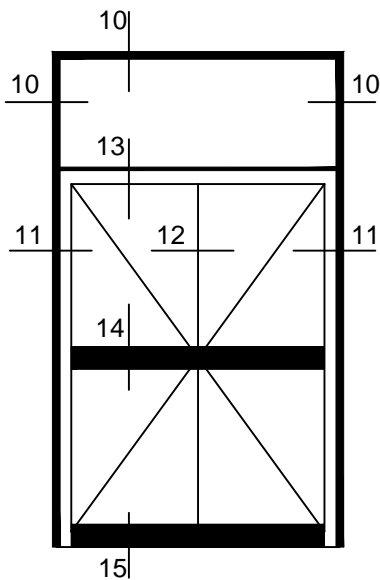

Puerta entrada

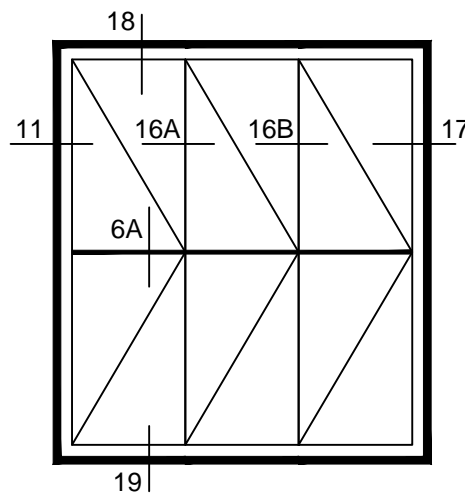

Plegable

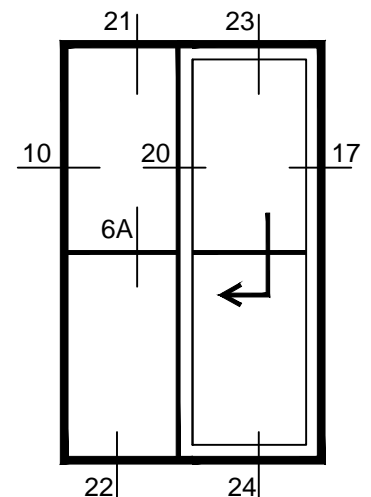

Osciloparalela

Secciones tipo

GUÍA

RT74 CE - G2

APERTURA EXTERIOR

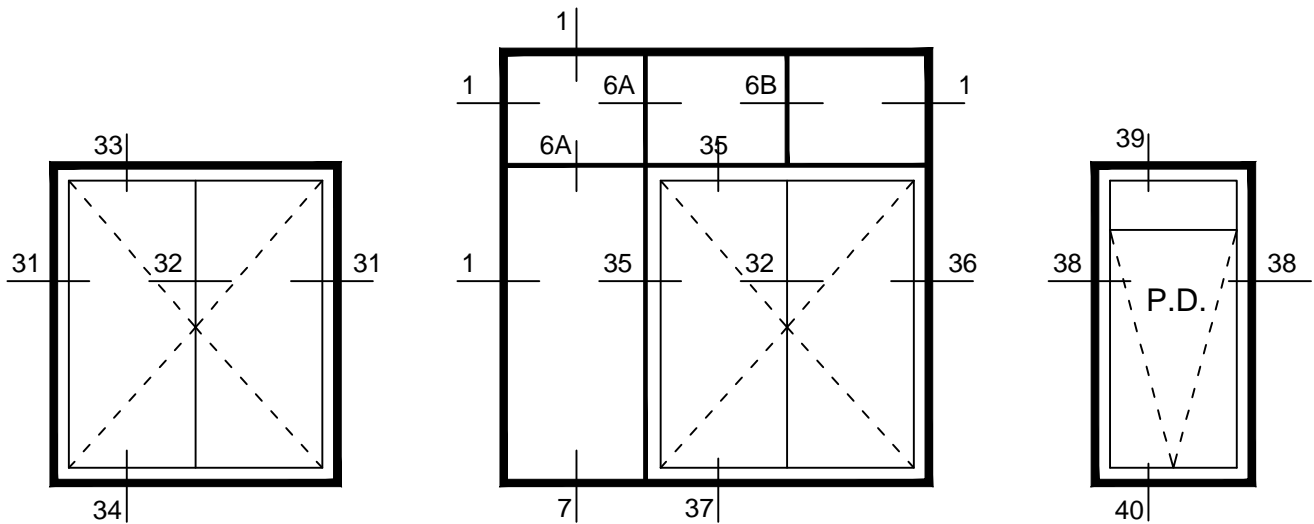

Ventanas

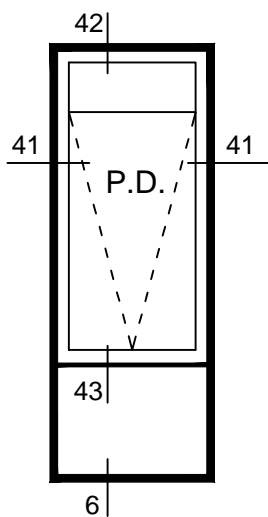

Proyectante-
deslizante

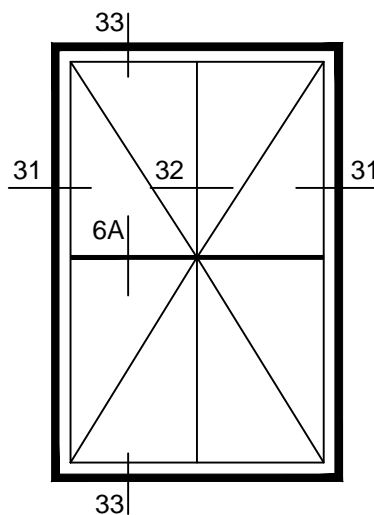

Balconera

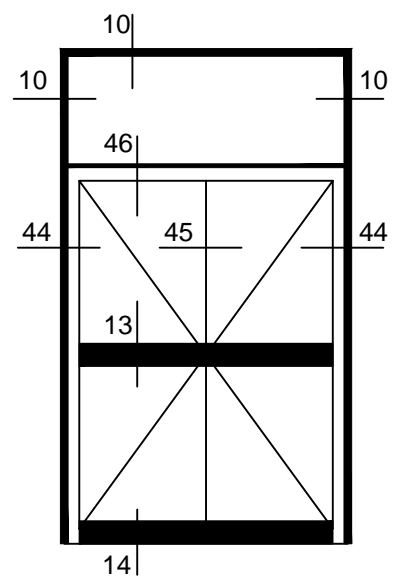

Puerta entrada

Secciones tipo

RT74 CE - G3

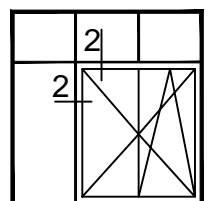
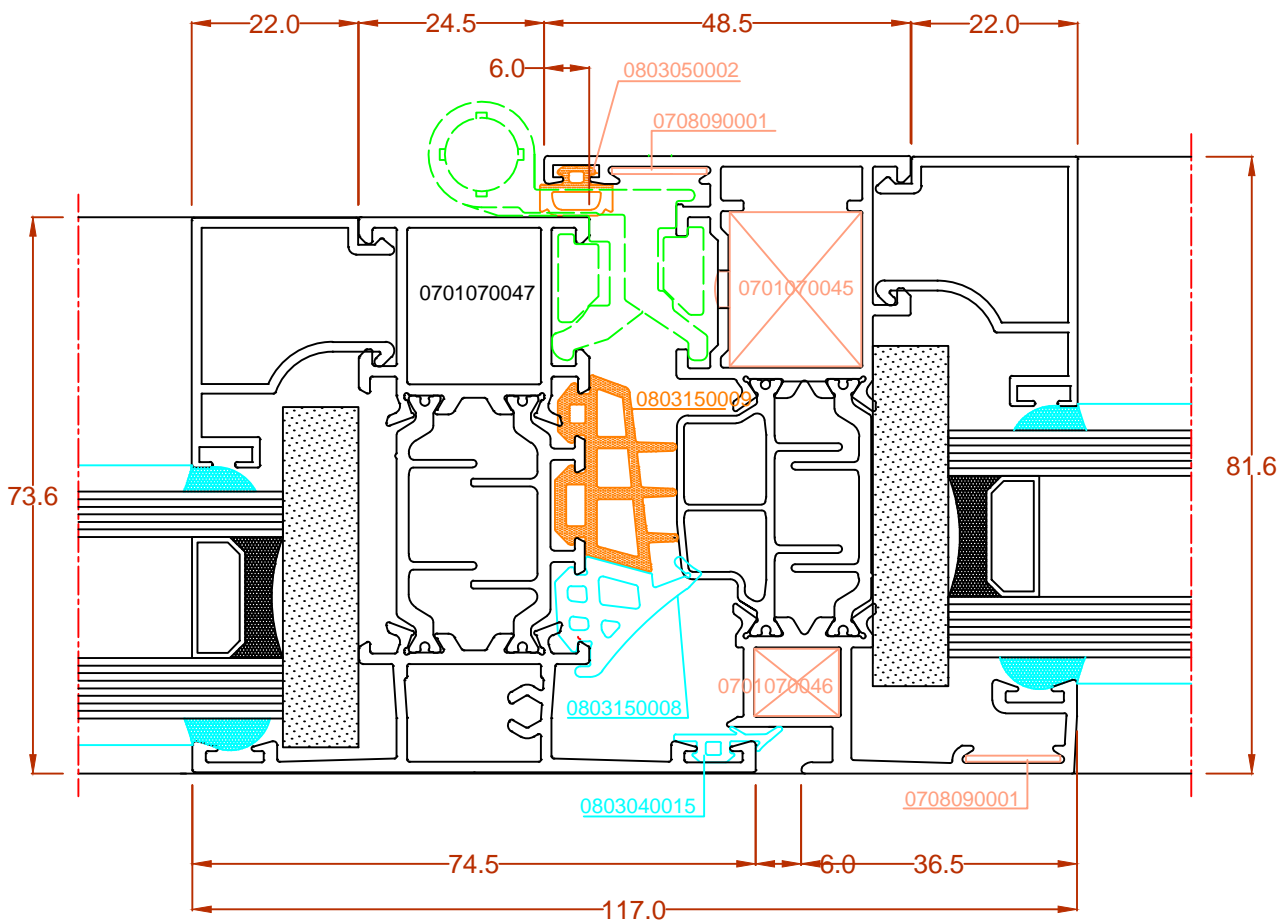
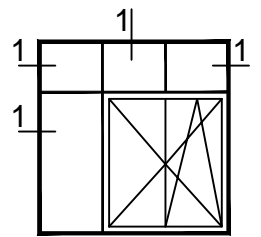
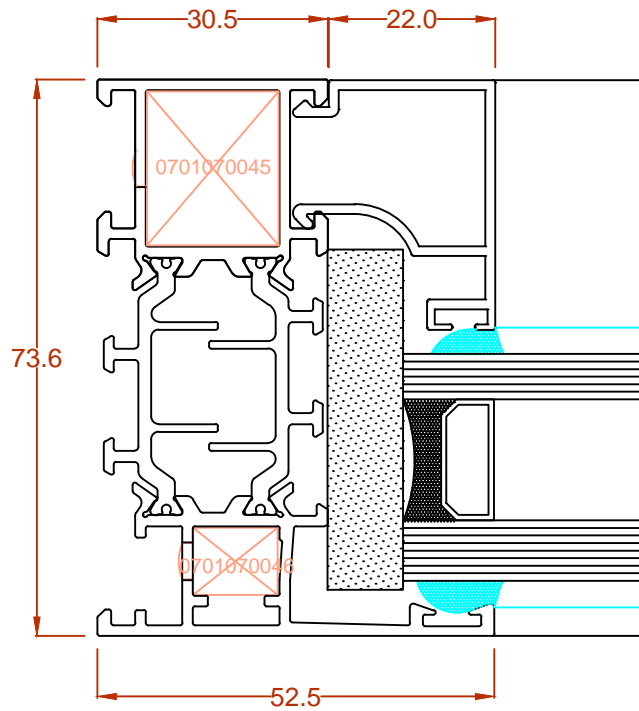

Secciones tipo

RT74 CE - G4

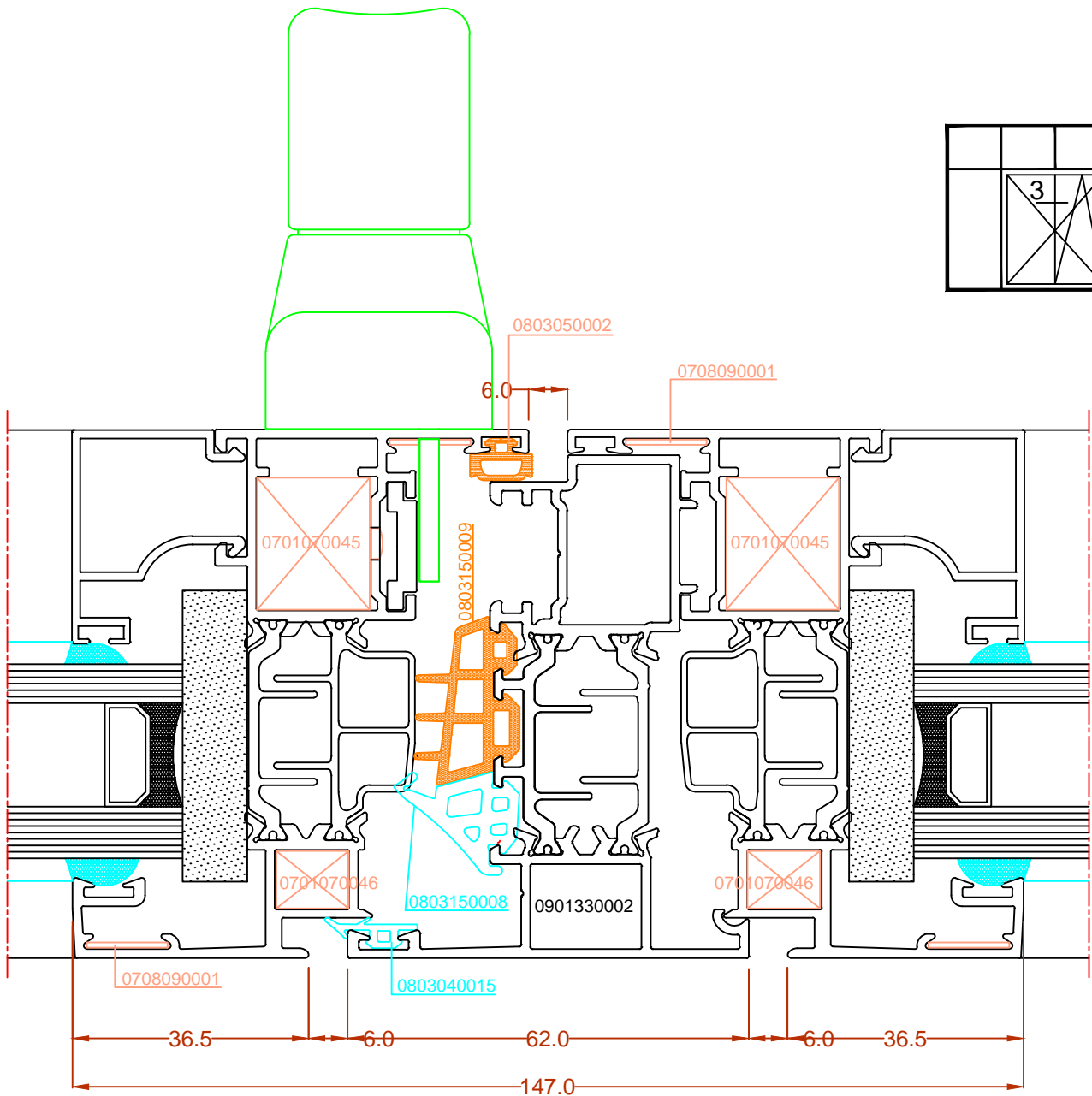

Secciones tipo

RT74 CE - G5

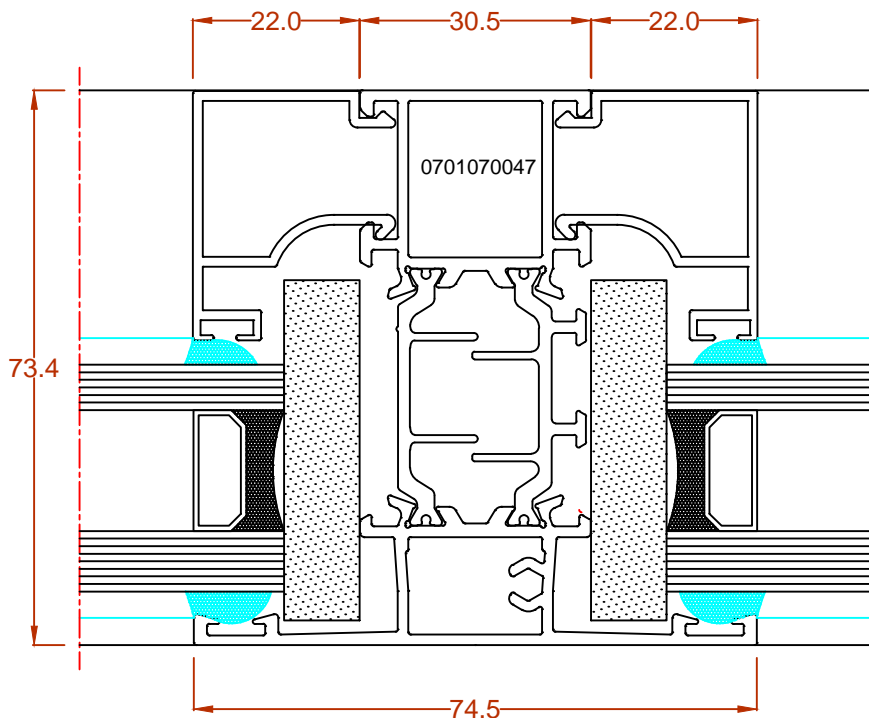
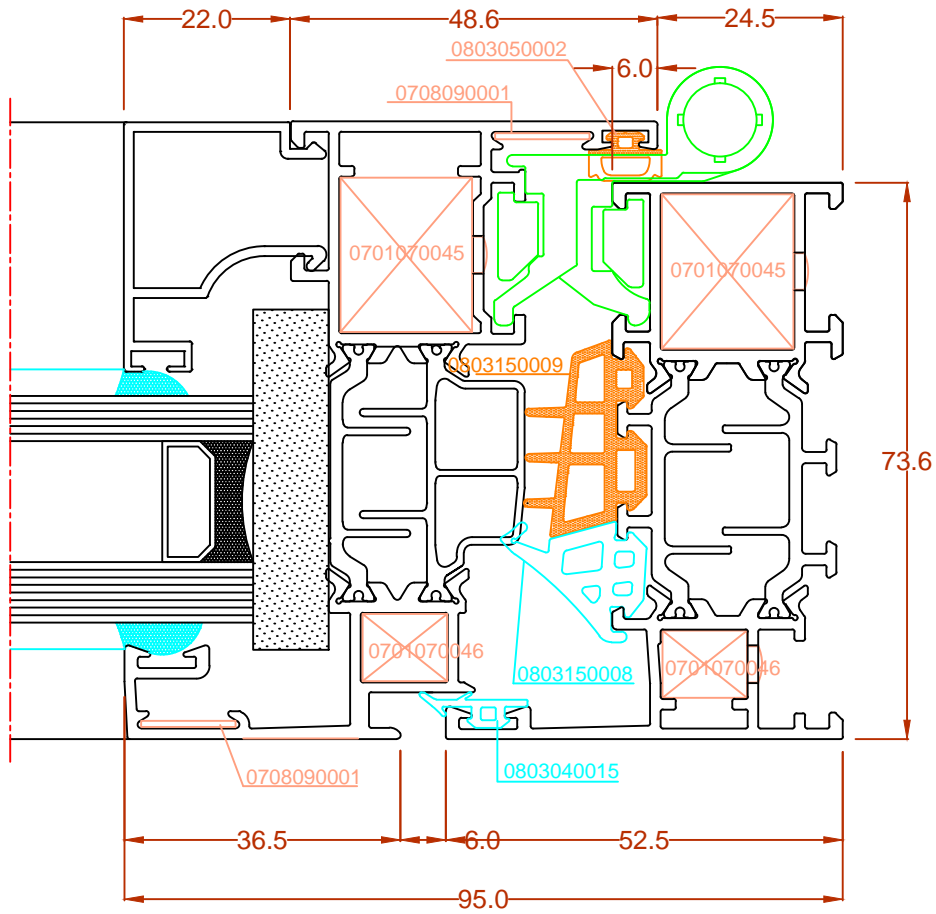

Secciones tipo

RT74 CE - G6

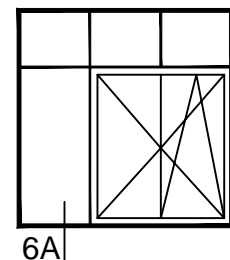
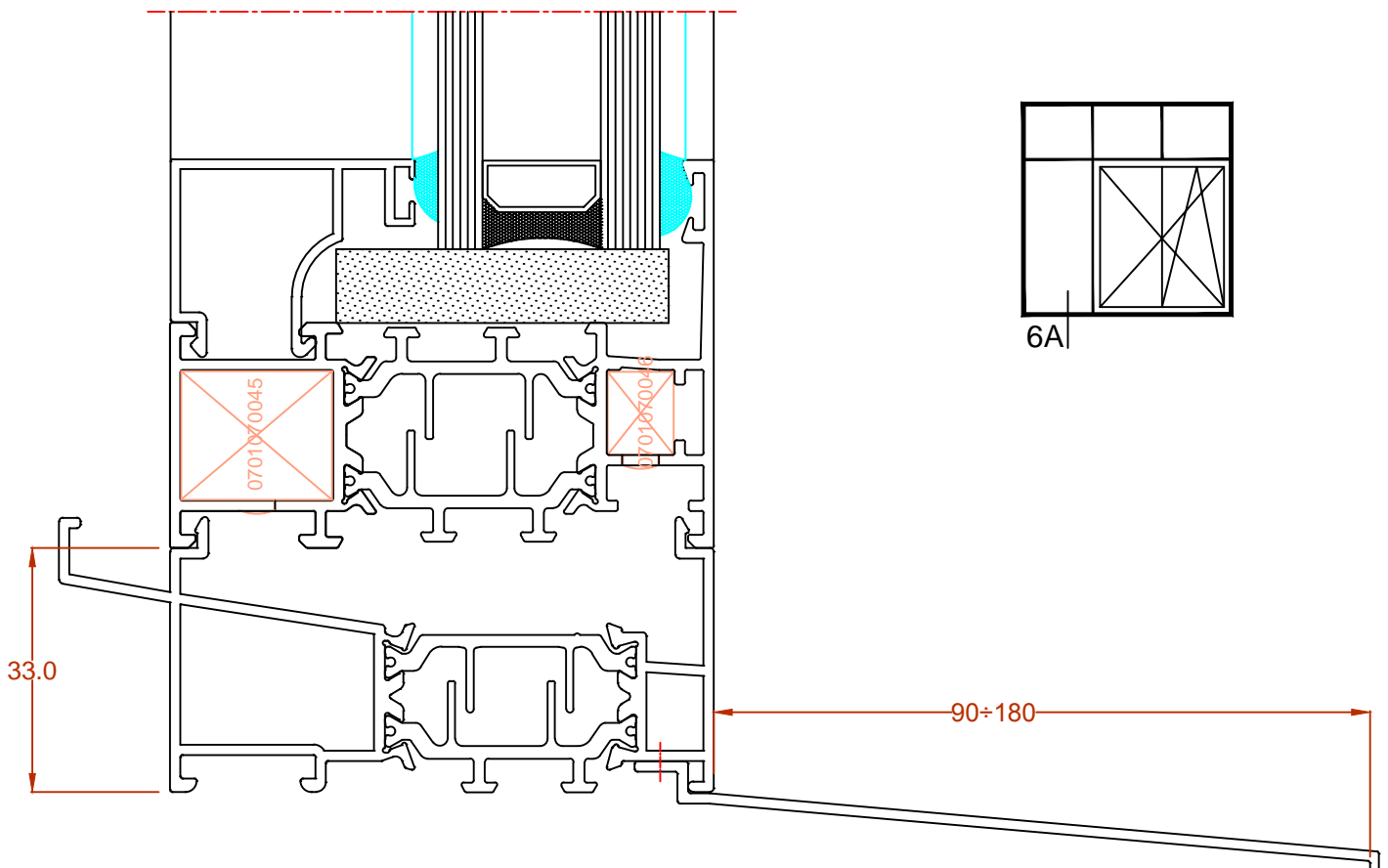
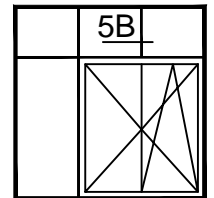
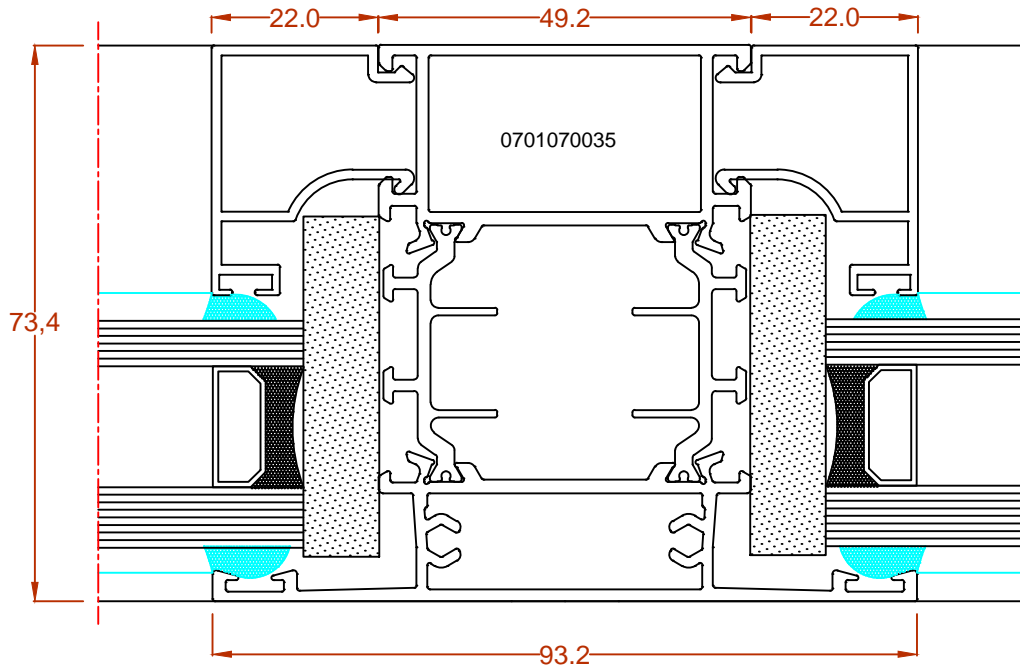

Secciones tipo

RT74 CE - G7

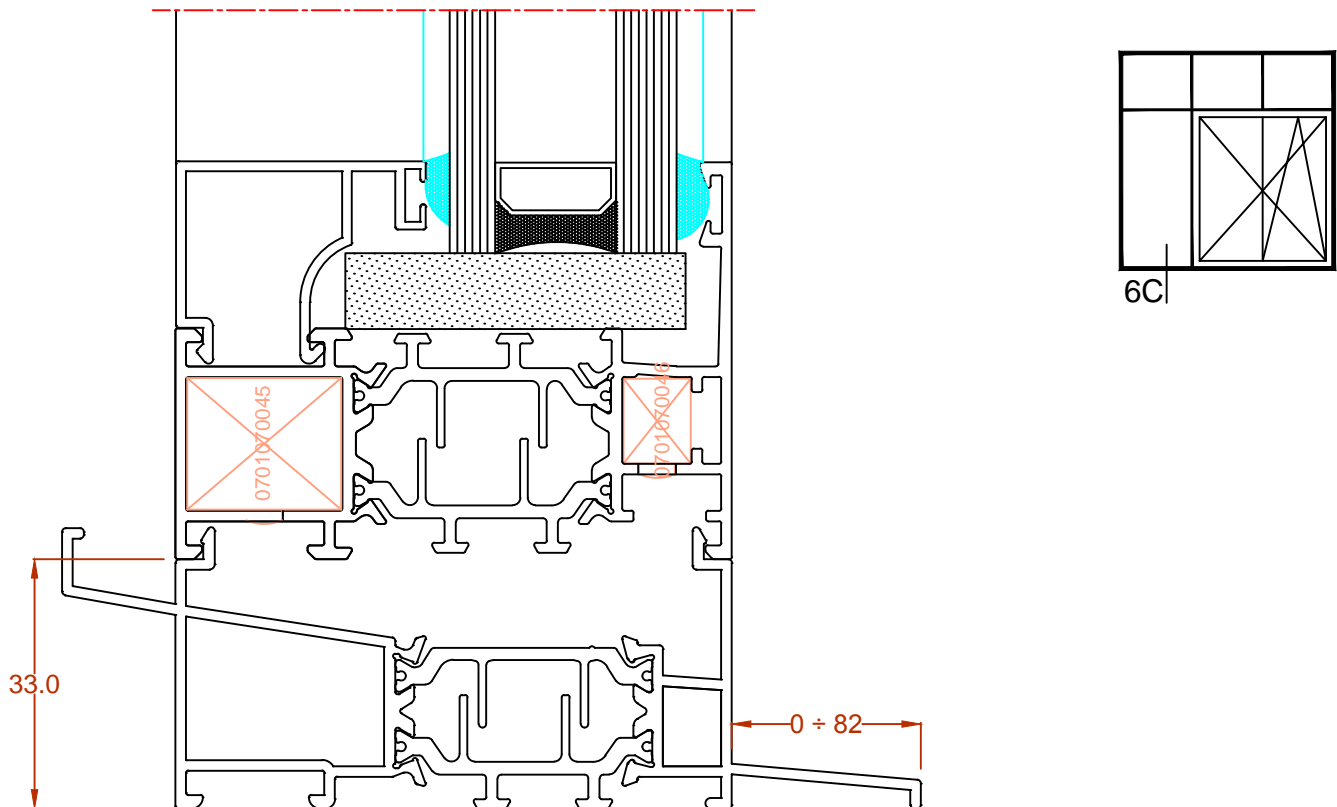
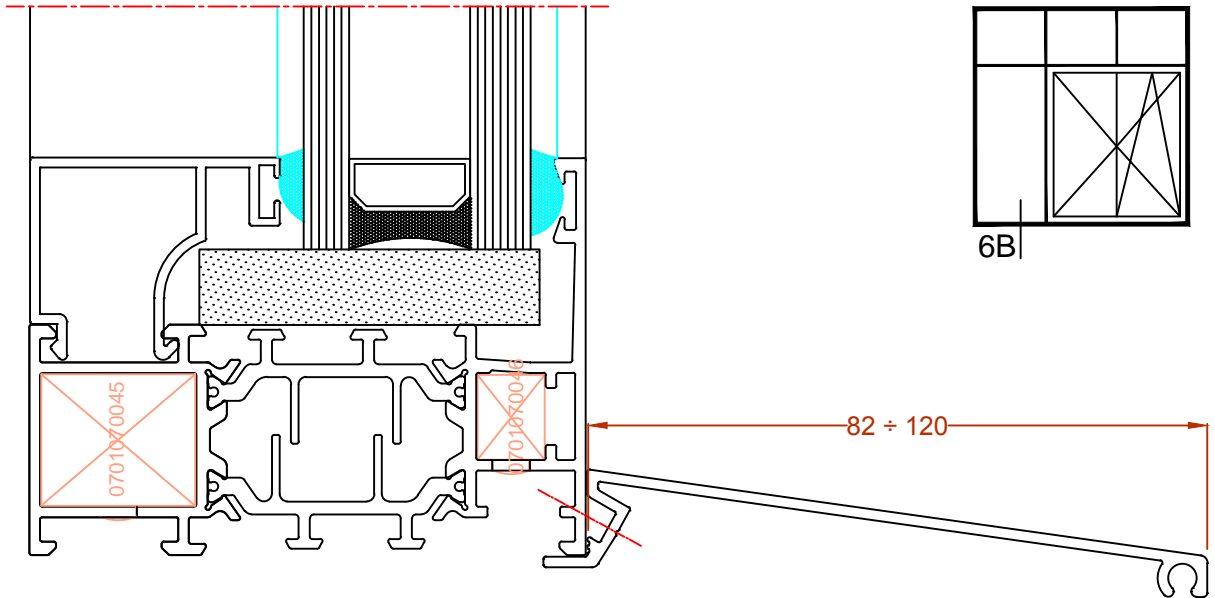

Secciones tipo

RT74 CE - G8

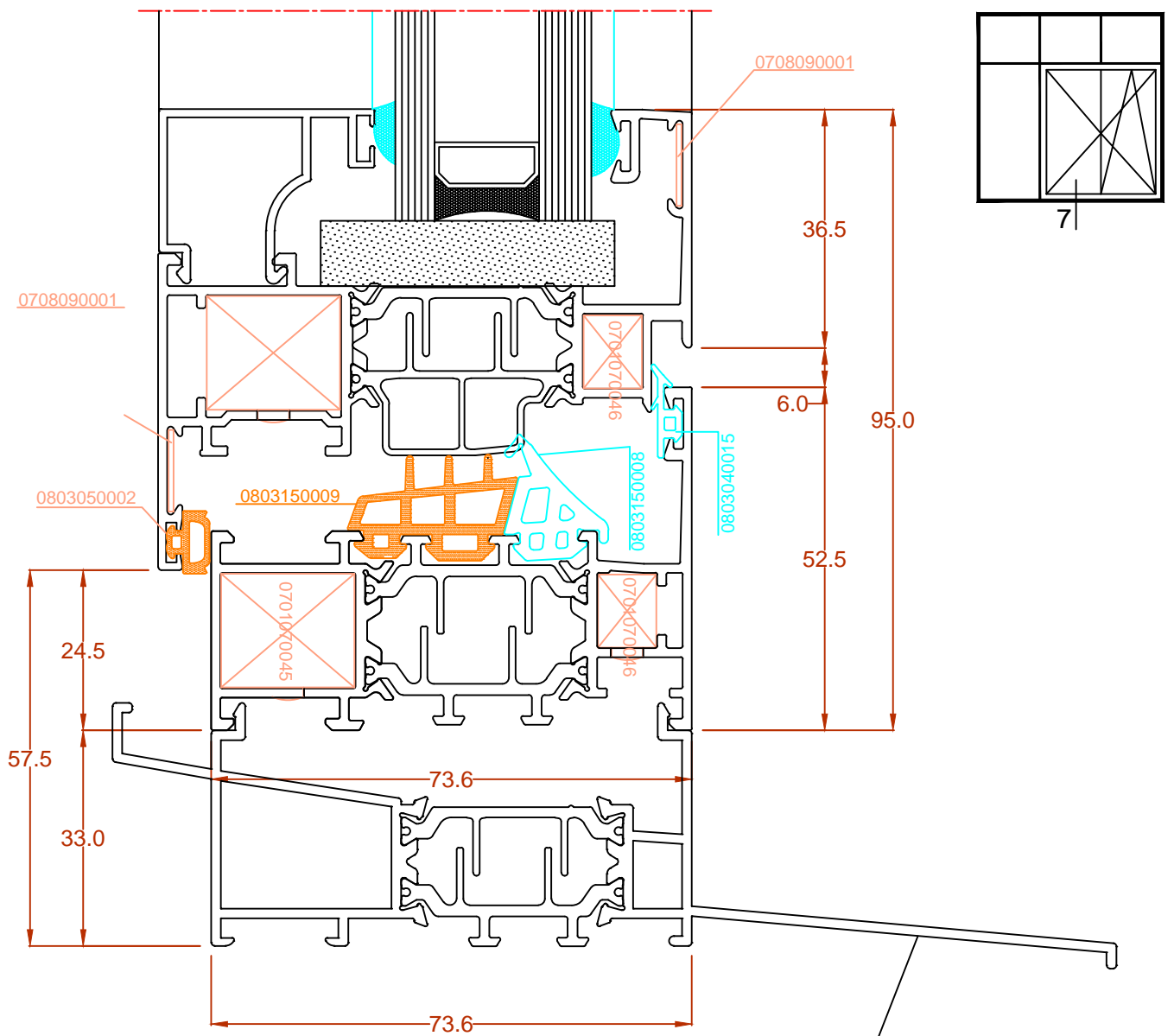

Ver alternativas en Secciones 6A, 6B, 6C

Secciones tipo

RT74 CE - G9

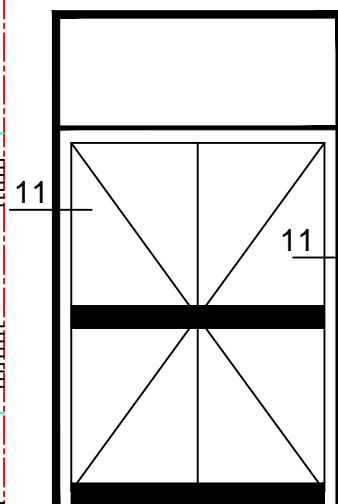
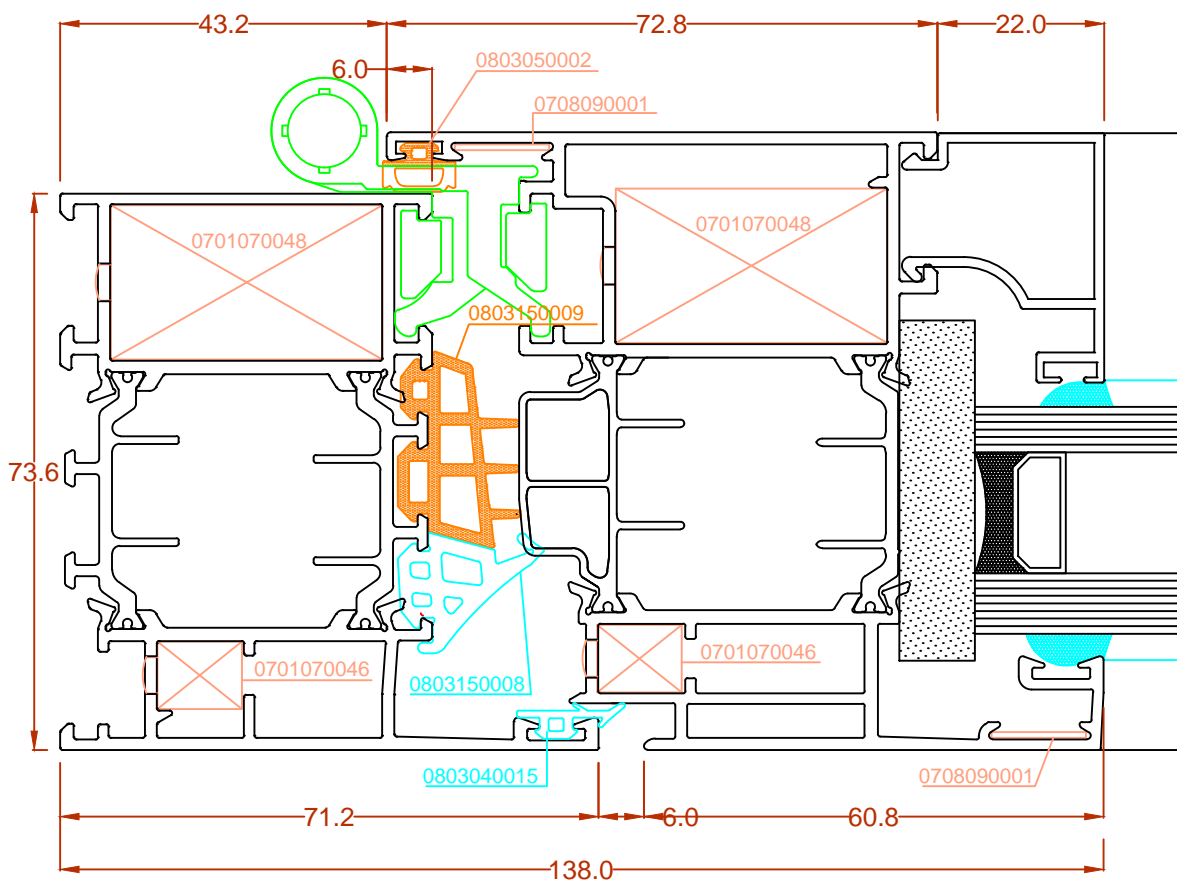
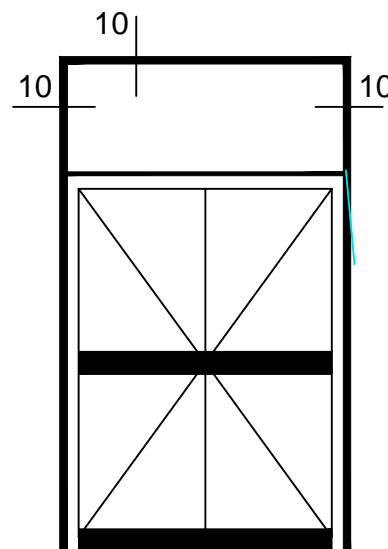
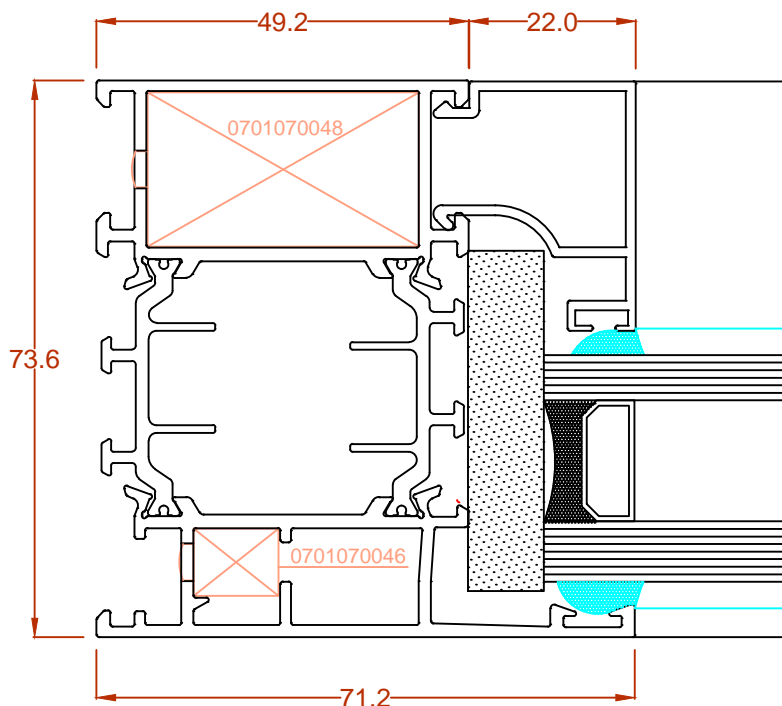

Secciones tipo

RT74 CE - G12

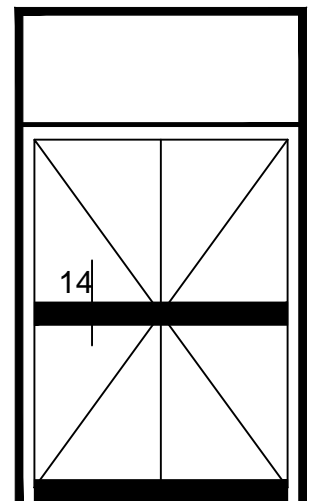
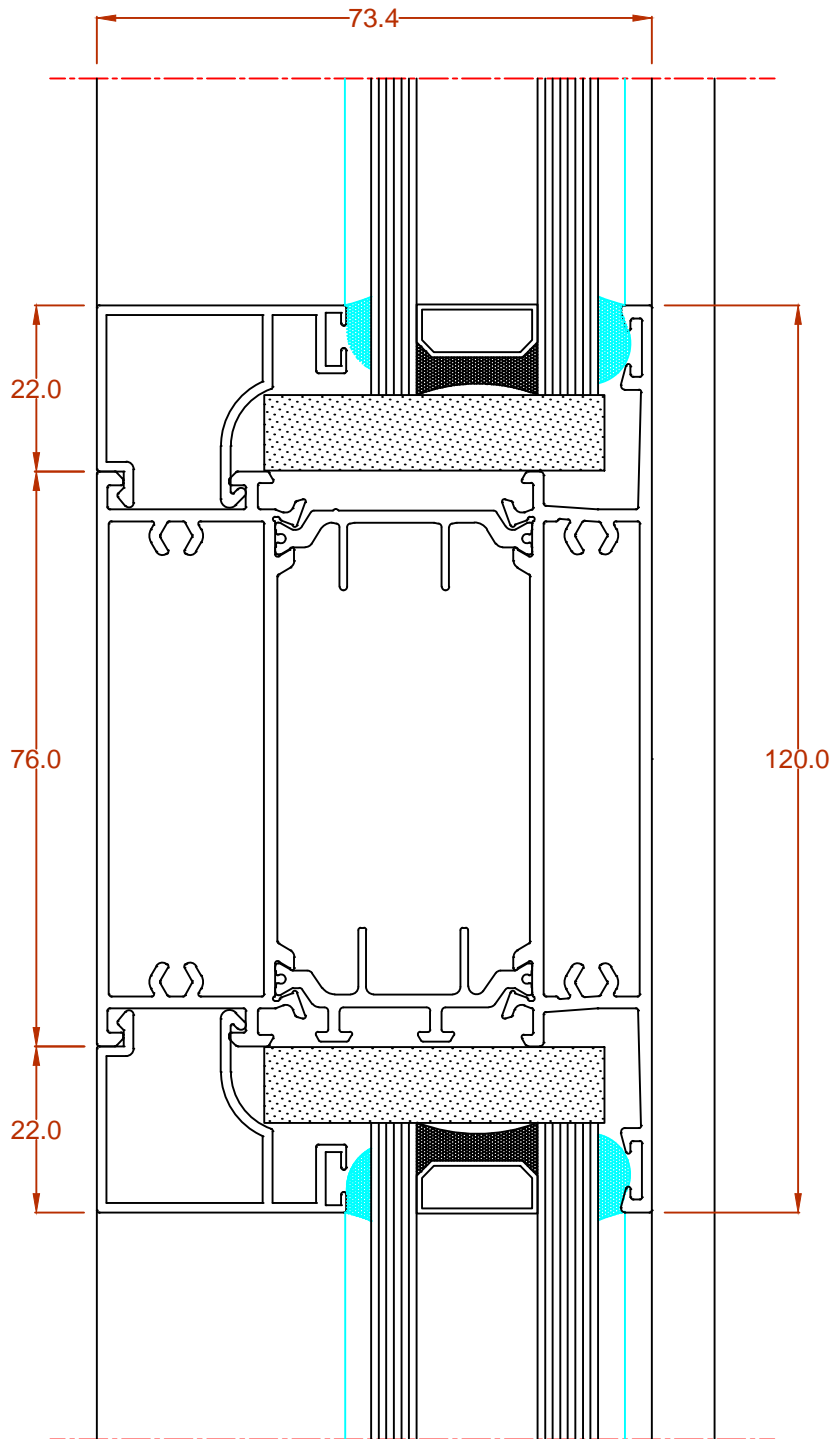

Secciones tipo

RT74 CE - G13

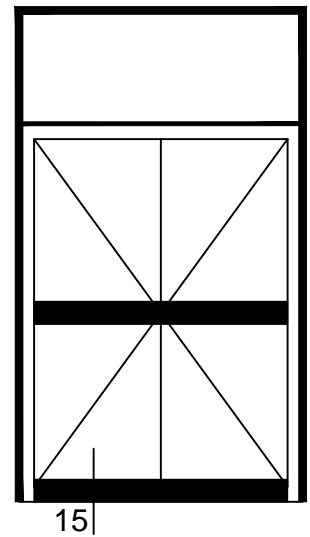
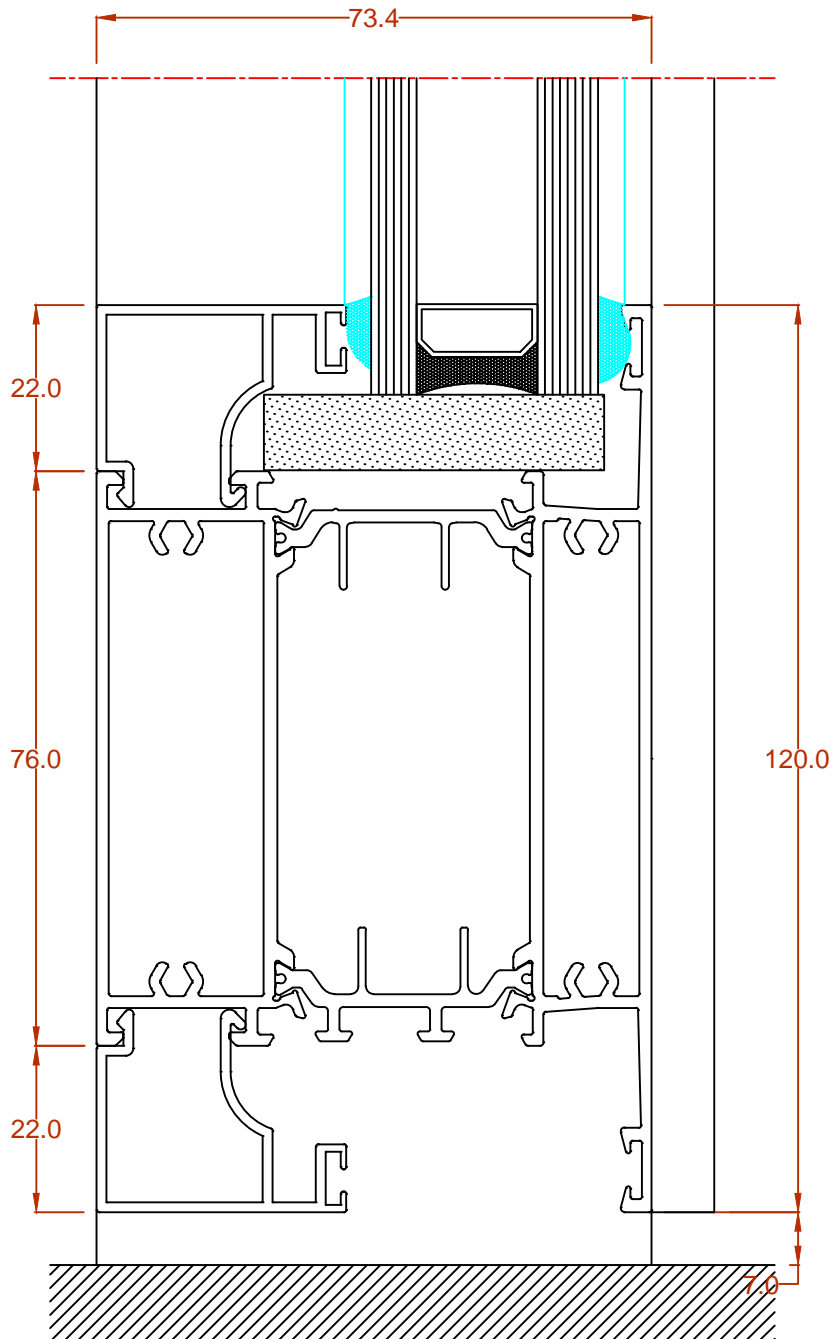

Secciones tipo

RT74 CE - G15

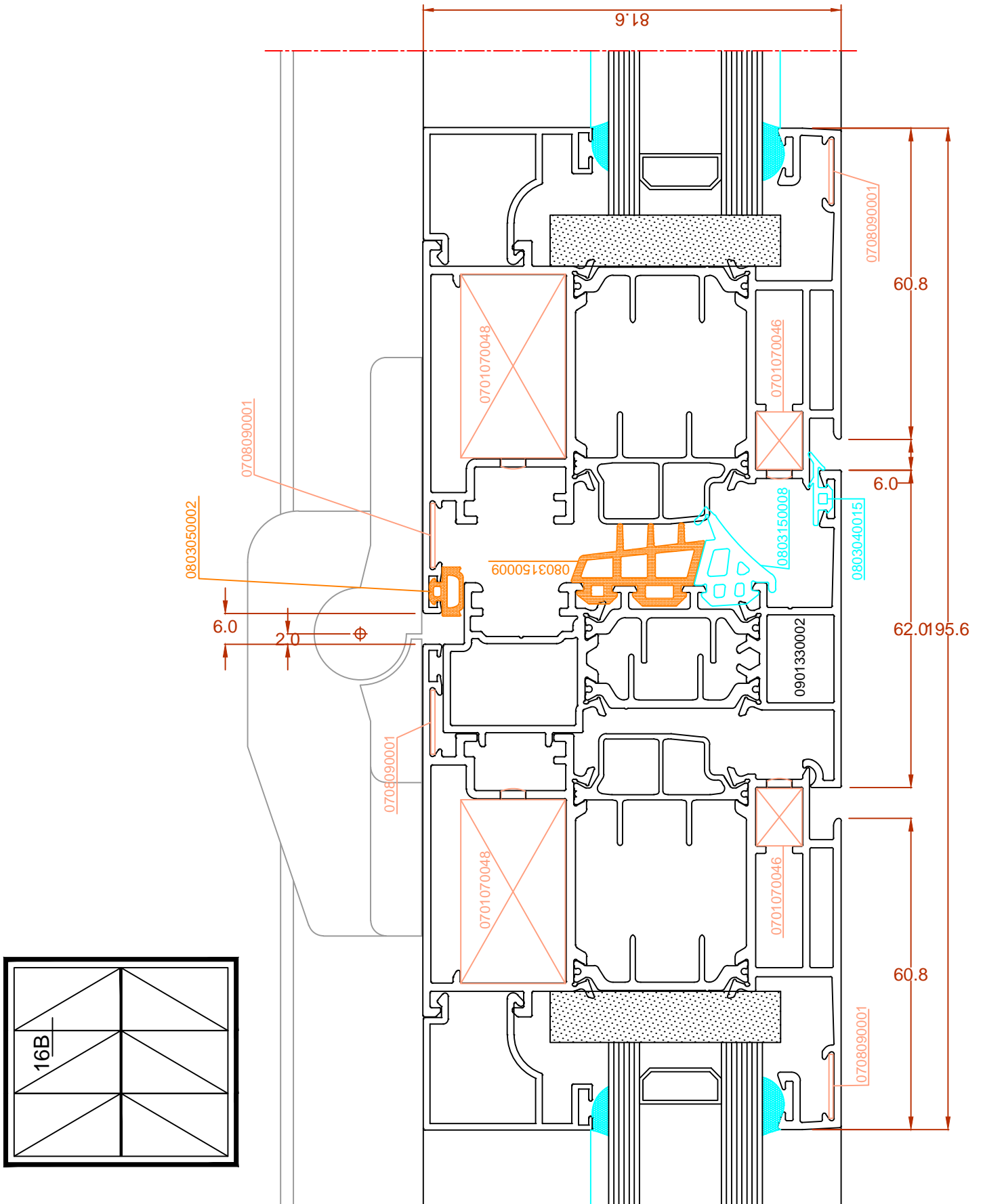

Secciones tipo

RT74 CE - G16

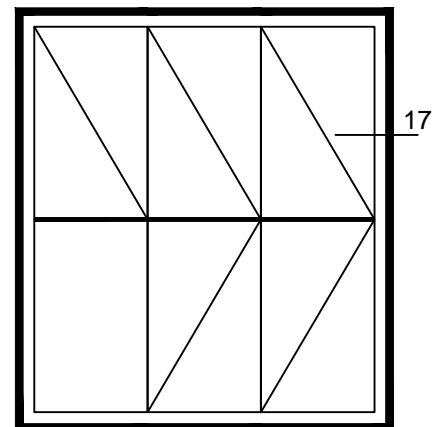
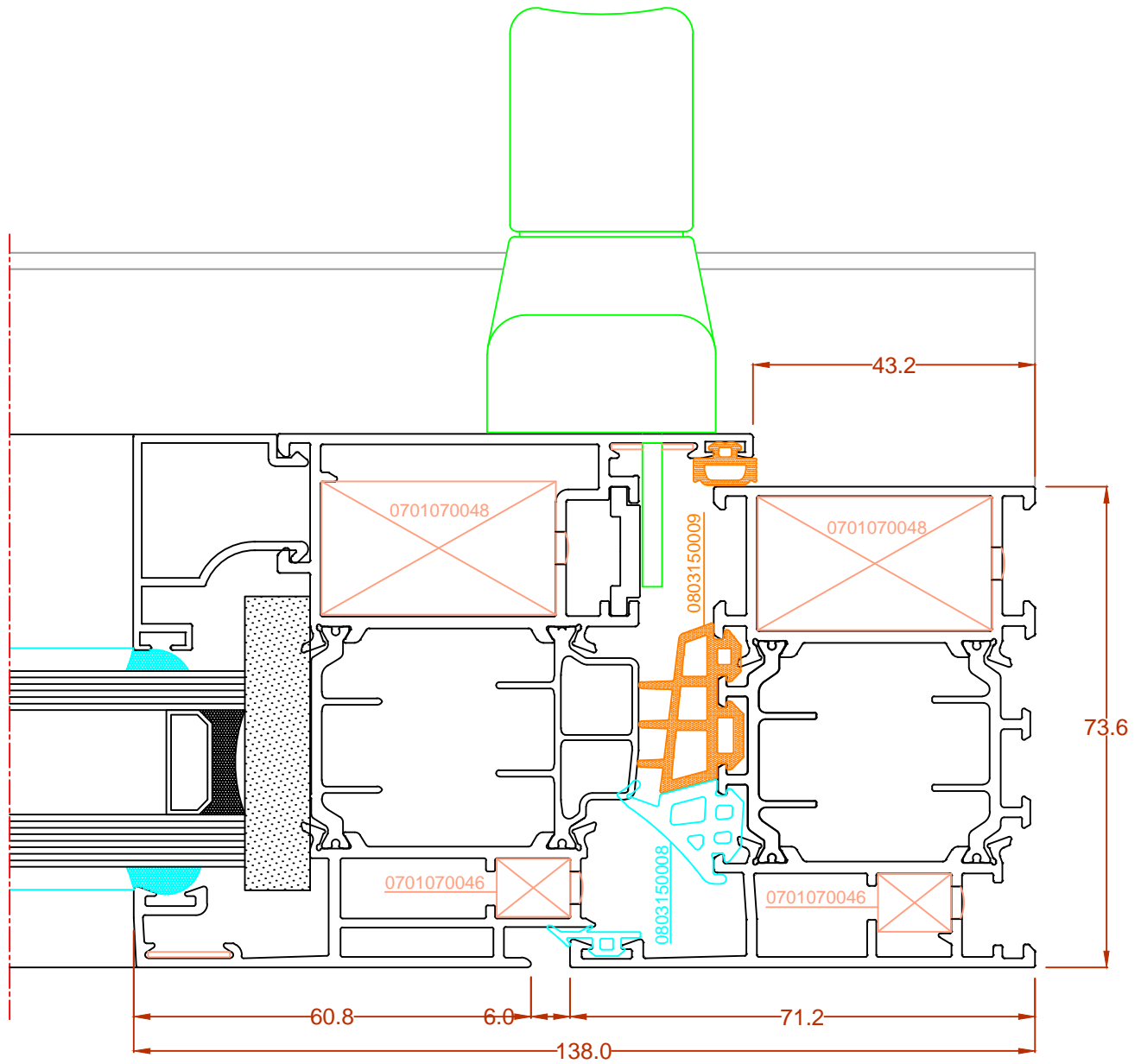

Secciones tipo

RT74 CE - G17

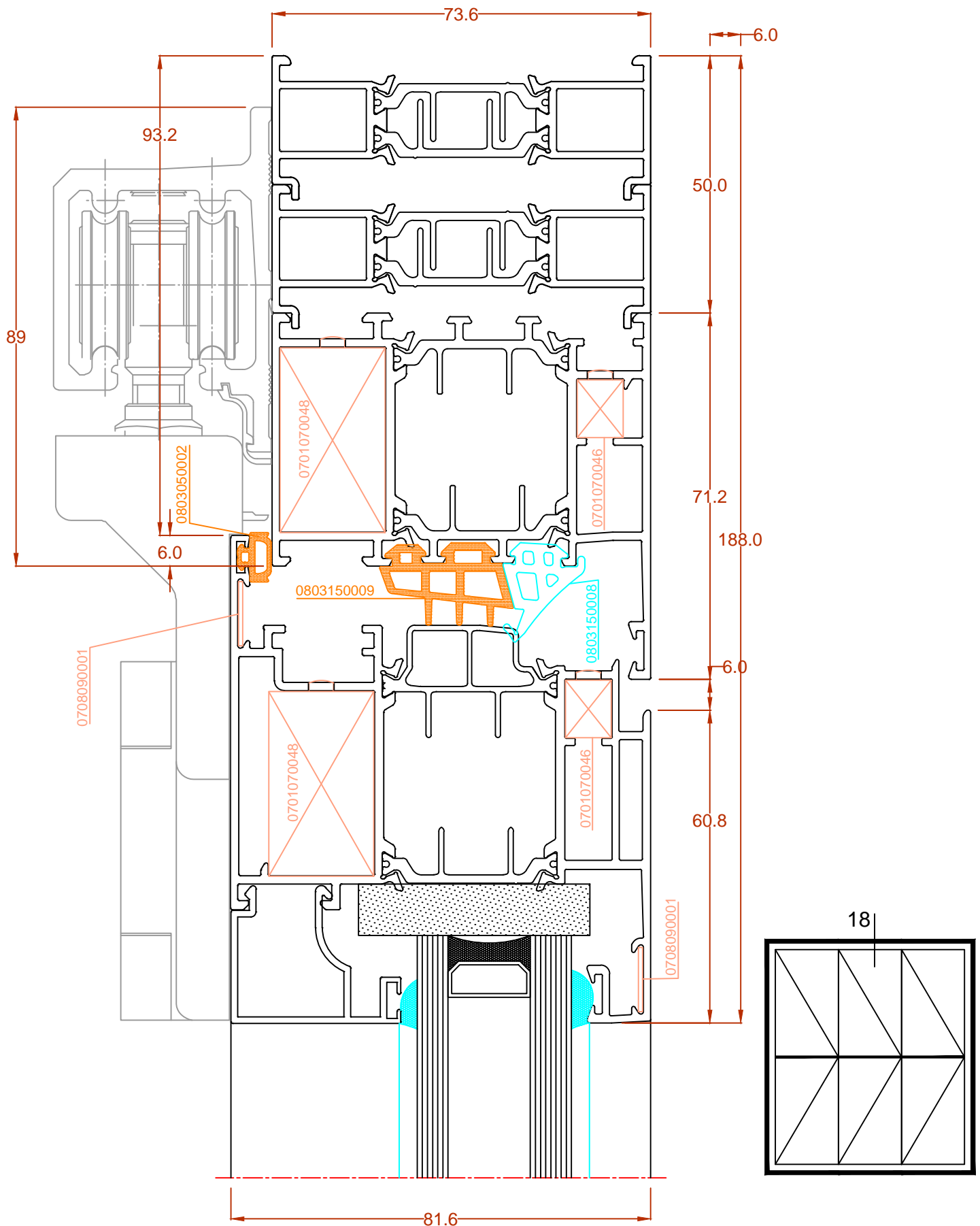

Secciones tipo

RT74 CE - G18

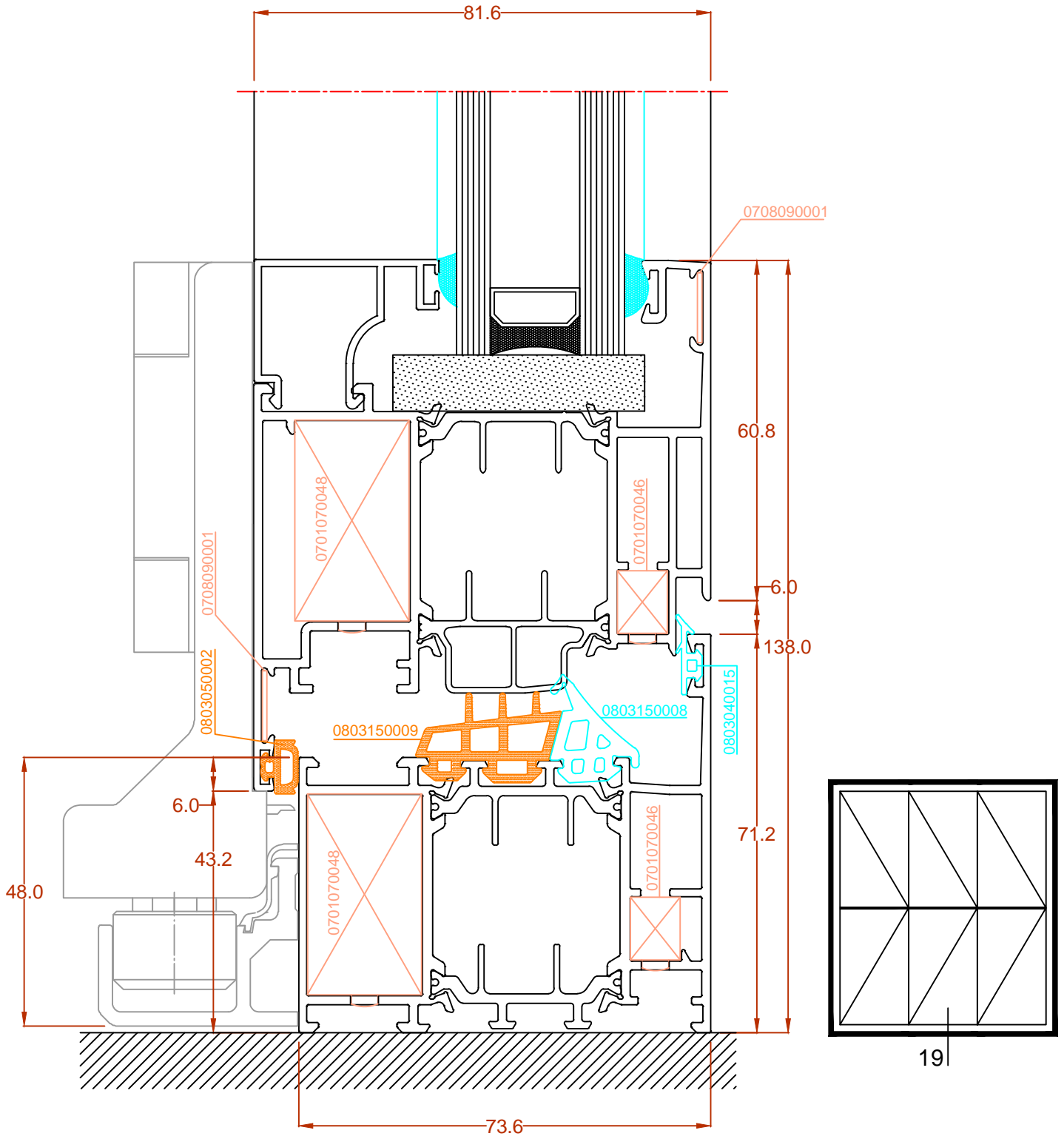

Secciones tipo

RT74 CE - G19

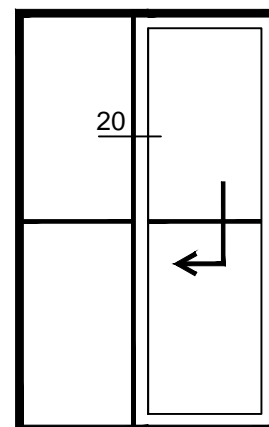
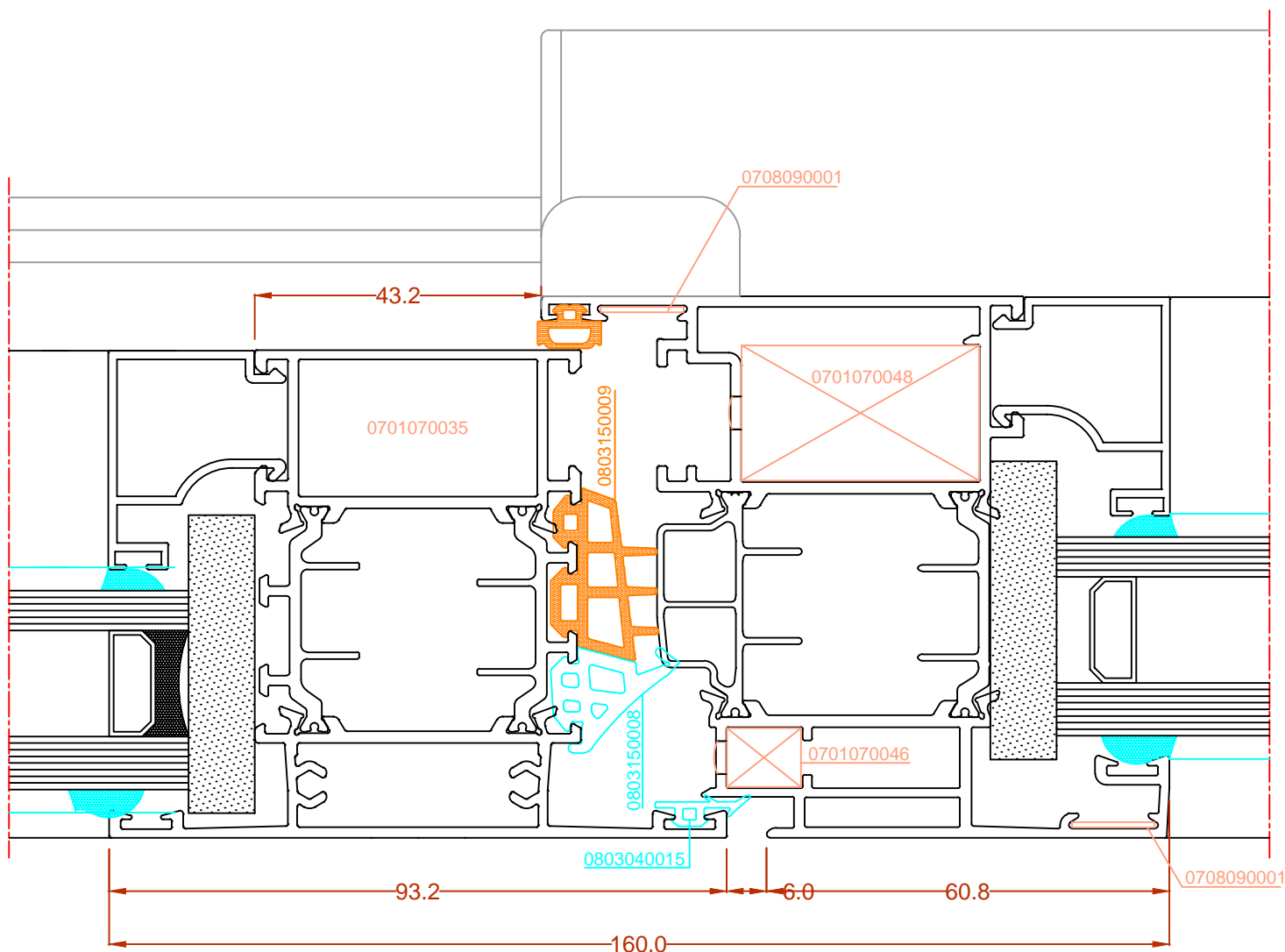

Secciones tipo

RT74 CE - G20

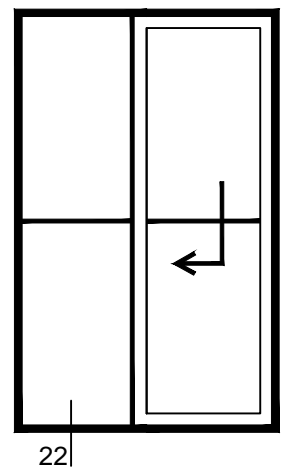
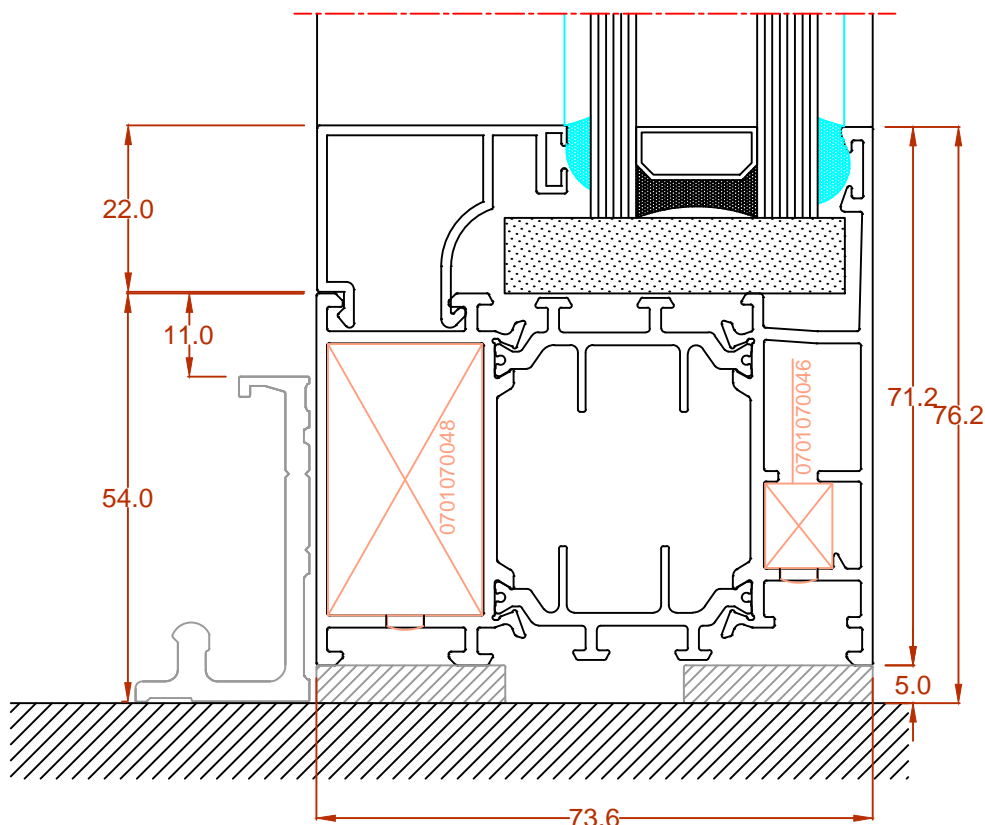
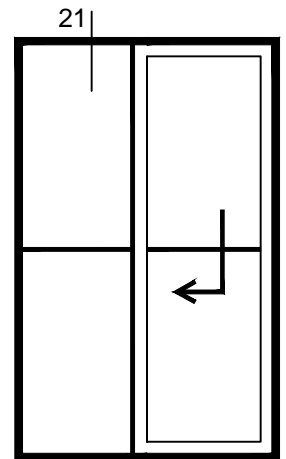
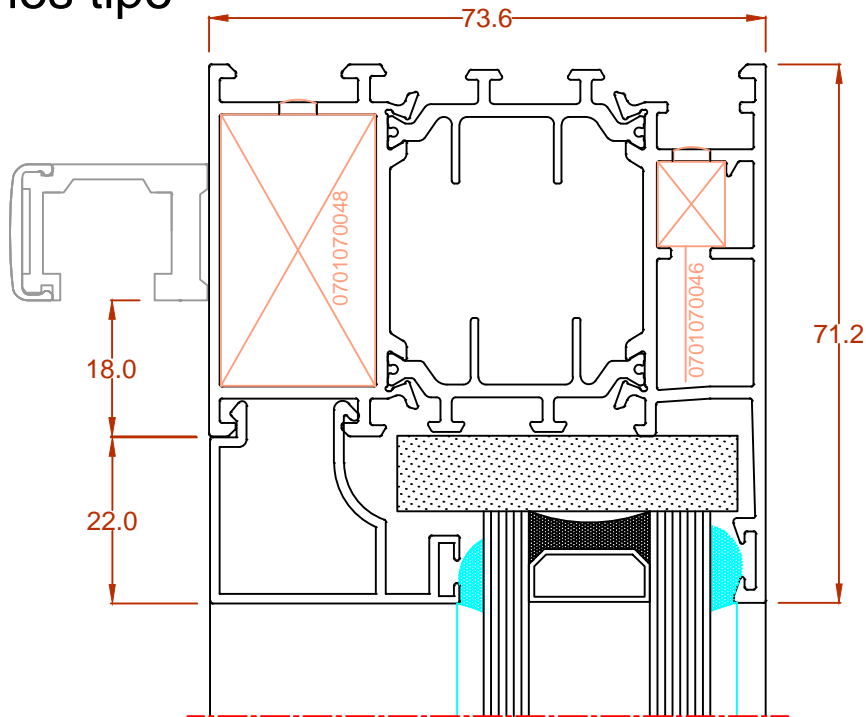

Secciones tipo

RT74 CE - G21

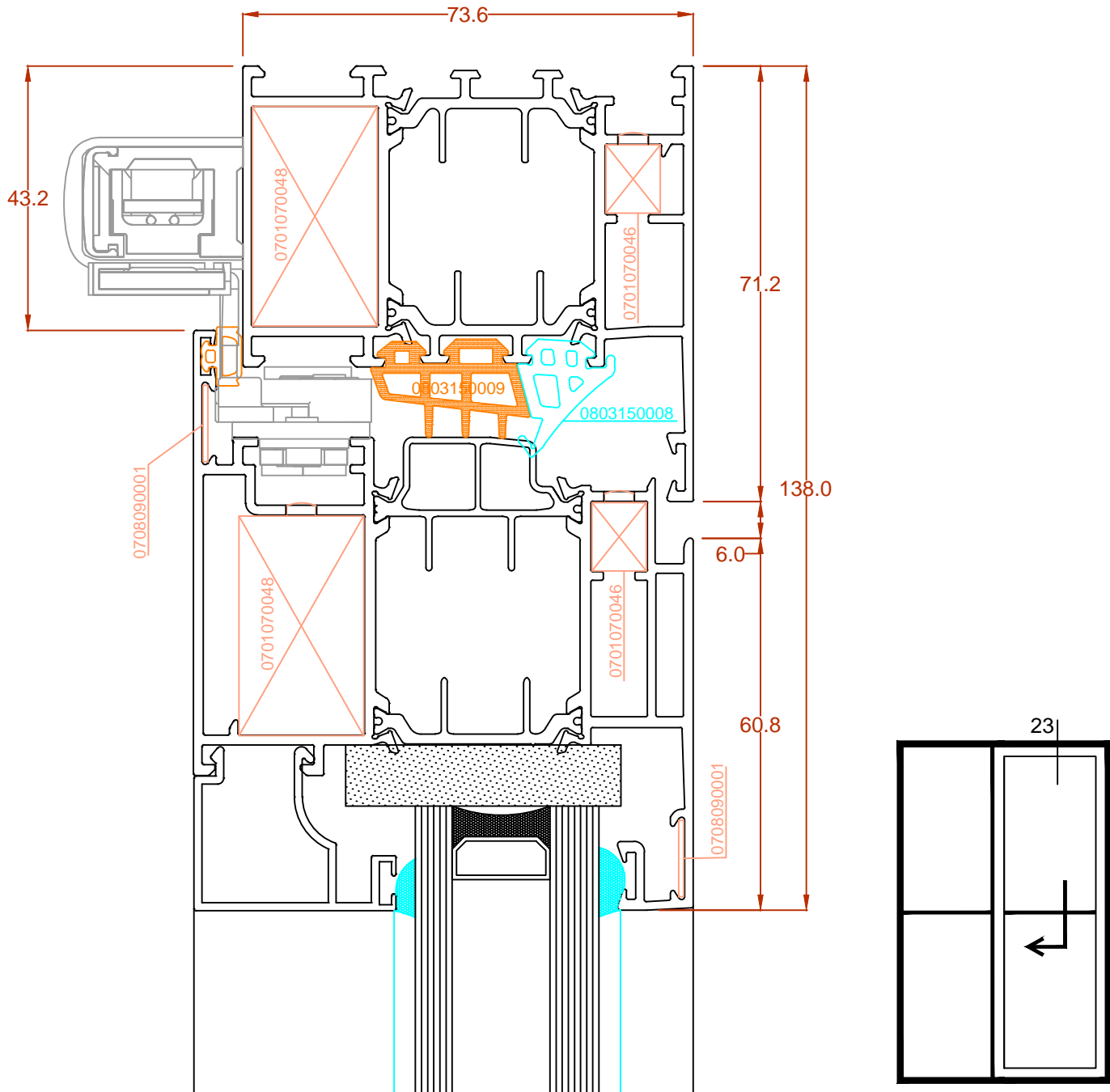

Secciones tipo

RT74 CE - G22

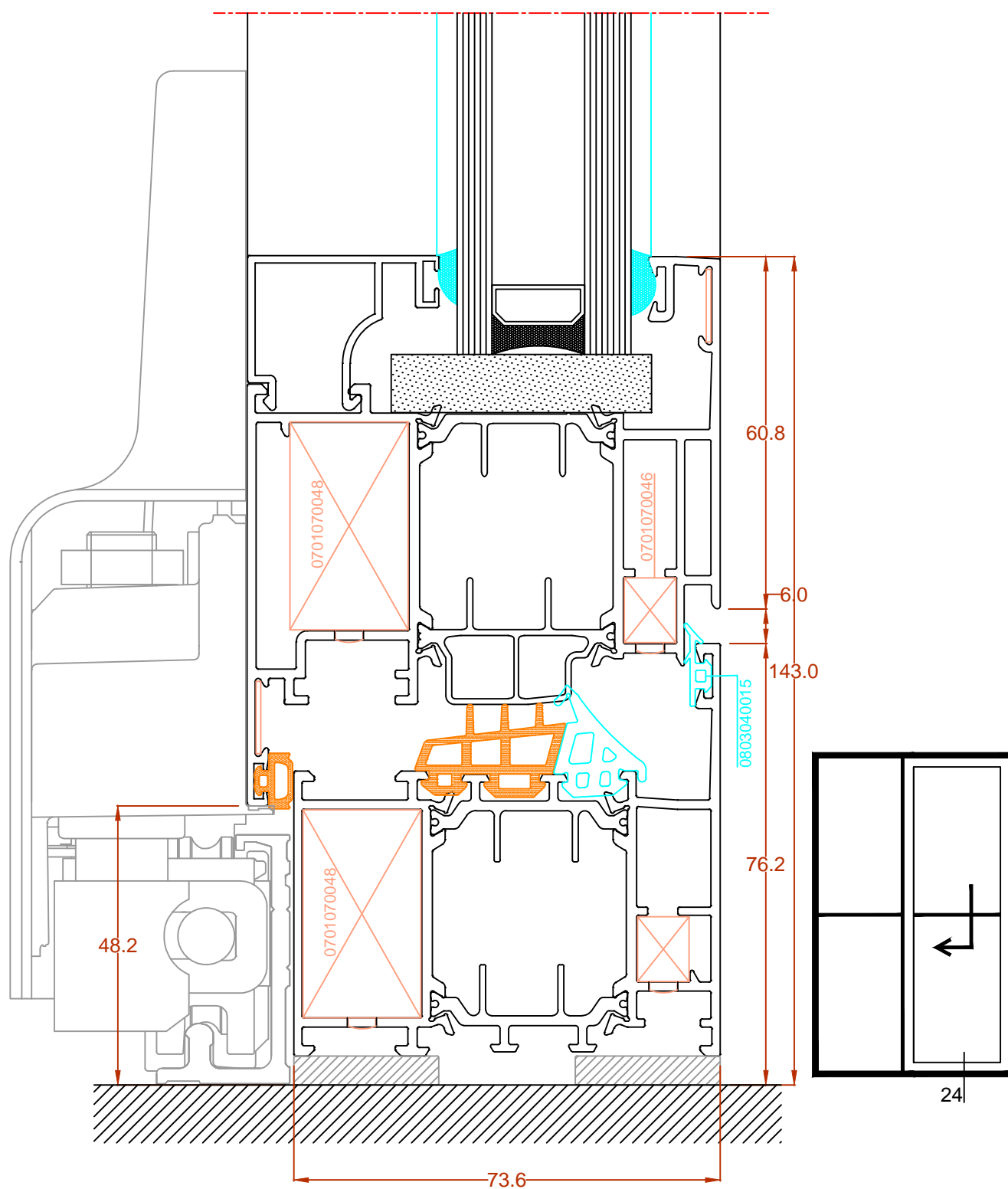

Secciones tipo

RT74 CE - G23

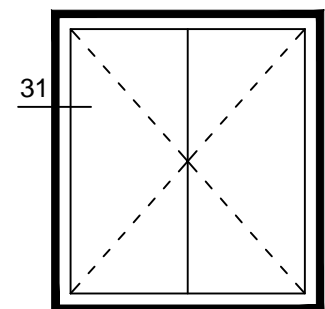
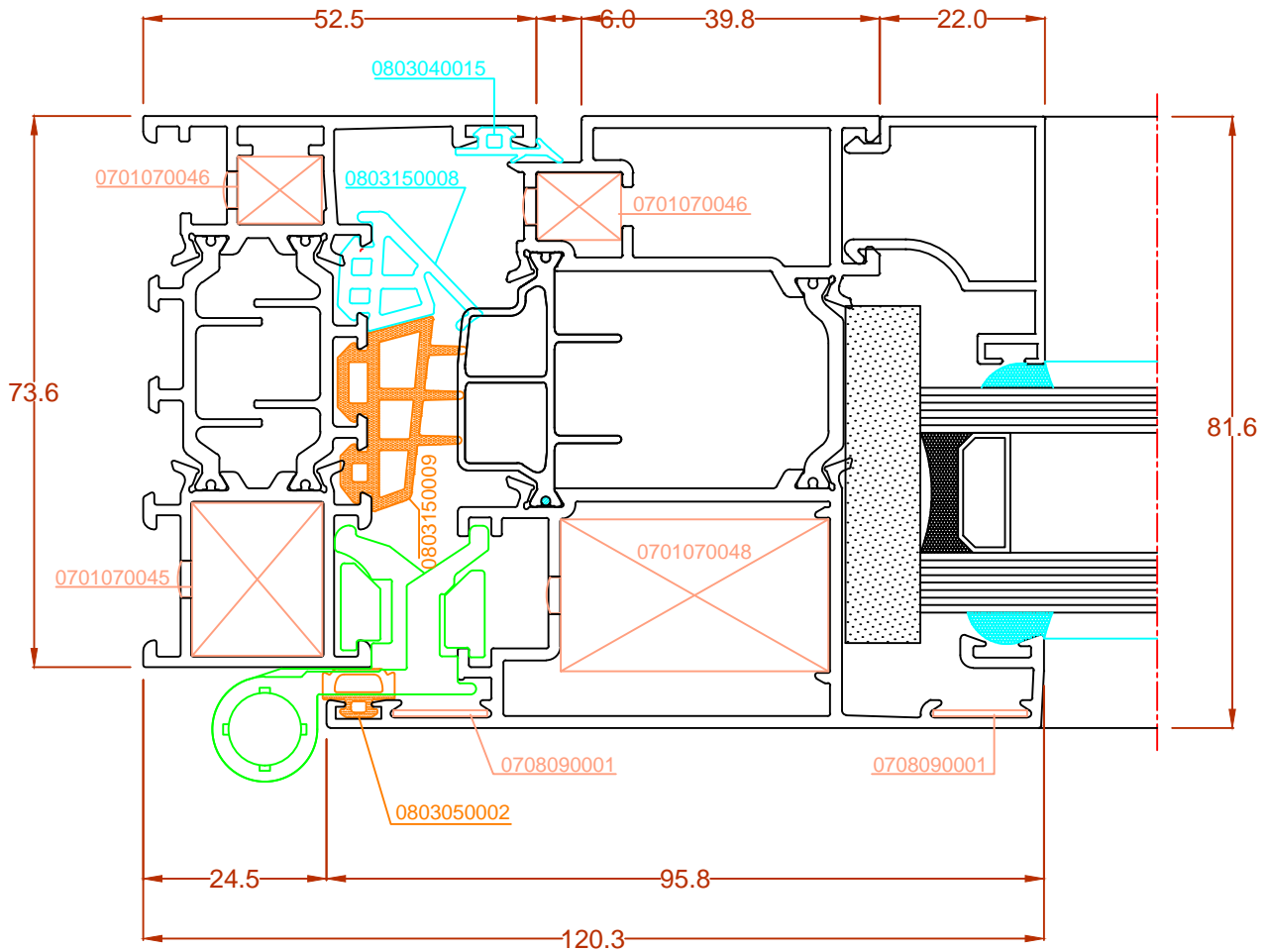

Secciones tipo

RT74 CE - G24

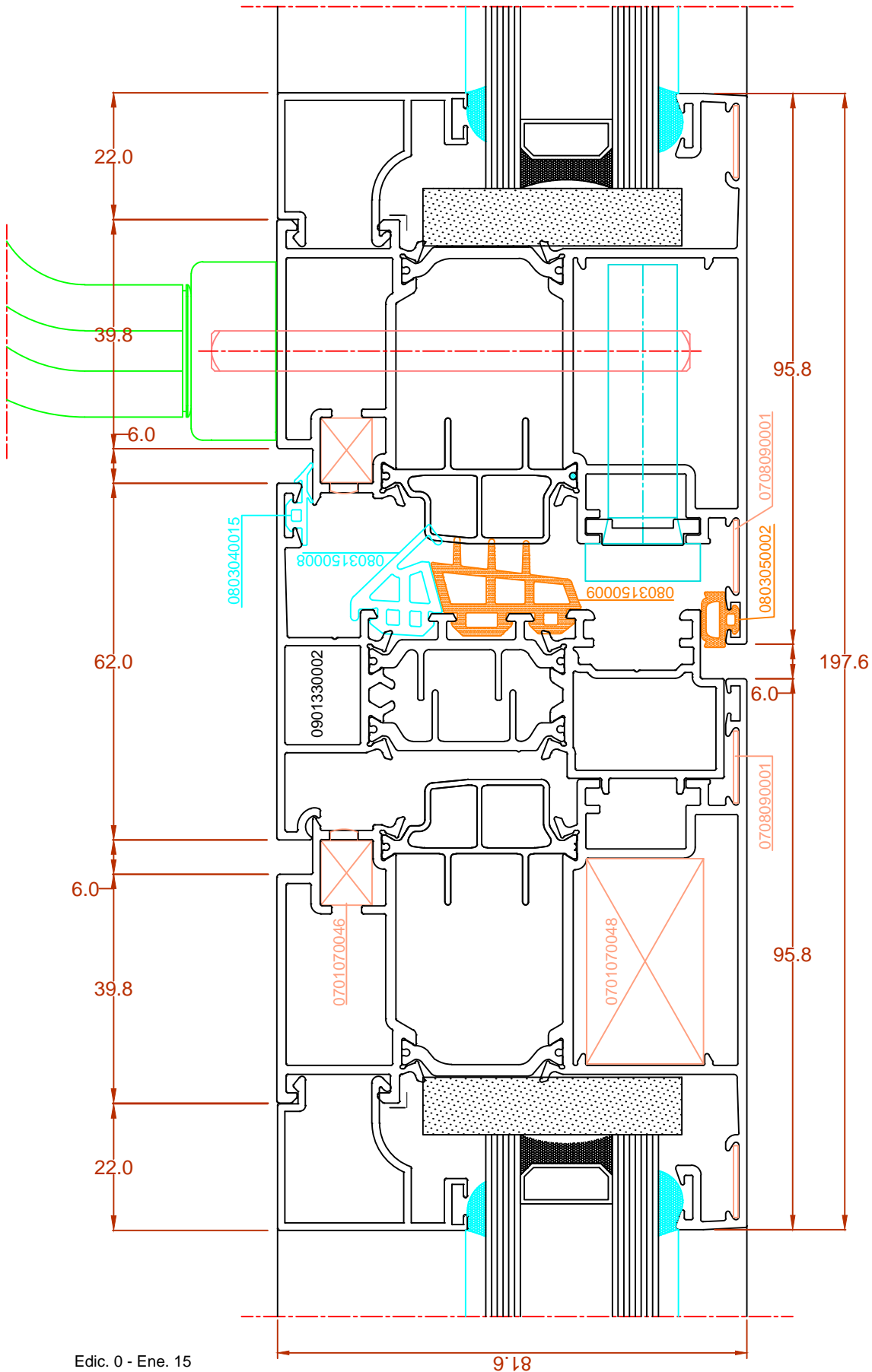

Secciones tipo

RT74 CE - G25

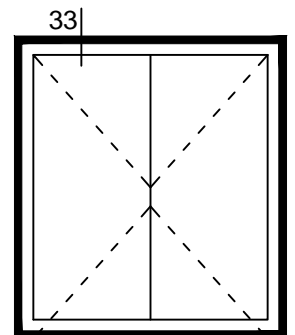
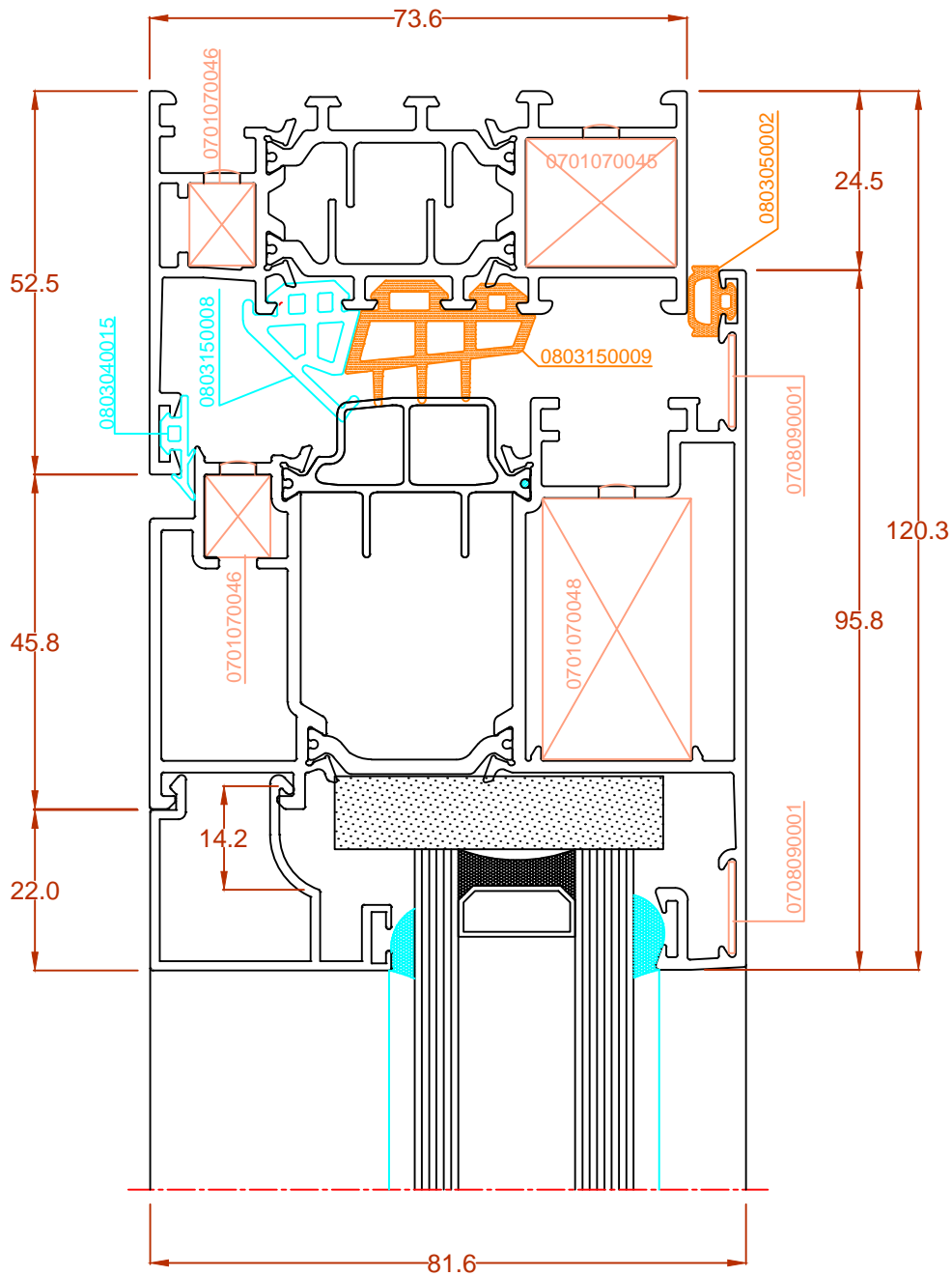

Secciones tipo

RT74 CE - G26

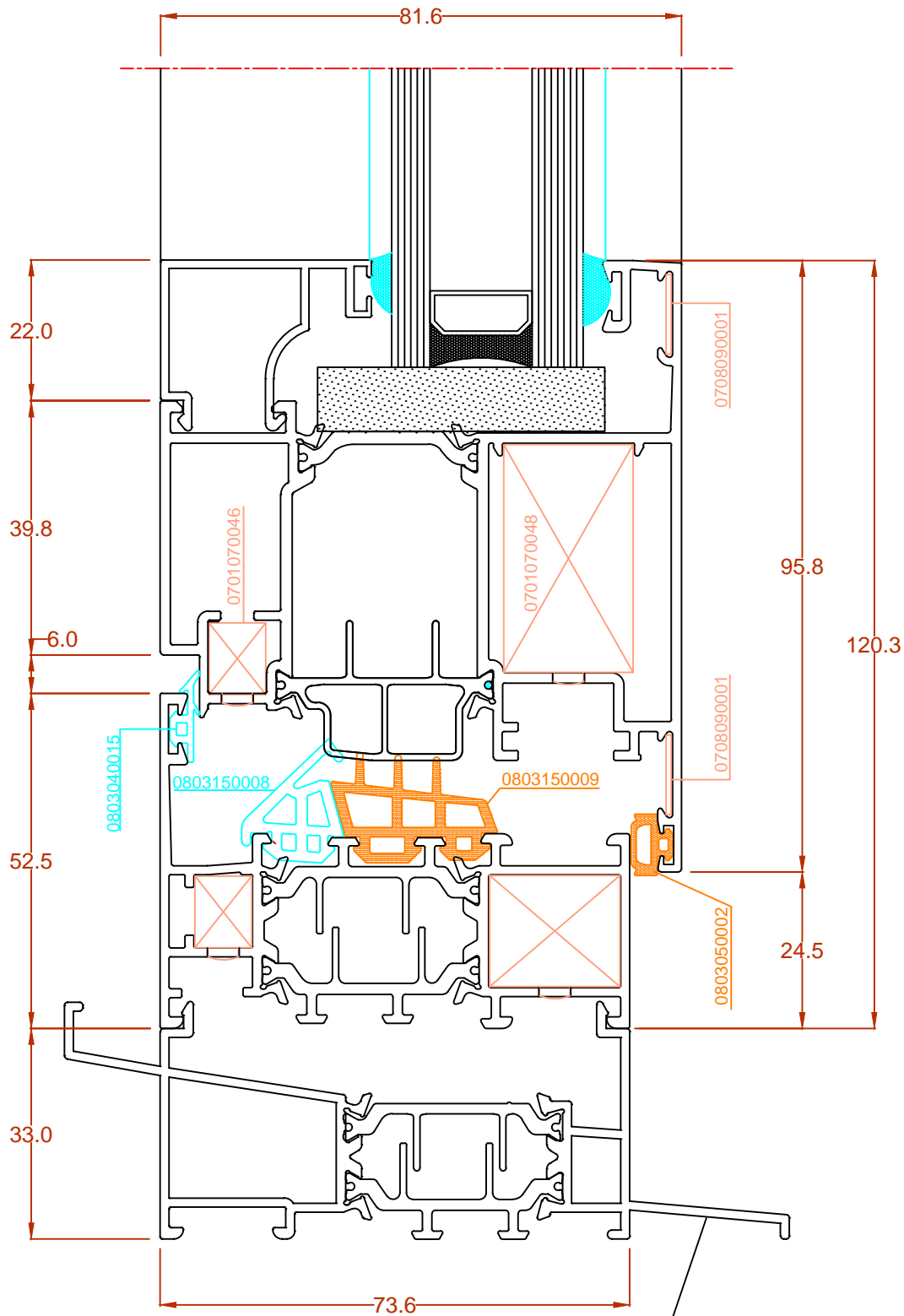

Ver alternativas en Secciones 6A, 6B, 6C

Secciones tipo

RT74 CE - G27

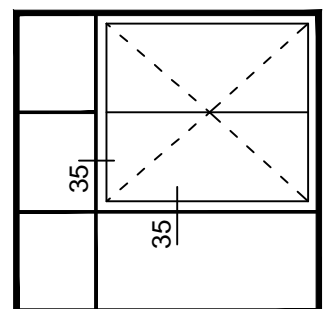
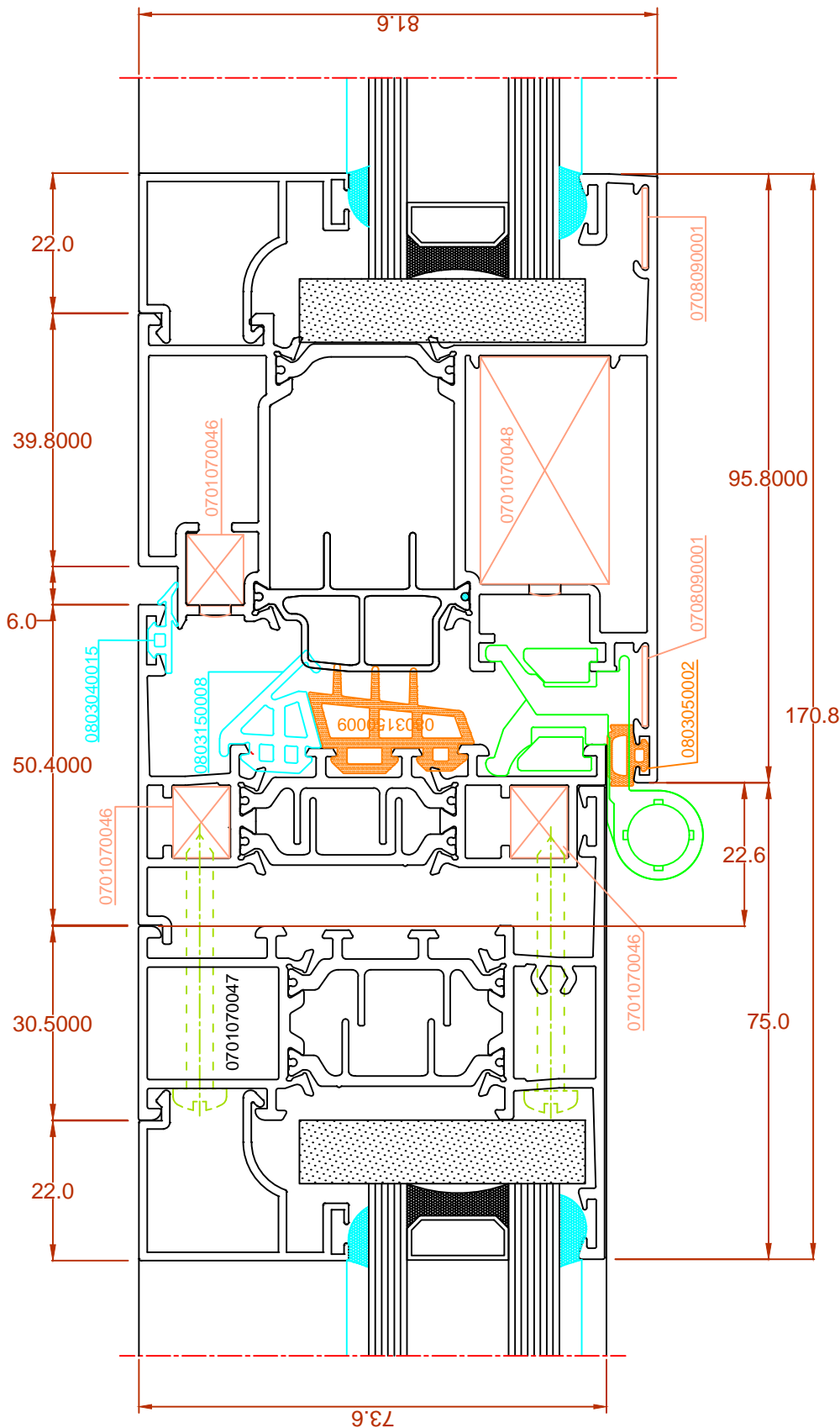

Secciones tipo

RT74 CE - G28

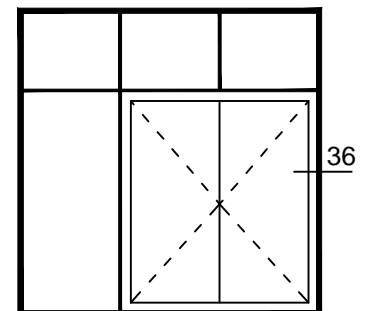
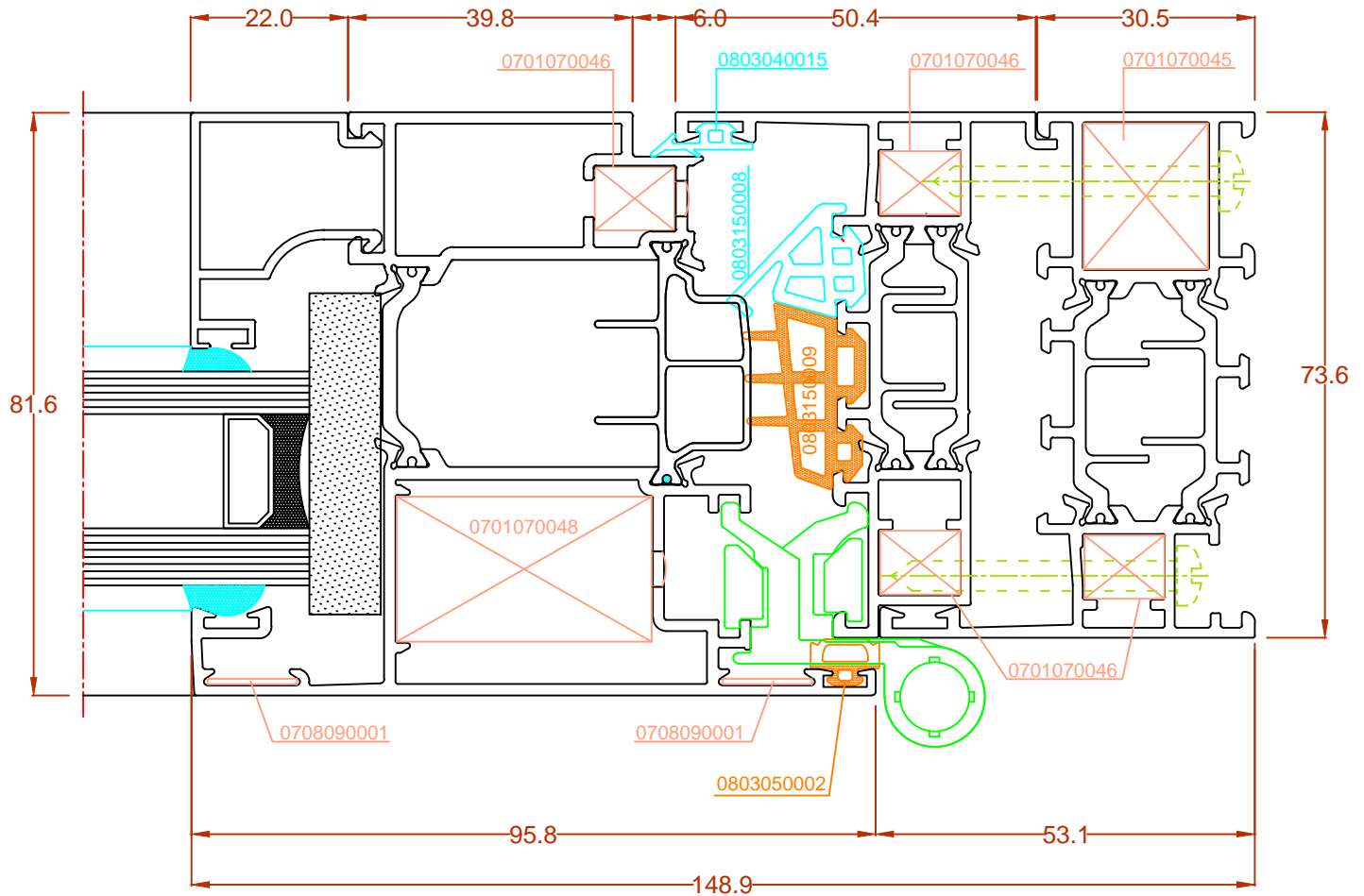

Secciones tipo

RT74 CE - G29

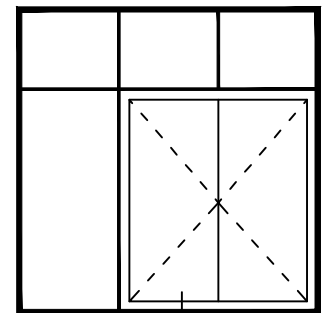
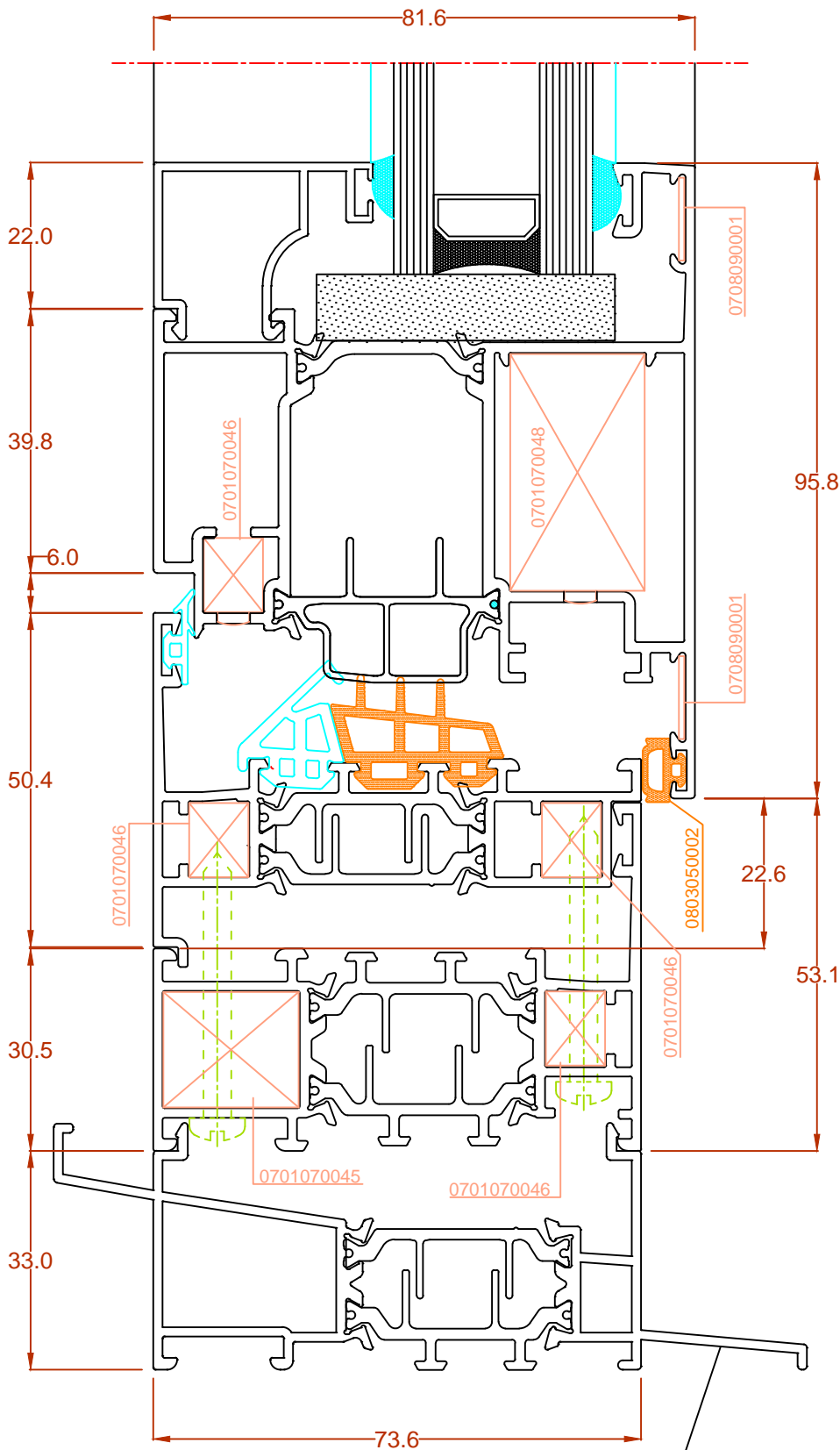

37

Ver alternativas en Secciones 6A, 6B, 6C

Secciones tipo

RT74 CE - G30

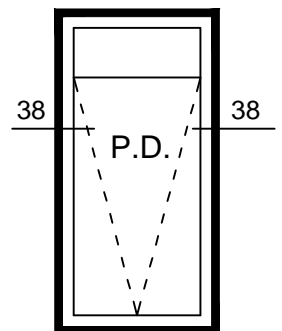
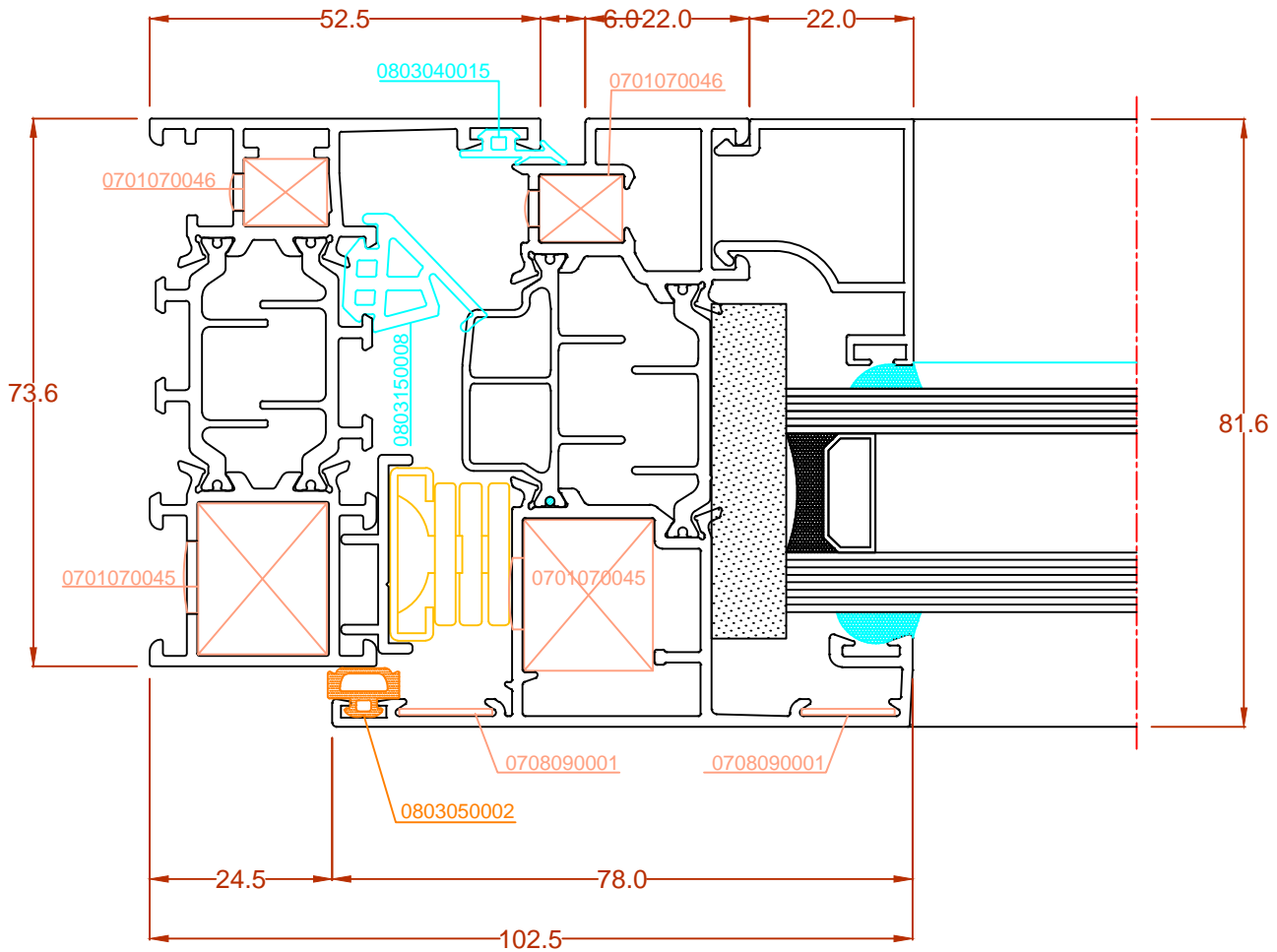

Secciones tipo

RT74 CE - G31

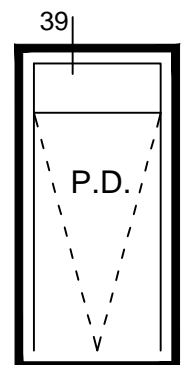
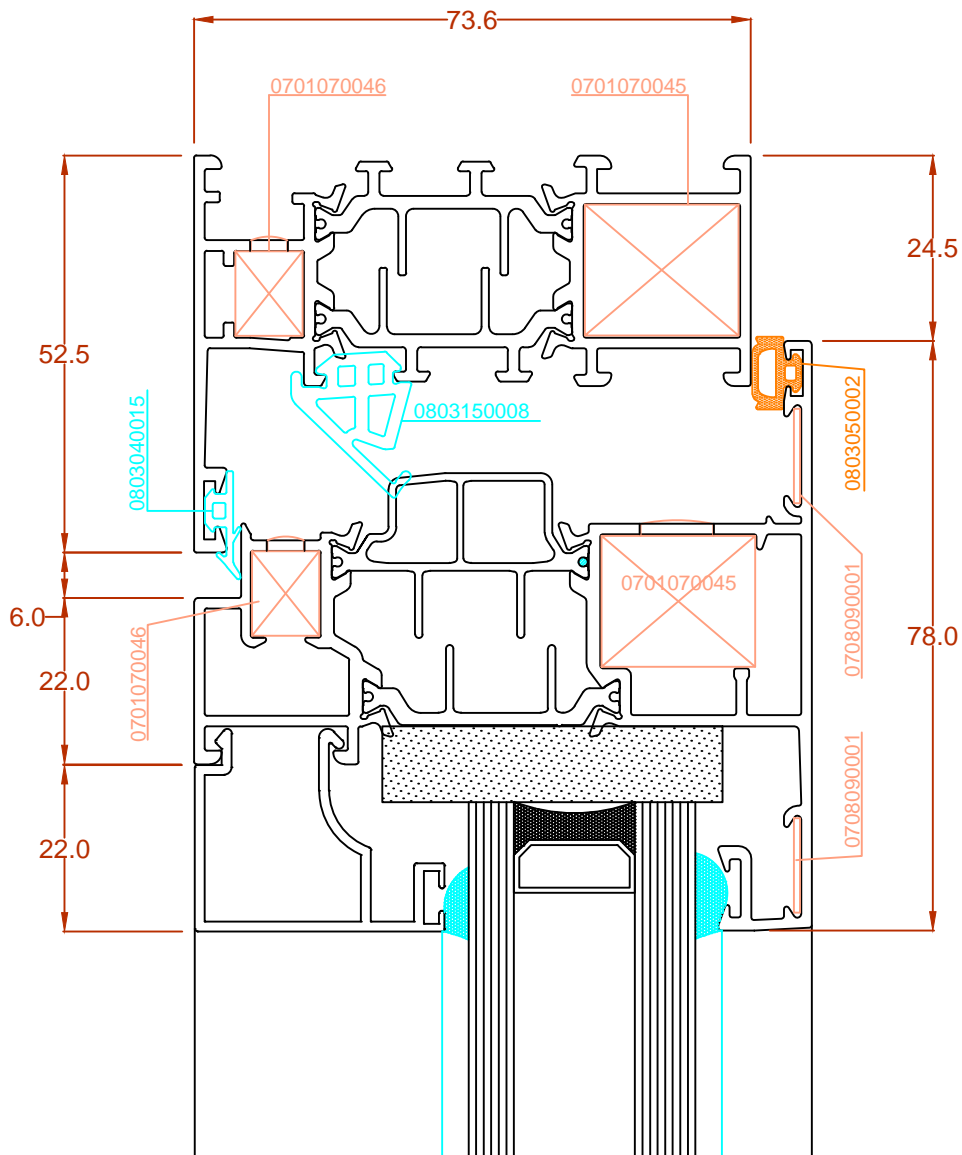

Secciones tipo

RT74 CE - G32

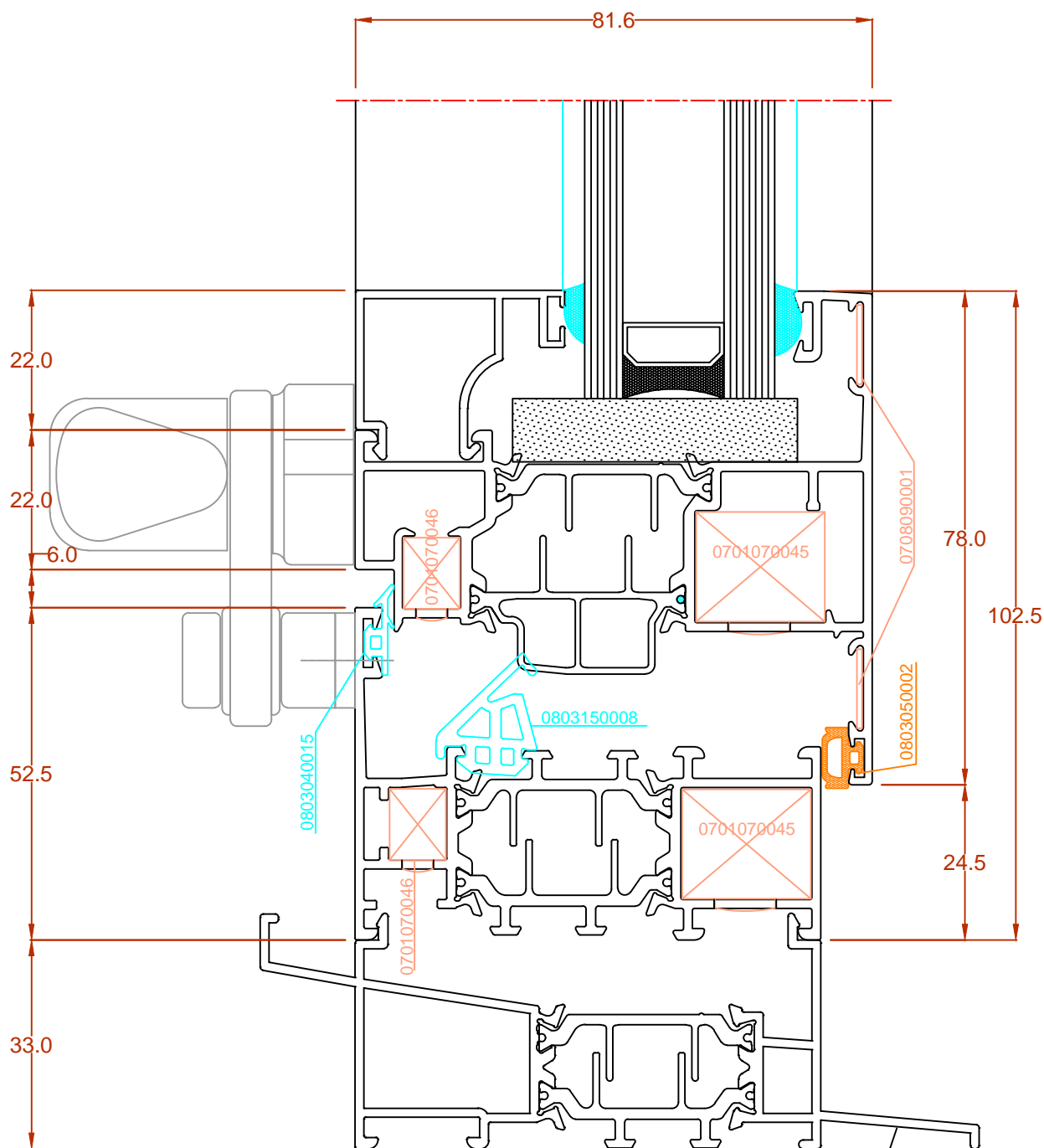

Ver alternativas en Secciones 6A, 6B, 6C

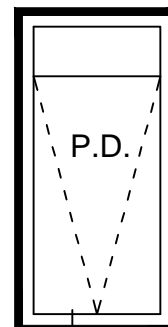

40

Secciones tipo

RT74 CE - G33

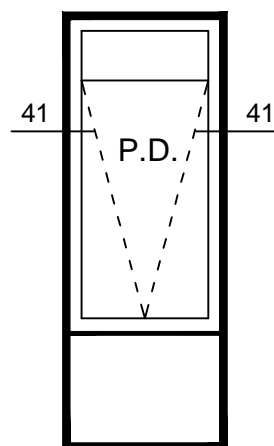
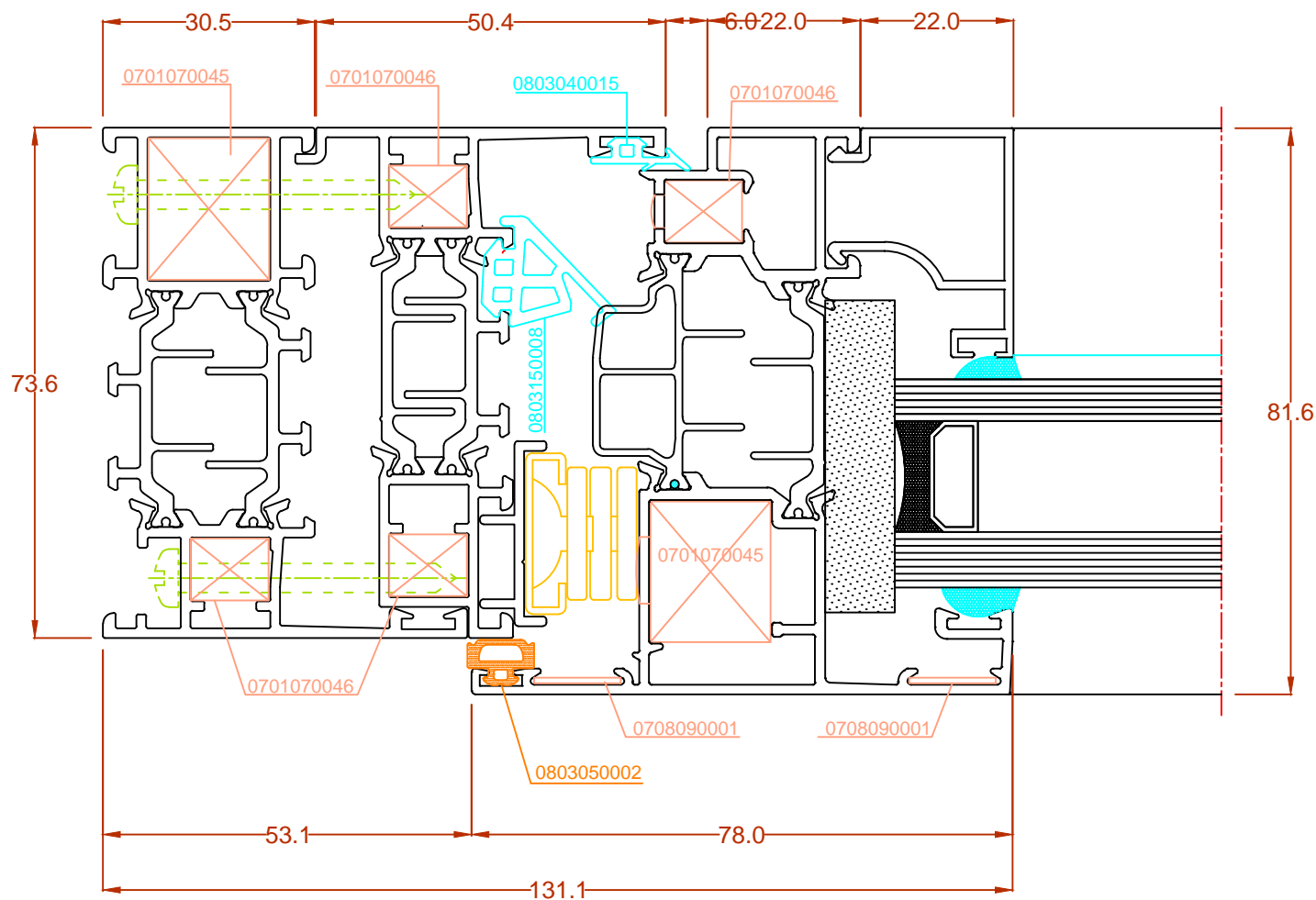

Secciones tipo

RT74 CE - G34

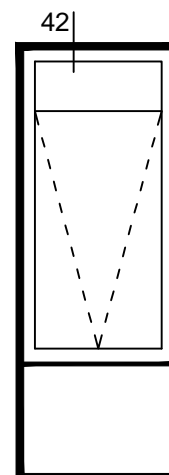
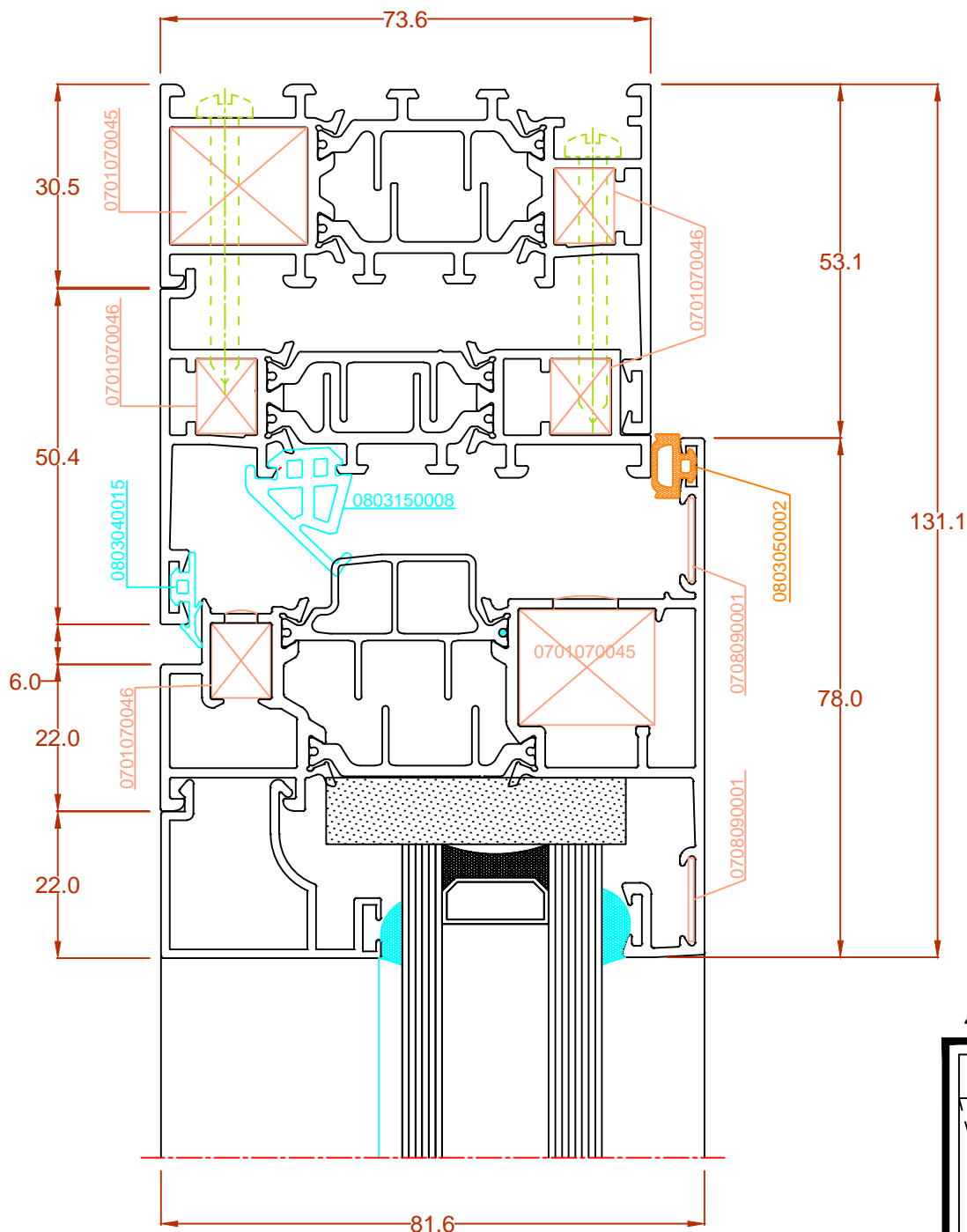

Secciones tipo

RT74 CE - G35

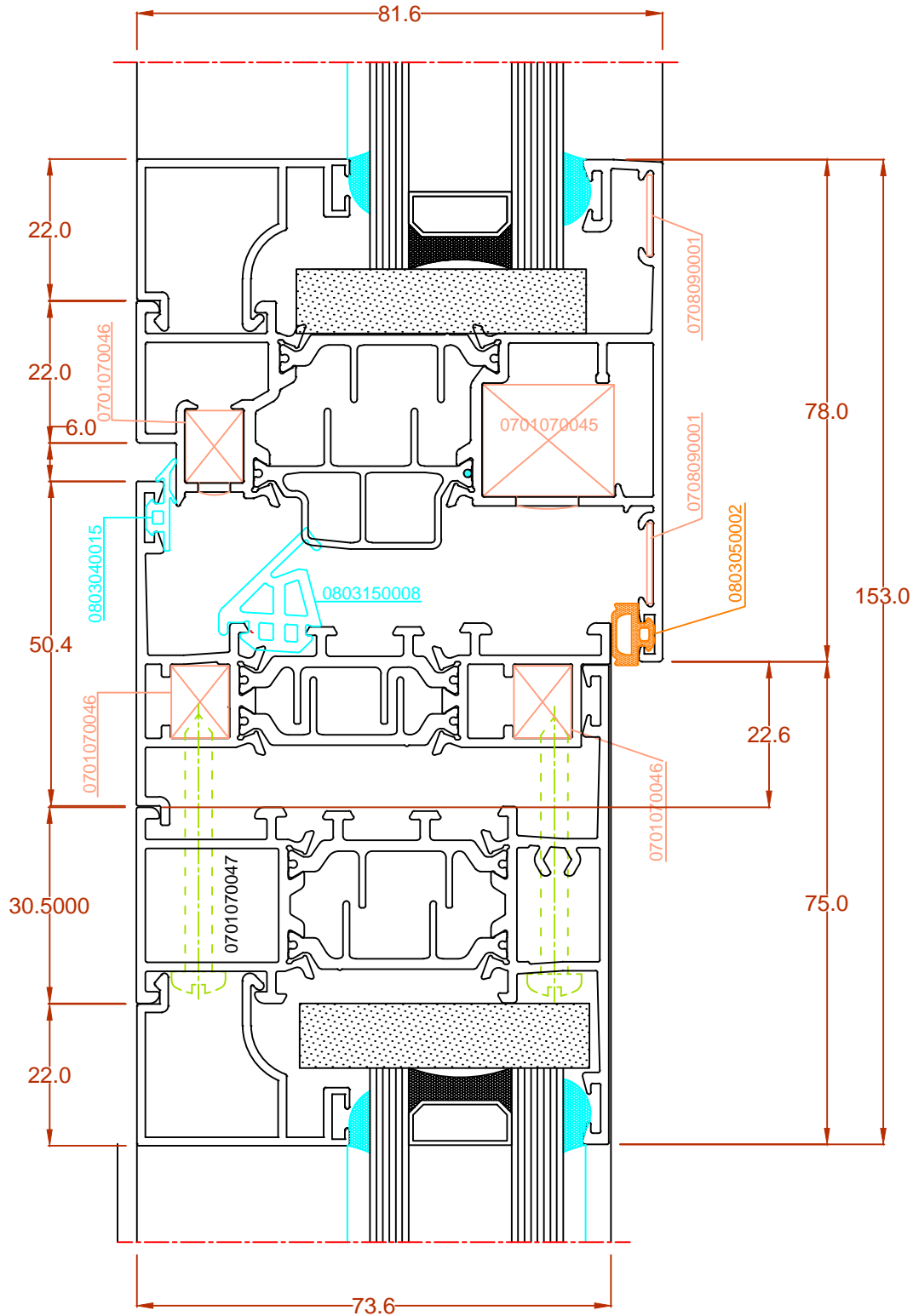

Secciones tipo

RT74 CE - G36

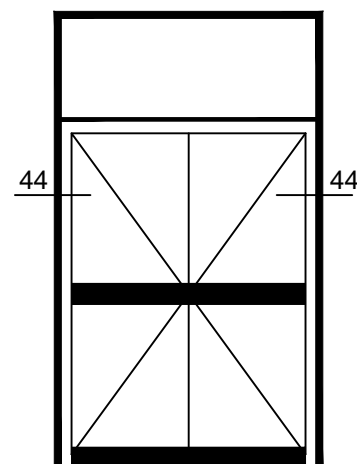
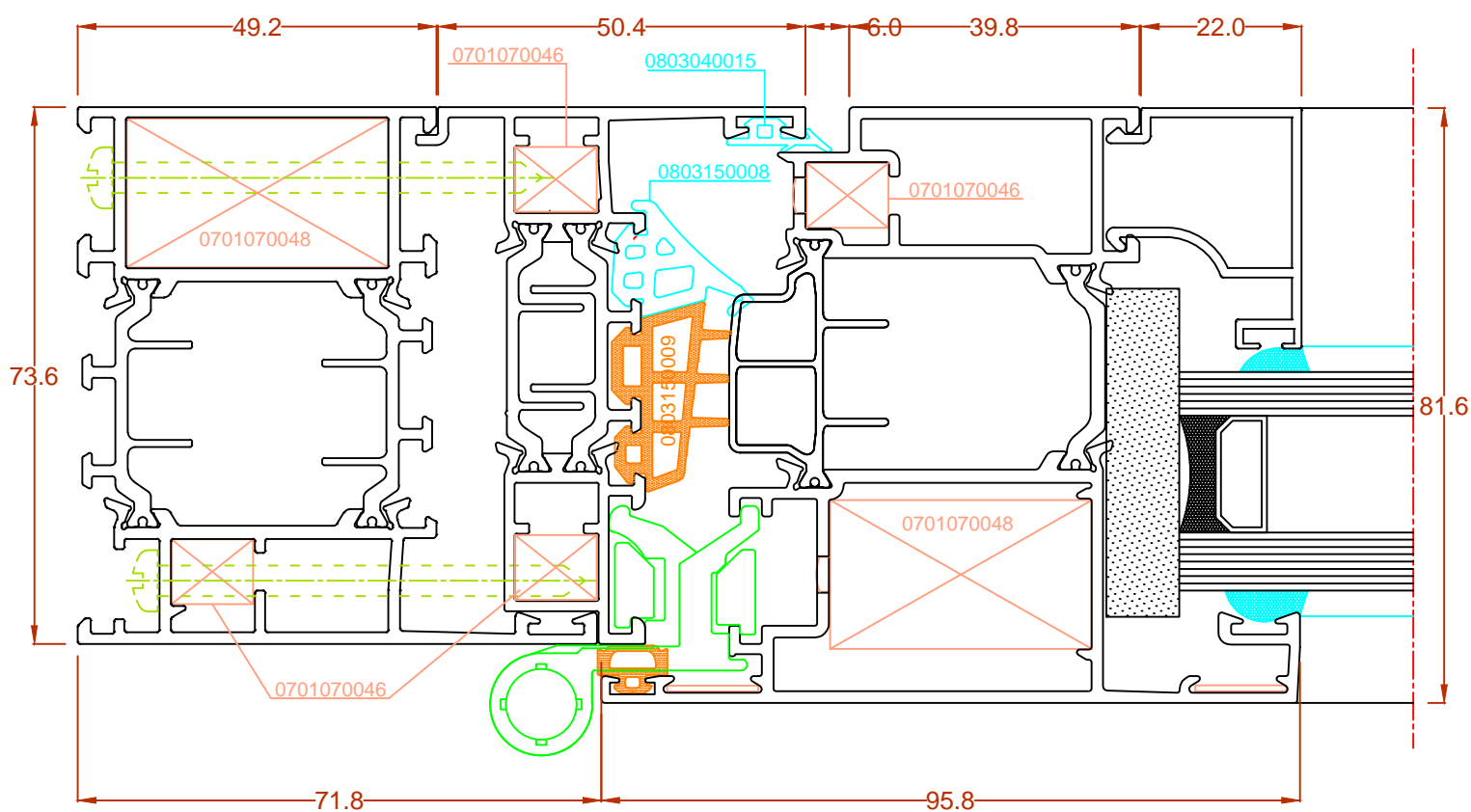

Secciones tipo

RT74 CE - G37

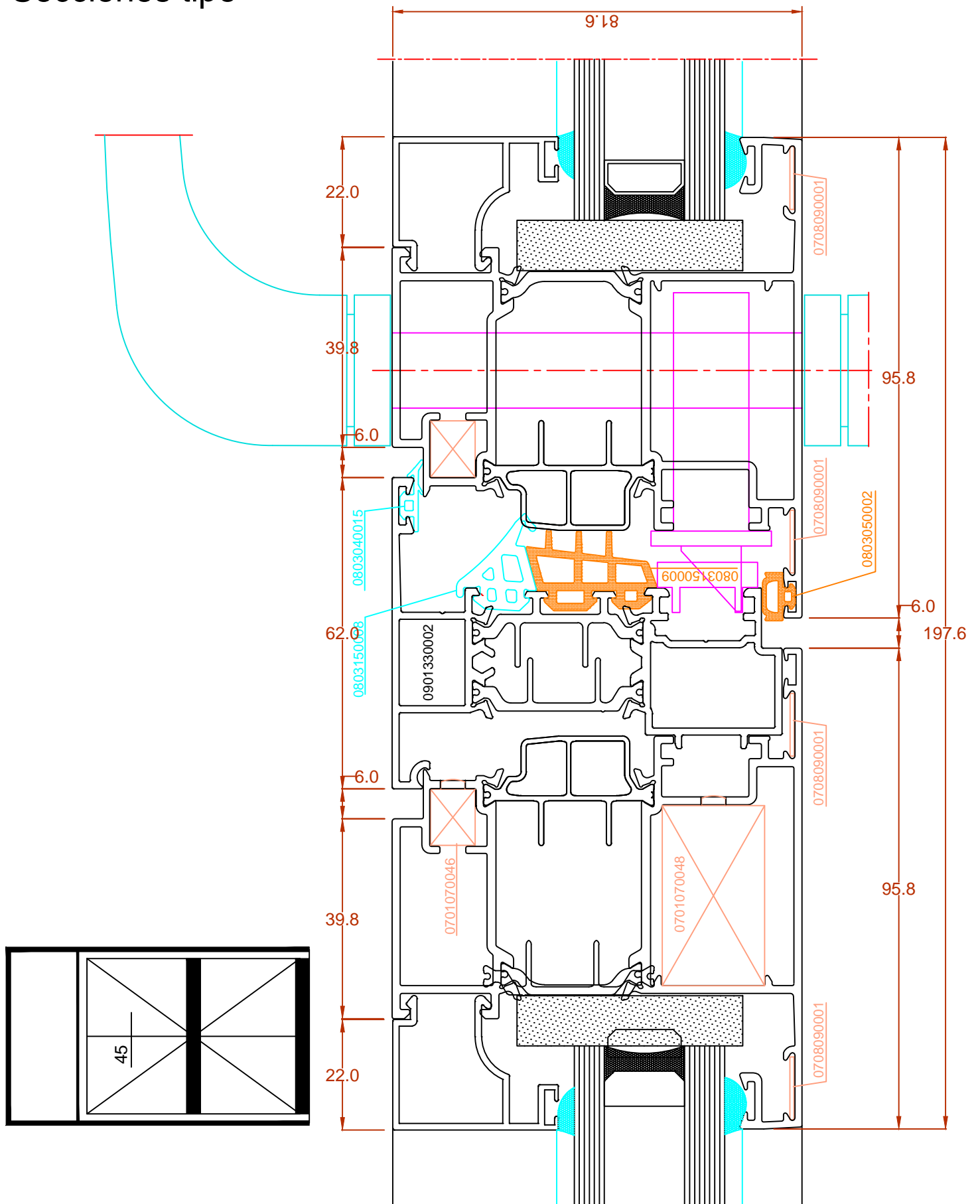

Secciones tipo

RT74 CE - G38

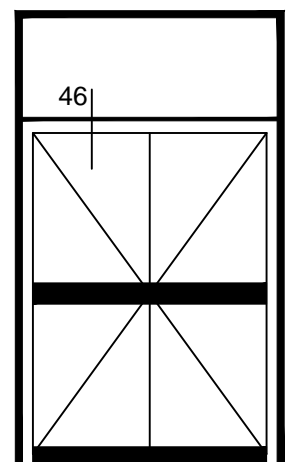
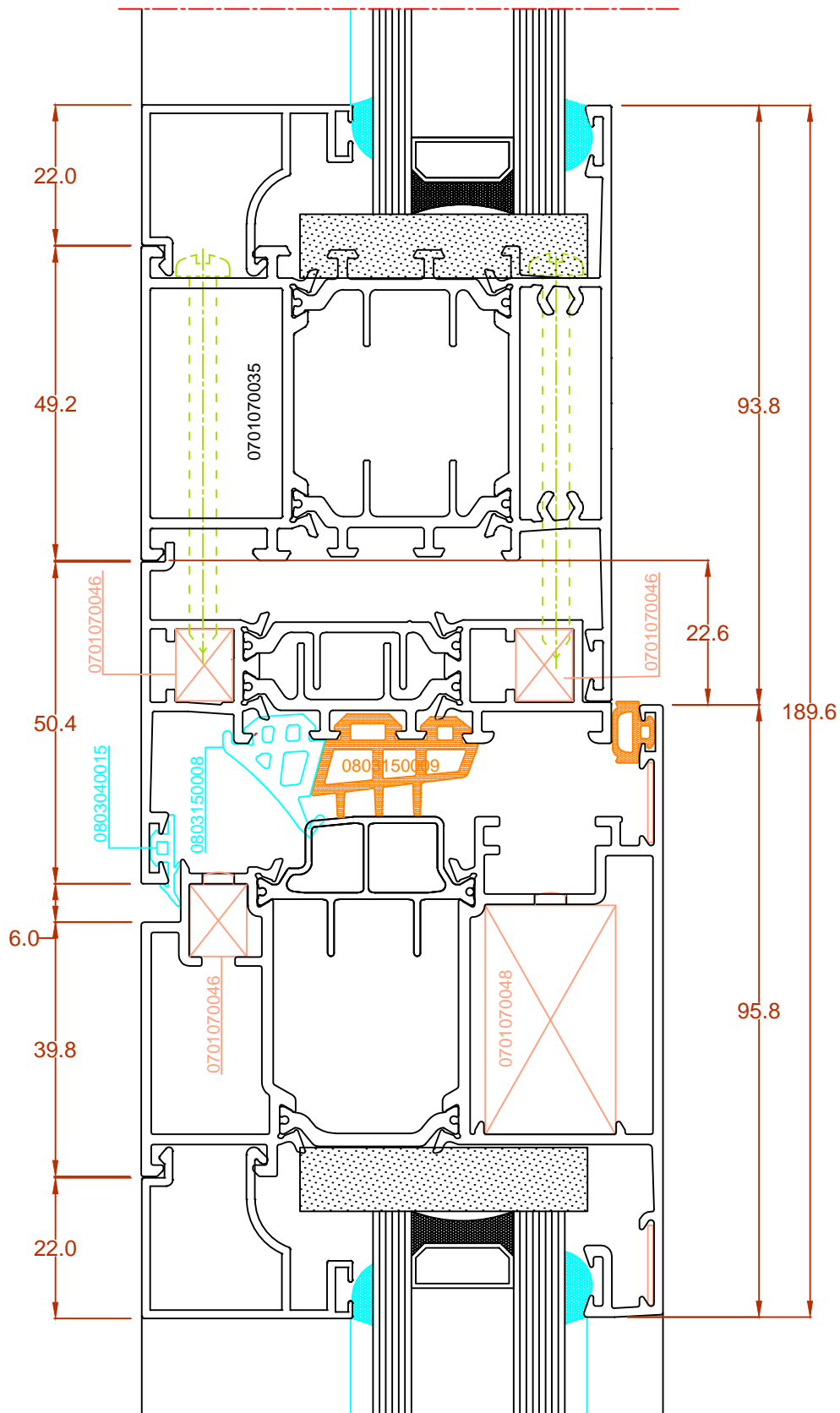

Secciones tipo

RT74 CE - G39

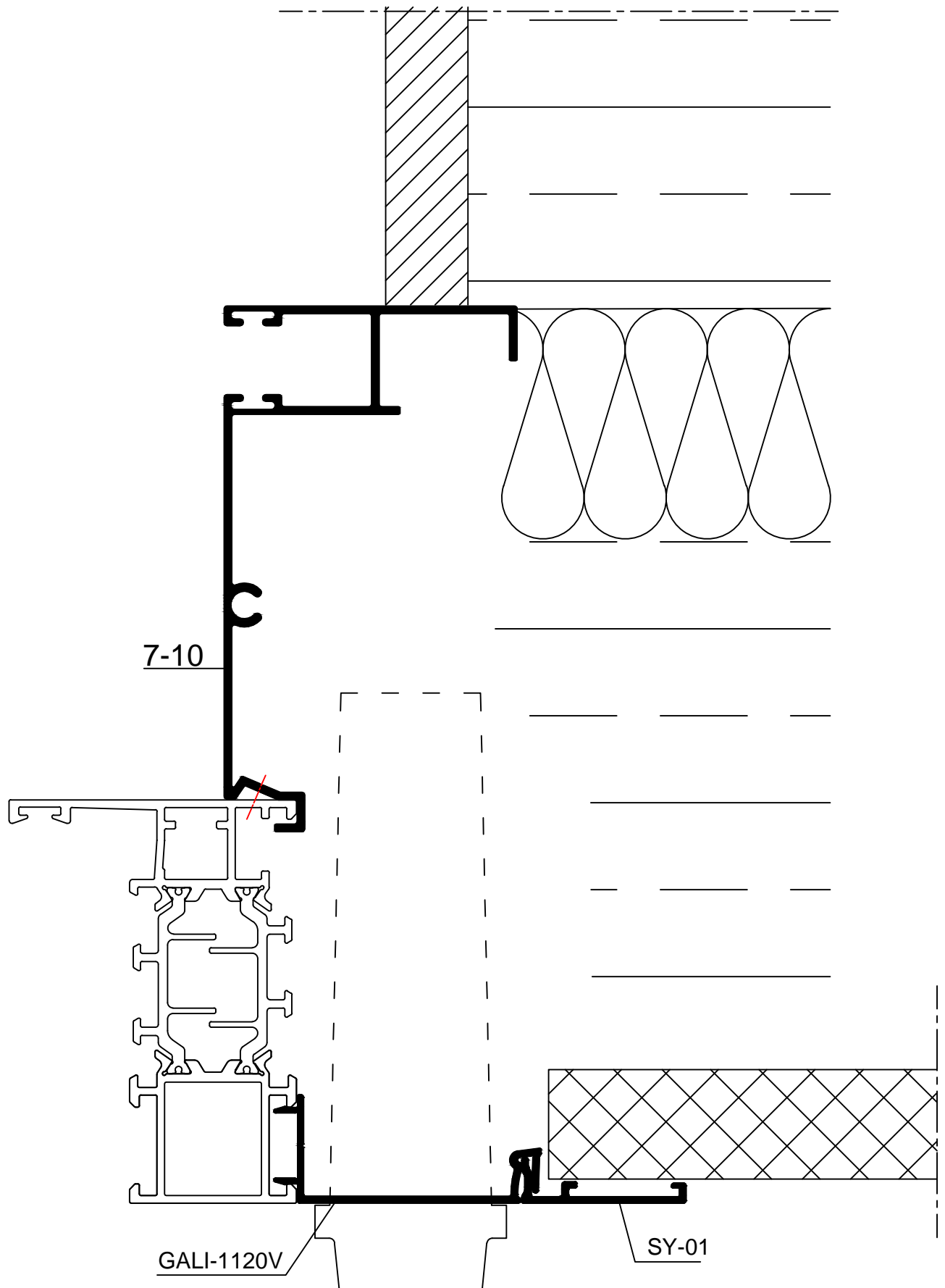

Secciones tipo

RT74 CE - G40

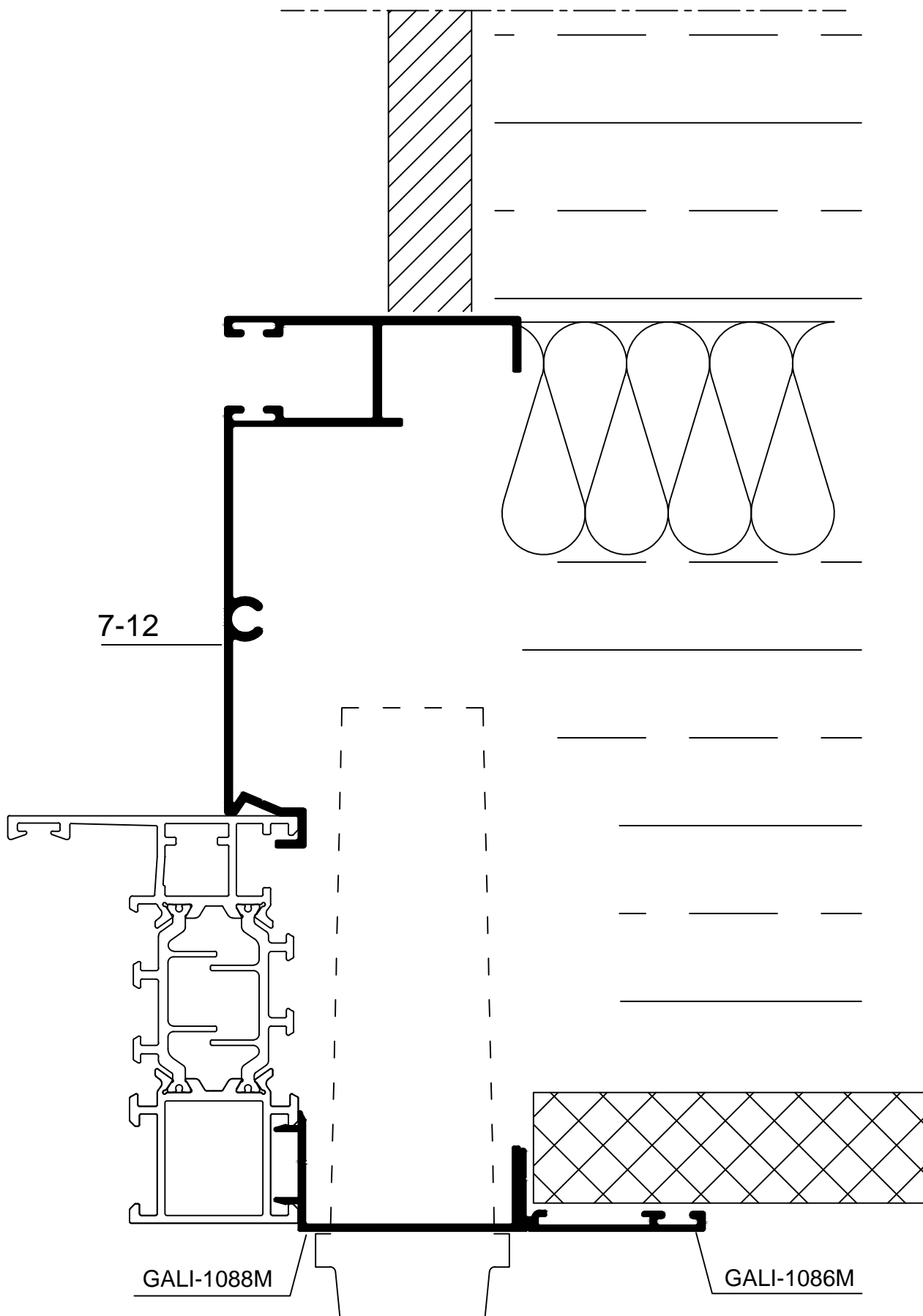

Secciones tipo

RT74 CE - G41

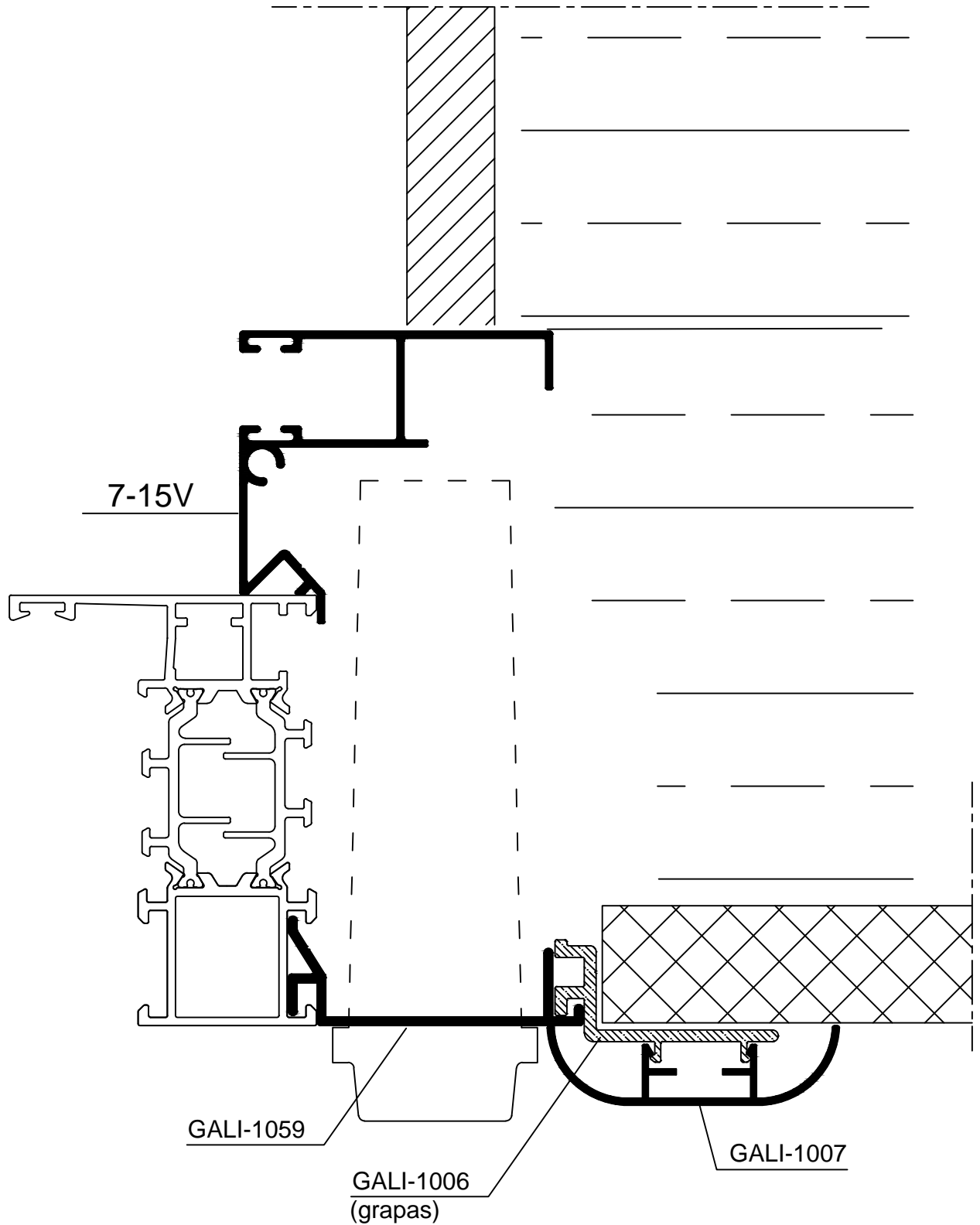

Secciones tipo

RT74 CE - G42

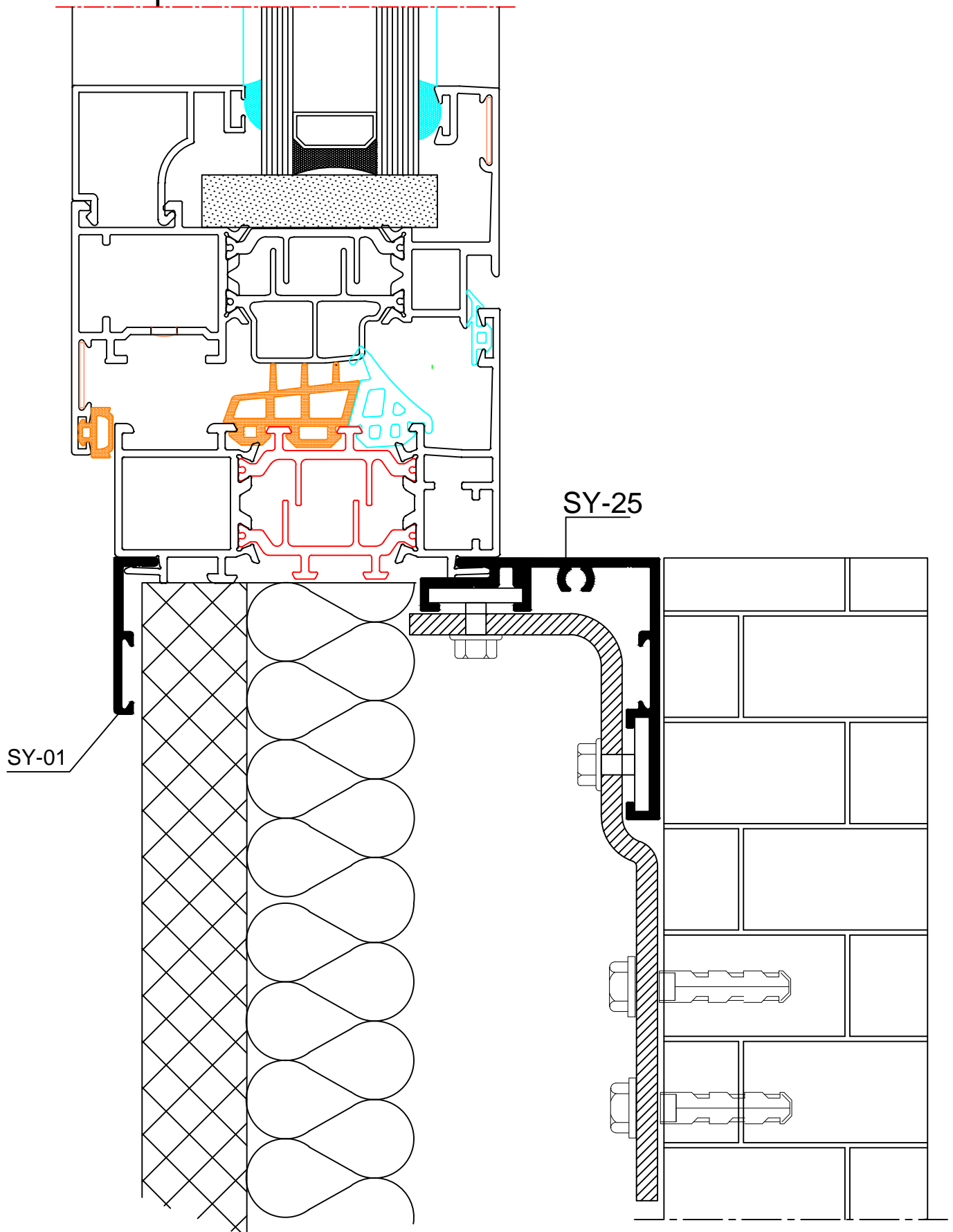

Secciones tipo

RT74 CE - G43

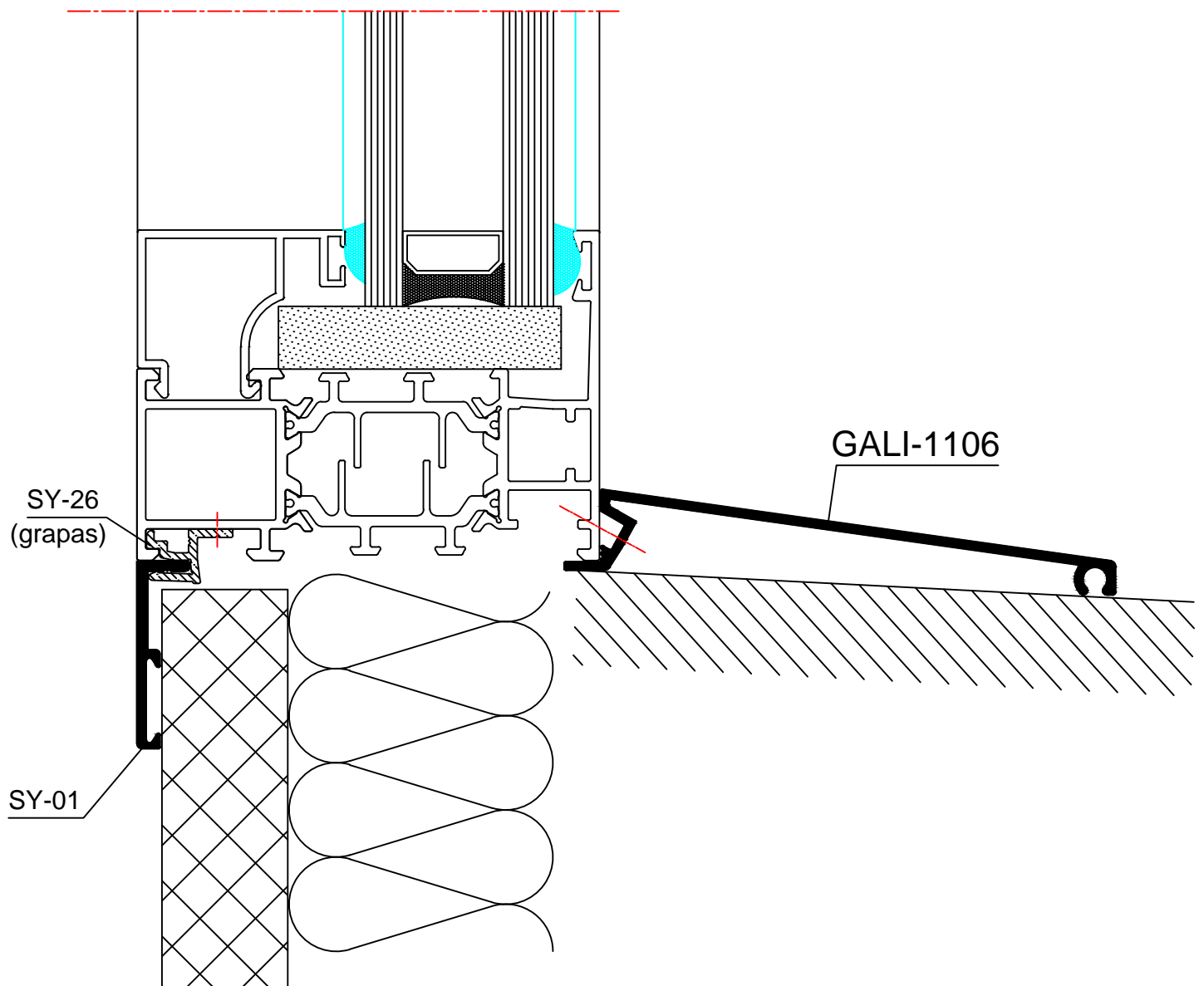

Secciones tipo

RT74 CE - G44

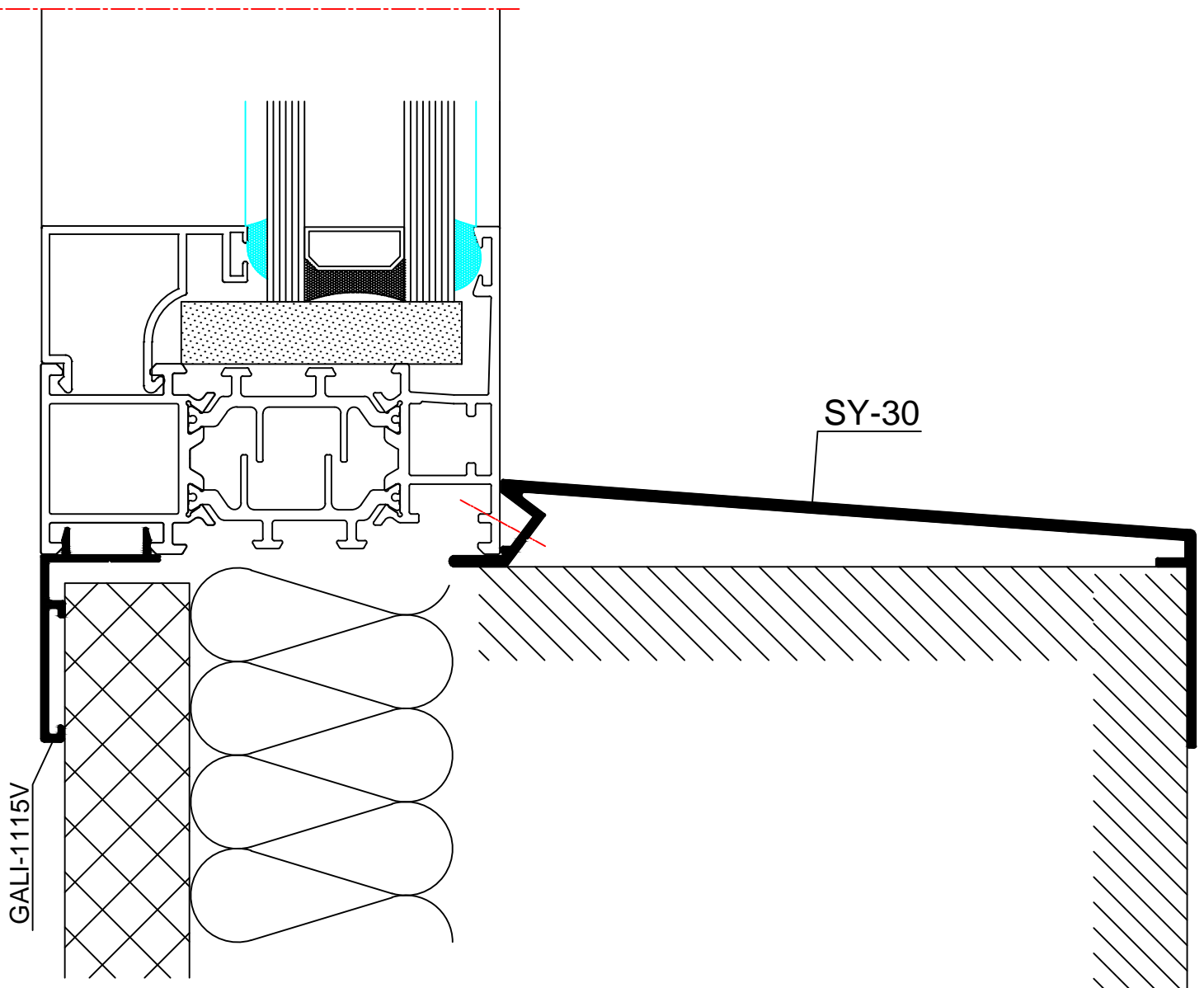

Hojas de corte

GUÍA

RT74 CE - F1

Ventanas abrir interior

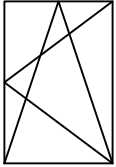

Hoja F-i1

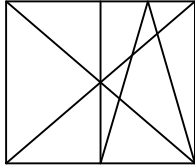

Hoja F-i2

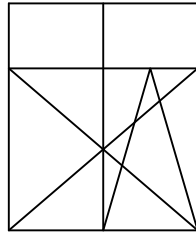

Hoja F-i3

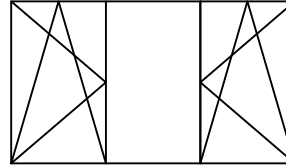

Hoja F-i4

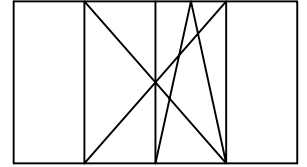

Hoja F-i5

Ventanas abrir exterior

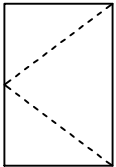

Hoja F-e1

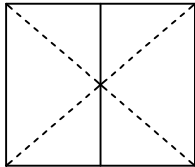

Hoja F-e2

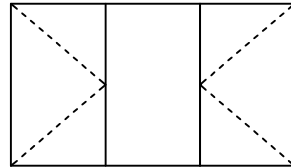

Hoja F-e3

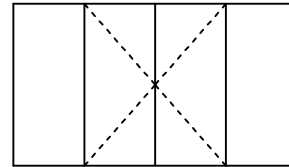

Hoja F-e4

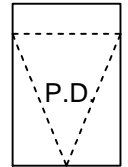

Hoja F-e5

Balconeras abrir int.

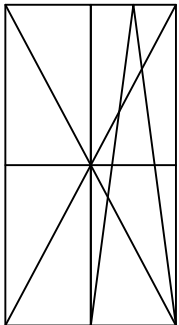

Hoja F-Bi1

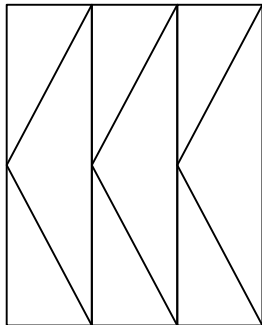

Hoja F-Bi2

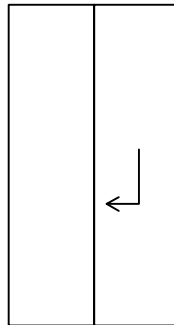

Hoja F-Bi3

Balconeras abrir ext.



Hoja F-Be1

Puertas entr. abrir int.

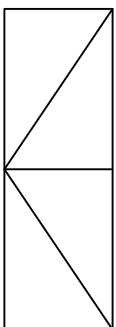

Hoja F-Pi1

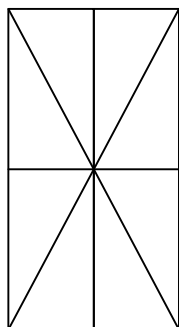

Hoja F-Pi2

Puertas entr. abrir ext.



Hoja F-Pe1

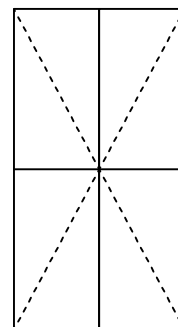











Hoja F-Pe2

Hojas de corte Ventana 1 hoja apertura interior

RT74 CE - Fi1

PERFILES



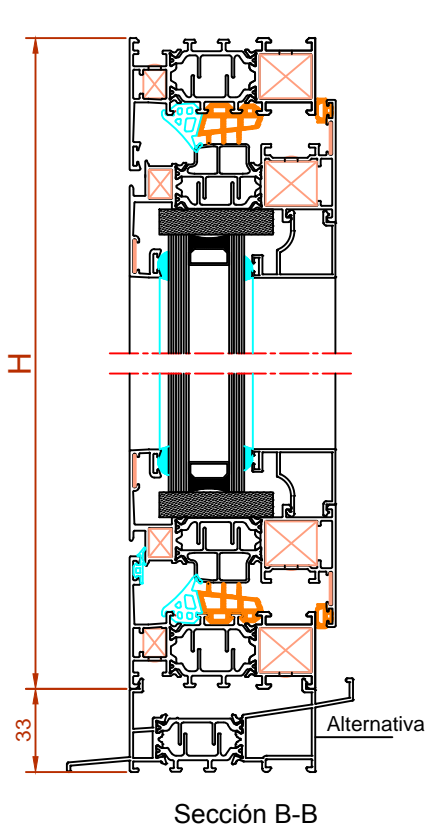

Croquis	Referencia	Corte	Medida	Cant.
	74-01		L	2
			H *	2
	74-02		L - 49	2
			H - 49*	2
	Según vidrio		L-146	2
	S90-50E		H-190*	2
	BX-51		Aprox H/2 **	2
	Alternativa *		L	1
	74-05			

* Medida sin condensador; caso de llevarlo reduce la altura 33 mm

** Para ventana practicable; para oscilo. ver pag. Fi6



Juntas

Ref.	Croquis	Cant.
0803150008		2xL+2xH
0803150009		2xL+2xH
0803040015		2xL+2xH
0803050002		2xL+2xH
		2xL+2xH (Opcional bajo vidrio)

VIDRIOS

Ancho	Alto	Cant.
L-157	H-157 *	1

ACCESORIOS

Ref.	Descripción	Cant.	
		Pract.	Oscilo.
0302010001	Cremona pract. int.		—
0417010001	Kit practicable	1	—
060201000-1/2	Bisagra practica. Der. IZQ.	2	—
0407010004	Cerradero sup/inf	2	—
0302010002	Cremona oscilobat.	—	1
0202010001	Cjto. oscilobatiente	—	1
0101010002	Compas oscilo. (s/med.)	—	1
1103170002	Tapa salida agua	2*	(4)
0701070045	Escuadras 17x20	8	
0701070046	Escuadras 11x9	8	
0708090001	Escuadras alineami.	8	

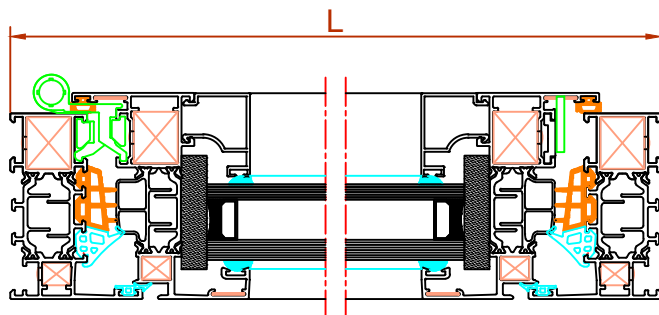







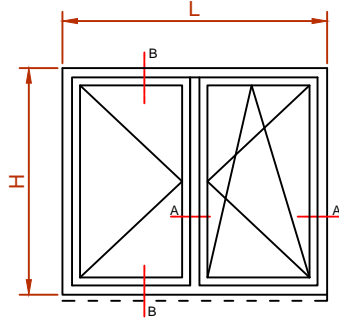
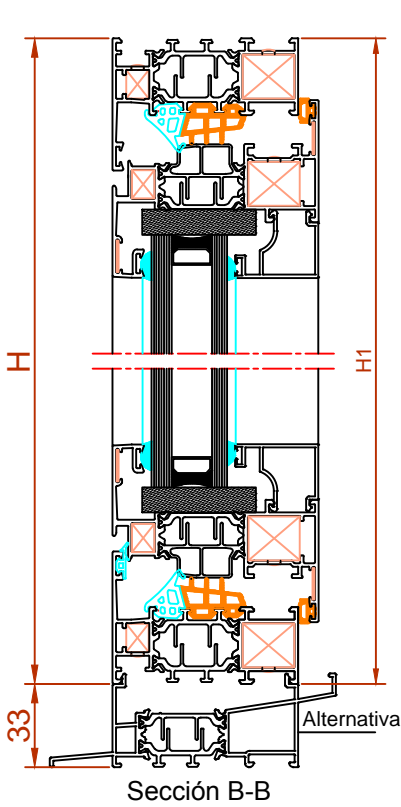





Sección A-A

Hojas de corte Ventana 2 hojas apertura interior

RT74 CE - F-i2







PERFILES

Croquis	Referencia	Corte	Medida	Cant.
	74-01		L	2
			H *	2
	74-02		L/2 - 27,5	4
			H - 49 *	4
	74-03		H - 122 *	1
	Según vidrio		L/2-124,5	4
	S90-50E		H-190 *	4
	BX-51		Aprox H/2 **	2
	Alternativa *		L	1
	74-05			

* Medida sin condensador; caso de llevarlo reduce la altura 33 mm

** Para ventana practicable; para oscilo. ver pag. Fi6

Juntas

Ref.	Croquis	Cant.
0803150008		2xL+3xH
0803150009		2xL+3xH
0803040015		2xL+3xH
0803050002		2xL+3xH
		2xL+4xH (Opcional bajo vidrio)

VIDRIOS

Ancho	Alto	Cant.
L/2-136	H-157 *	2

ACCESORIOS

Ref.	Descripción	Cant.	
		Pract.	Oscilo.
0302010001	Cremona pract. int.	1	—
0417010001	Kit practicable	1	—
0501010002	Juego pasador prac.	1	—
0602010001	Bisagra practicable der.	2	—
0602010002	Bisagra practicable izq.	2	—
0302010002	Cremona oscilobat.	—	1
0202010001	Cjto. oscilobatiente	—	1
0101010002	Compas oscilo. (s/med.)	—	1
0202010003	Cjto. bisagras simet.	—	1
0501010001	Juego pasador osc.	—	1
0901330002	Juego tapa inversora	1	
1103170002	Tapa salida agua	2* (4)	
0701070045	Escuadras 17x20	12	
0701070046	Escuadras 11x9	12	
0708090001	Escuadras alineami.	16	

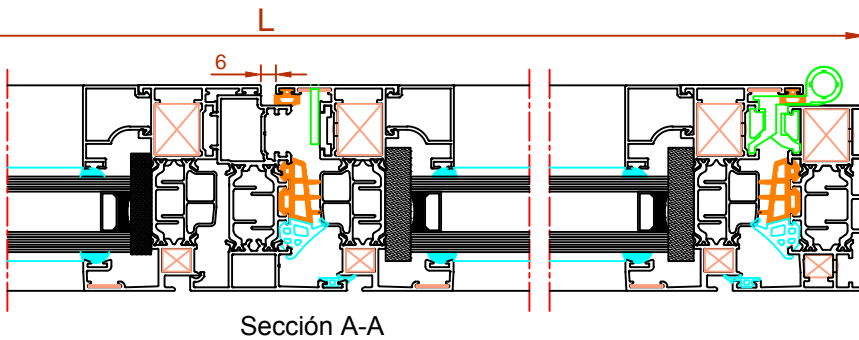



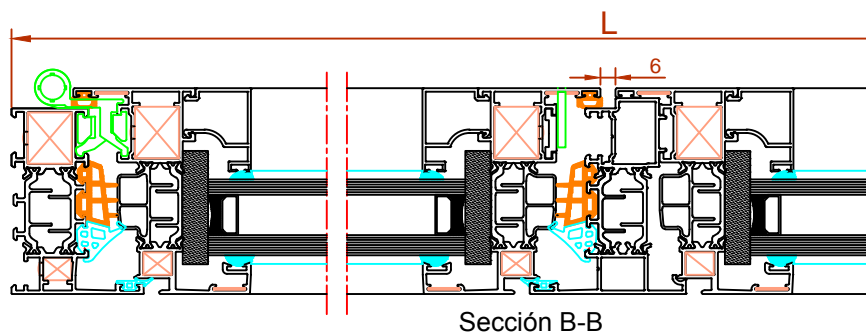
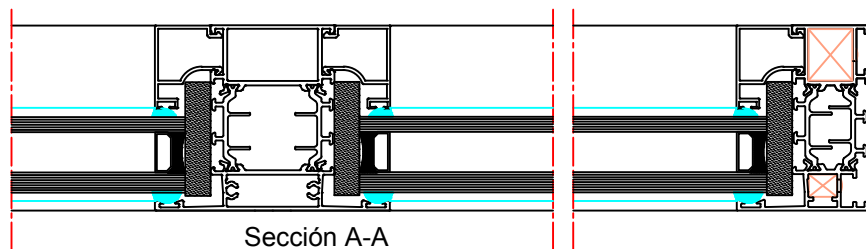
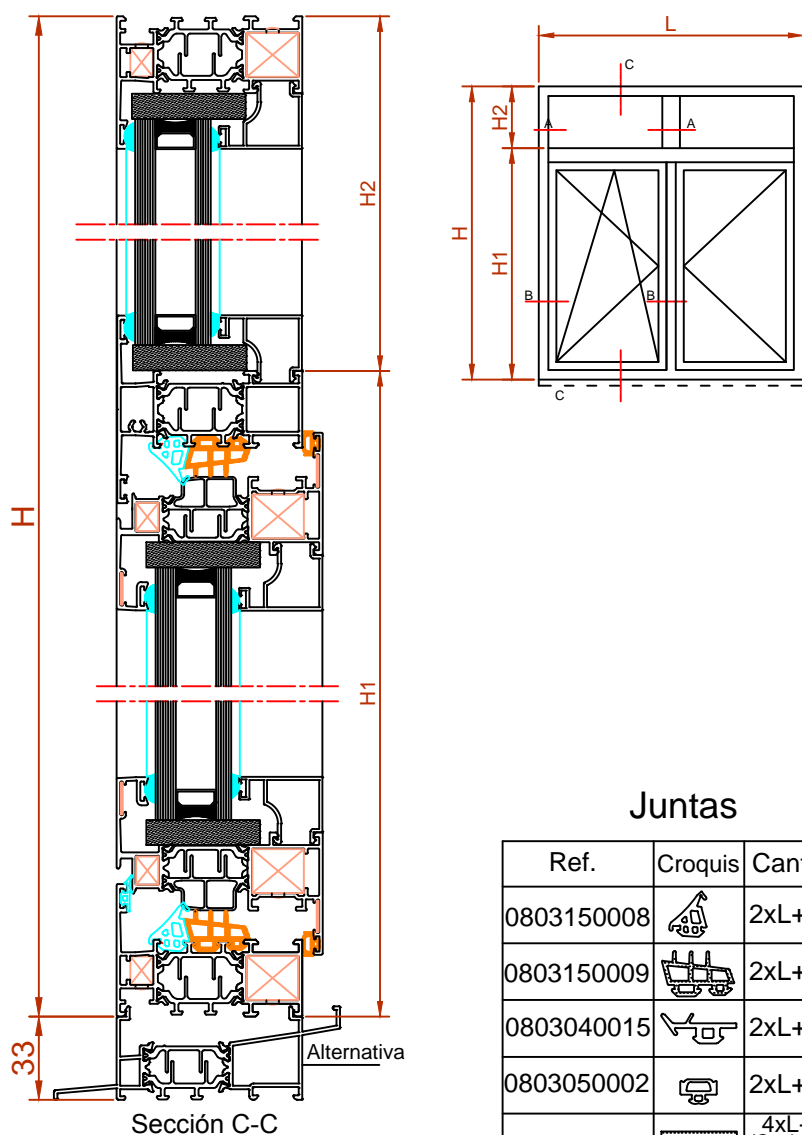















Hojas de corte Ventana apertura interior



RT74 CE - F-i3





PERFILES

Croquis	Referencia	Corte	Medida	Cant.
	74-01		L	2
			H*	2
	74-04		L - 51	1
	74-13		H2 - 20,5	1
	74-02		L/2 - 27,5	4
			H1 - 49*	4
	74-03		H1 - 122*	1
	Según vidrio		L/2-55	2
	S90-50E		H2-75	2
	Según vidrio		L/2-124,5	2
	S90-50E		H1-190*	2
	BX-51		Aprox H/2**	2
	Alternativa *		L	1
	74-05			

* Medida sin condensador; caso de llevarlo reduce la altura 33 mm

** Para ventana practicable; para oscilo. ver pag. F16

Juntas

Ref.	Croquis	Cant.
0803150008		2xL+3xH1
0803150009		2xL+3xH1
0803040015		2xL+3xH1
0803050002		2xL+3xH1
		4xL+4xH (Opcional bajo vidrio)

VIDRIOS

Ancho	Alto	Cant.
L/2-76	H2-52	2
L/2-136	H1-157*	2

ACCESORIOS

Ref.	Descripción	Cant.	
		Pract.	Oscilo.
0302010001	Cremona pract. int.	1	—
0417010001	Kit practicable	1	—
0501010002	Juego pasador prac.	1	—
0602010001	Bisagra practicable der.	2	—
0602010002	Bisagra practicable izq.	2	—
0302010002	Cremona oscilobat.	—	1
0202010001	Cjto. oscilobatiente	—	1
0101010002	Compas oscilo. (s/med.)	—	1
0202010003	Cjto. bisagras simet.	—	1
0501010001	Juego pasador osc.	—	1
0901330002	Juego tapa inversora	1	—
1103170002	Tapa salida agua	2*	(4)
0701070045	Escuadras 17x20	12	—
0701070046	Escuadras 11x9	12	—
0708090001	Escuadras alineami.	16	—
0701070047	Tope travesaño 17	2	—
0701070035	Tope travesaño 36	2	—

Hojas de corte Ventana apertura interior

RT74 CE - F-i4

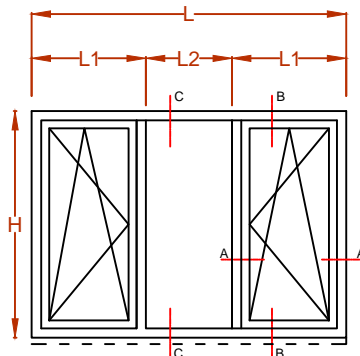
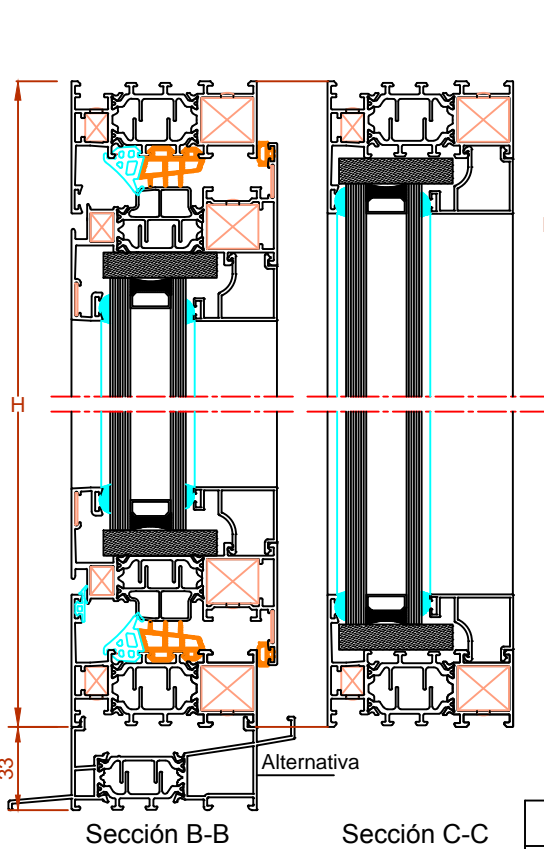

PERFILES

Croquis	Referencia	Corte	Medida	Cant.
	74-01		L	2
			H *	2
	74-04		H - 51 *	2
	74-02		L1 - 49	4
			H - 49 *	4
	Según vidrio		L1-146	4
	S90-50		H-190 *	4
	Según vidrio		L2	2
	S90-50		H-105 *	2
	BX-51		Aprox H/2**	4
	Alternativa *		L	1
	74-05			

* Medida sin condensador; caso de llevarlo reduce la altura 33 mm

** Para ventana practicable; para oscilo. ver pag. Fi6

VIDRIOS

Ancho	Alto	Cant.
L1-157	H-157 *	2
L2-21	H-82 *	1

Para vidrios igual ancho $L1 = L/3 + 45$

Juntas

Ref.	Croquis	Cant.
0803150008		4xL1+4xH
0803150009		4xL1+4xH
0803040015		4xL1+4xH
0803050002		4xL1+4xH
		2xL+6xH (Opcional bajo vidrio)

ACCESORIOS

Ref.	Descripción	Cant.	
		Pract.	Oscilo.
0302010001	Cremona pract. int.	2	—
0417010001	Kit practicable	2	—
0602010001	Bisagra practicable der.	2	—
0602010002	Bisagra practicable izq.	2	—
	Cerradero sup/inf	4	—
0302010002	Cremona oscilobat.	—	2
0202010001	Cjto. oscilobatiante	—	2
0101010002	Compas oscilo. (s/med.)	—	2
1103170002	Tapa salida agua	4* (6)	
0701070045	Escuadras 17x20	12	
0701070046	Escuadras 11x9	12	
0708090001	Escuadras alineami.	16	
0701070047	Tope travesaño 17	4	

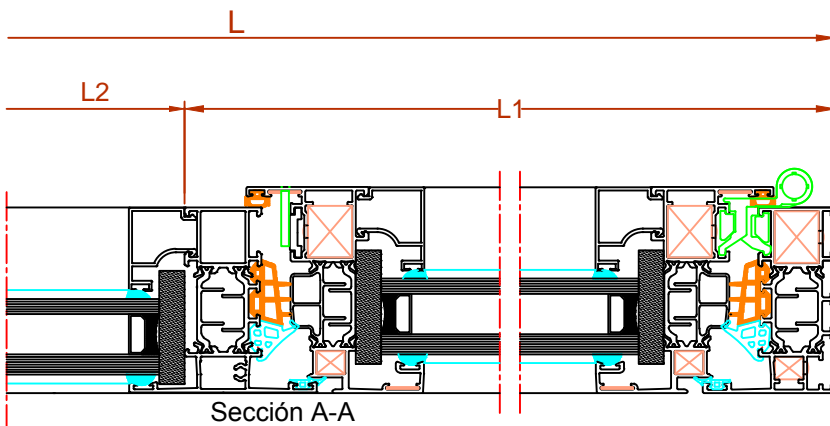





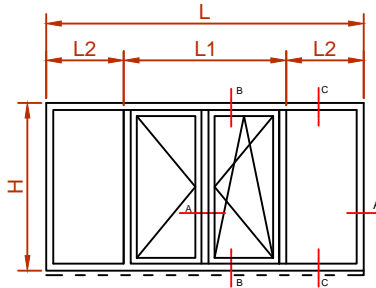
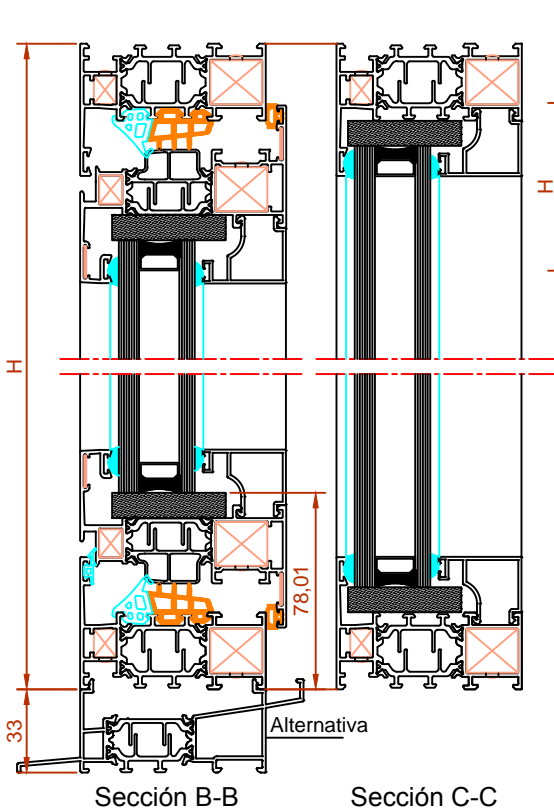











Hojas de corte Ventana apertura interior

RT74 CE - F-i5







PERFILES

Croquis	Referencia	Corte	Medida	Cant.
	74-01		L	2
			H *	2
	74-04		H - 51 *	2
	74-02		L1/2 - 27,5	4
			H - 49 *	4
	74-03		H - 122 *	1
	Según vidrio		L1/2-124,5	4
	S90-50E		H-190 *	4
	Según vidrio		L2-30,5	4
	S9050E		H-105 *	4
	BX-51		Aprox H/2**	4
	Alternativa *		L	1
	74-05			

* Medida sin condensador; caso de llevarlo reduce la altura 33 mm

** Para ventana practicable; para oscilo. ver pag. Fi6

Juntas

Ref.	Croquis	Cant.
0803150008		2xL2+3xH
0803150009		2xL2+3xH
0803040015		2xL2+3xH
0803050002		2xL2+3xH
		2xL+8xH (Opcional bajo vidrio)

VIDRIOS

Ancho	Alto	Cant.
L1 / 2 - 136	H-157 *	2
L2 - 52	H-82 *	2

Para vidrios igual ancho L1= L2+84

ACCESORIOS

Ref.	Descripción	Cant.	
		Pract.	Oscilo.
0302010001	Cremona pract. int.	1	—
0417010001	Kit practicable	1	—
0501010001	Juego pasador prac.	1	—
0602010001	Bisagra practicable der.	2	—
0602010002	Bisagra practicable izq.	2	—
0302010002	Cremona oscilobat.	—	1
0202010001	Cjto. oscilobatiente	—	1
0101010002	Compas oscilo. (s/med.)	—	1
0202010003	Cjto. bisagras simet.	—	1
0501010001	Juego pasador osc.	—	1
0901330002	Juego tapa inversora	1	
1103170002	Tapa salida agua	2*	(4)
0701070045	Escuadras 17x20	12	
0701070046	Escuadras 11x9	12	
0708090001	Escuadras alineami.	16	
0701070047	Tope travesaño 17	4	

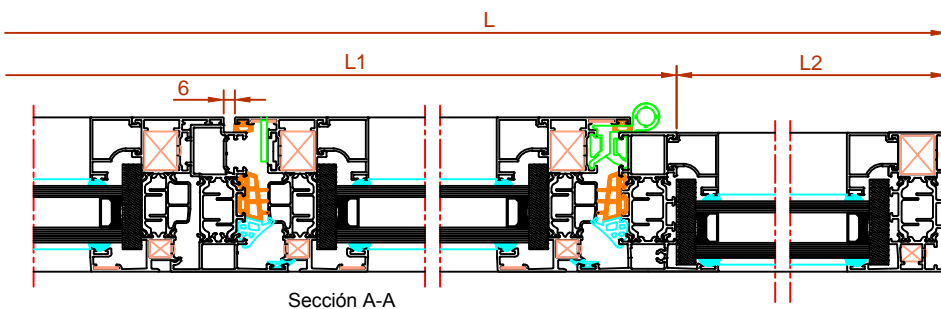

Hojas de corte - Apertura oscilobatiente

RT74 CE - Fi6

CORTE PLETINAS

Ref. 0101010001: Compás pequeño (370 < L < 470): S = L-158

Ref. 0101010002: Compás mediano (471 < L < 580): S = L-396

Ref. 0101010003: Compás grande (581 < L < 1.700): S = L-502



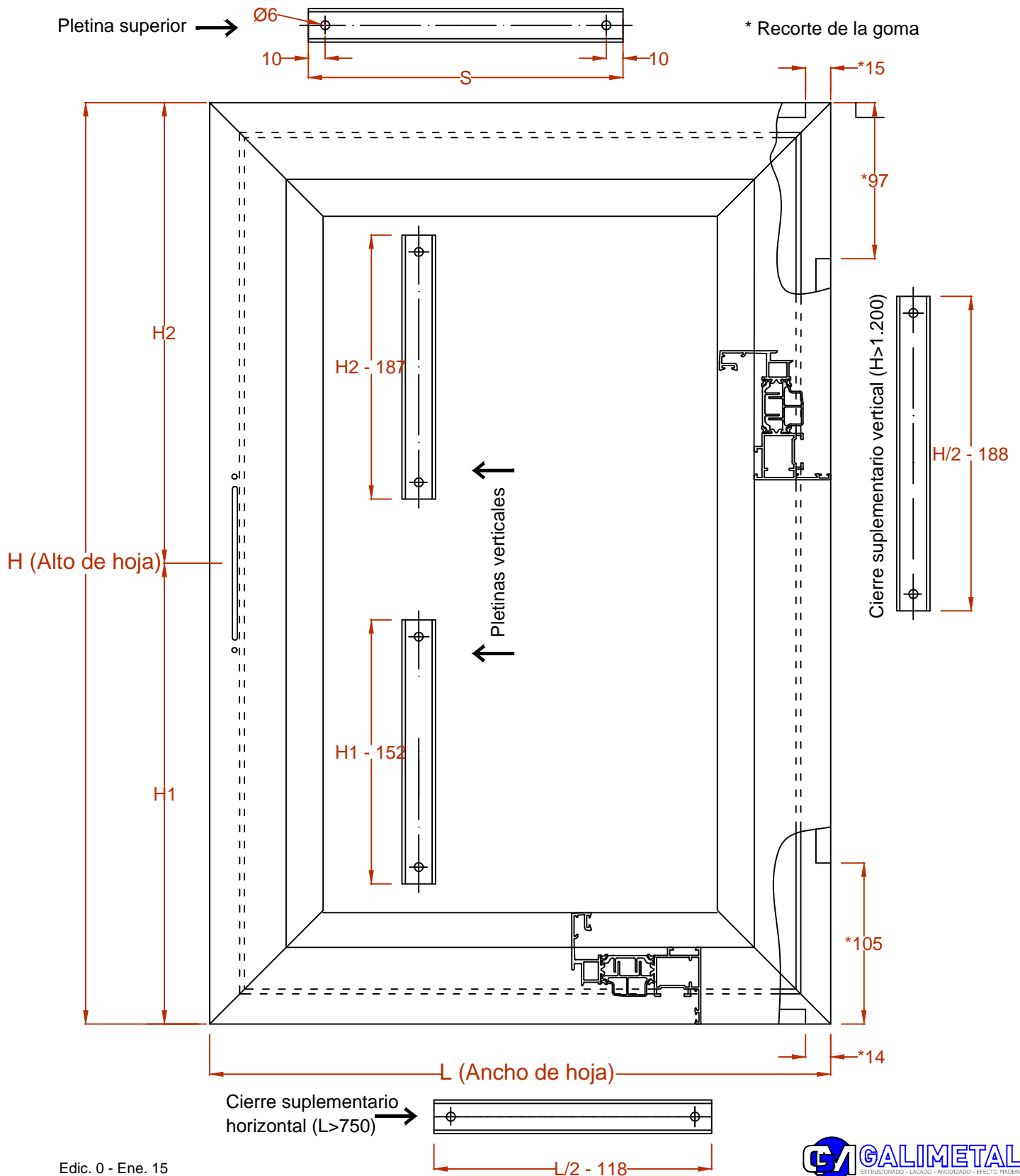







Ref.0101010004: Compas suplementario; (L > 1.000): S = L-608



Hojas de corte Ventana 1 hoja apertura exterior

RT74 CE - F-e1



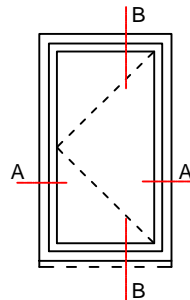
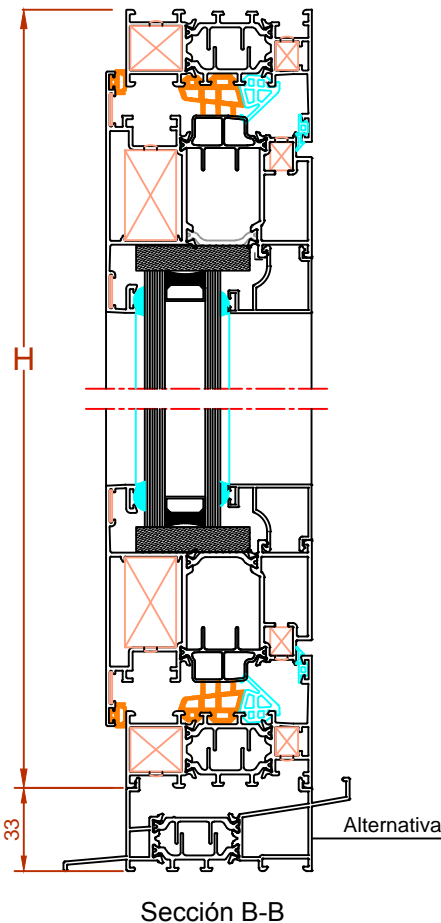

PERFILES

Croquis	Referencia	Corte	Medida	Cant.
	74-01		L	2
			H *	2
	74-11		L - 49	2
			H - 49*	2
	Según vidrio		L-197	2
	S90-50E		H-241*	2
	BX-51		Aprox H/2*	2
	Alternativa *		L	1
	74-05			

* Medida sin condensador; caso de llevarlo reduce la altura 33 mm



Juntas

Ref.	Croquis	Cant.
0803150008		2xL+2xH
0803150009		2xL+2xH
0803040015		2xL+2xH
0803050002		2xL+2xH
		2xL+2xH (Opcional bajo vidrio)

VIDRIOS

Ancho	Alto	Cant.
L-209	H-209 *	1

ACCESORIOS

Ref.	Descripción	Cant.
	Manilla prac. exterior	1
	Caja embutir 40 mm	1
	Terminal pletina	2
060201000 ¹ / ₂	Bisagra practica. ^{Der.} / _{Izq.}	2
1103170002	Tapa salida agua	(*2)
0701070045	Escuadras 17x20	4
0701070048	Escuadras 36x20	4
0701070046	Escuadras 11x9	8
0708090001	Escuadras alineami.	8

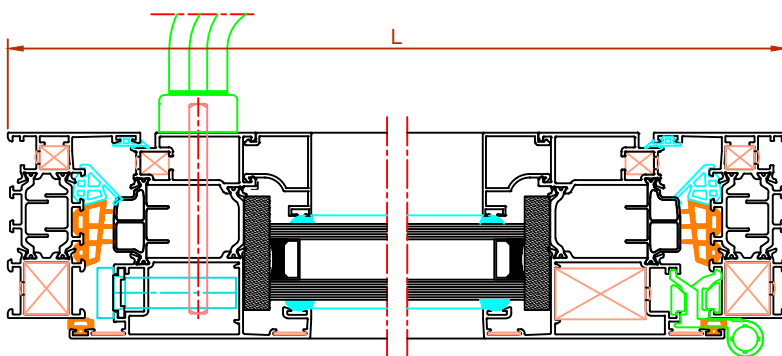





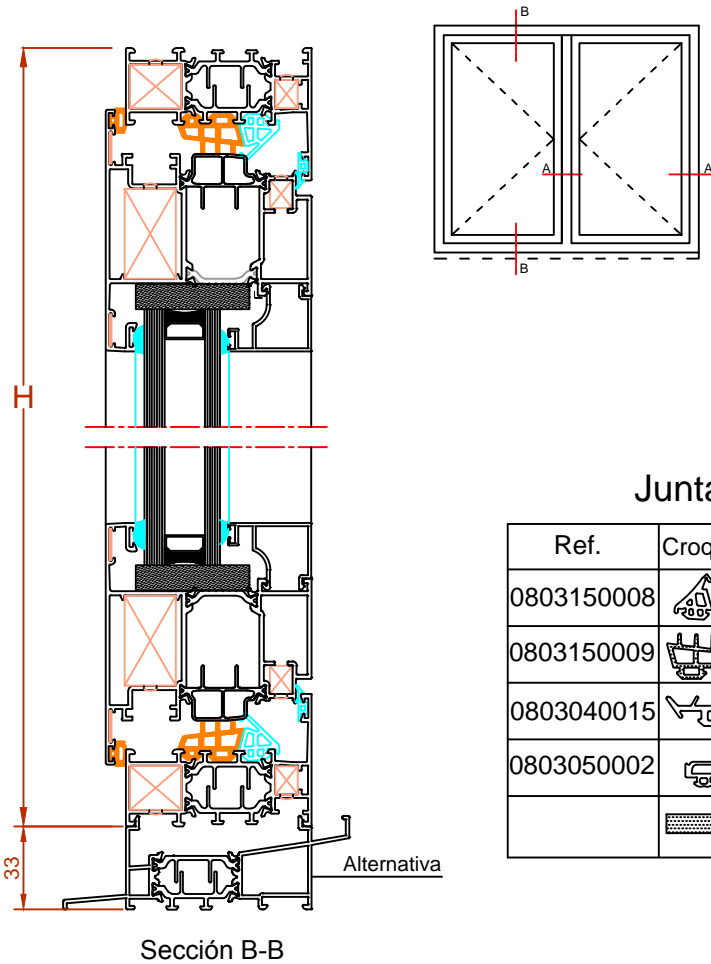







Hojas de corte Ventana 2 hojas apertura exterior

RT74 CE - F-e 2







PERFILES

Croquis	Referencia	Corte	Medida	Cant.
	74-01		L	2
			H *	2
	74-11		L/2 - 27,5	2
			H - 49*	2
	74-03		H - 122*	1
	Según vidrio S90-50E		L/2-175,5	2
			H-241*	2
	BX-51		Aprox H/2*	4
	Alternativa * 74-05		L	1

* Medida sin condensador; caso de llevarlo reduce la altura 33 mm

Juntas

Ref.	Croquis	Cant.
0803150008		2xL+2xH
0803150009		2xL+2xH
0803040015		2xL+2xH
0803050002		2xL+2xH
		2xL+2xH (Opcional bajo vidrio)

VIDRIOS

Ancho	Alto	Cant.
L/2 - 187	H-209*	1

ACCESORIOS

Ref.	Descripción	Cant.
	Manilla prac. exterior	1
	Caja embutir 40 mm	1
	Terminal pletina	2
0501010002	Juego pasador prac.	1
0602010001	Bisagra practicable der.	2
0602010002	Bisagra practicable izq.	2
0901330002	Juego tapa inversora	1
1103170002	Tapa salida agua	(*2)
0701070045	Escuadras 17x20	4
0701070048	Escuadras 36x20	8
0701070046	Escuadras 11x9	12
0708090001	Escuadras alineami.	16

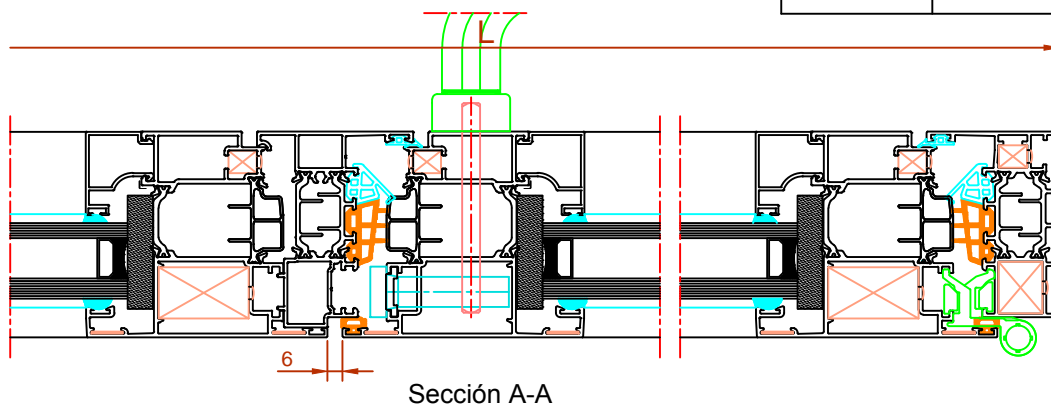

Hojas de corte Ventana apertura exterior

RT74 CE - F-e3

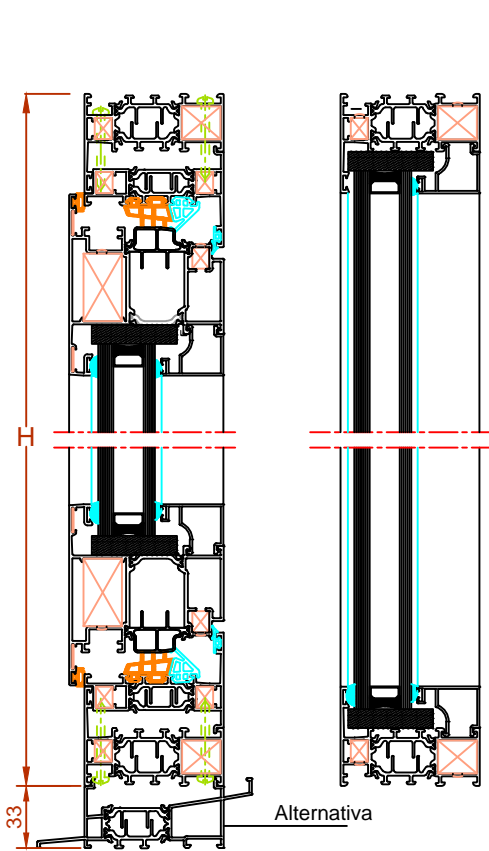





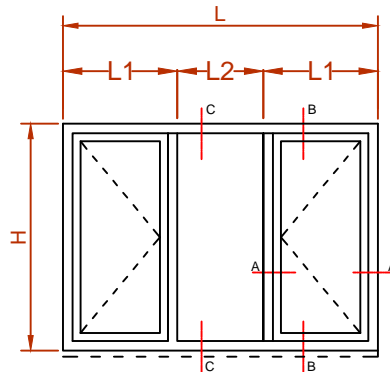











Sección B-B

Sección C-C







PERFILES

Croquis	Referencia	Corte	Medida	Cant.
	74-01		L	2
			H *	2
	74-11		L1 - 106	4
			H - 106*	4
	74-04		H - 51*	1
	74-26		L1 - 55,5	4
			H - 55,5*	4
	Según vidrio		L1-254	4
	S90-50E		H-298*	4
	Según vidrio		L2	2
	S90-50E		H-105*	2
	BX-51		Aprox H/2**	4
	Alternativa *		L	1
	74-05		L	1

* Medida sin condensador; caso de llevarlo reduce la altura 33 mm

Juntas

Ref.	Croquis	Cant.
0803150008		4xL1+4xH
0803150009		4xL1+4xH
0803040015		4xL1+4xH
0803050002		4xL1+4xH
		2xL+6xH (Opcional bajo vidrio)

VIDRIOS

Ancho	Alto	Cant.
L1-266	H-266 *	2
L2-21	H-82 *	1

Para vidrios igual ancho L1= L/3+82

ACCESORIOS

Ref.	Descripción	Cant.
	Manilla prac. exterior	2
	Caja embutir 40 mm	2
	Terminal pletina	4
0602010001	Bisagra practicable der.	2
0602010002	Bisagra practicable izq.	2
1103170002	Tapa salida agua	(*2)
0701070045	Escuadras 17x20	4
0701070048	Escuadras 36x20	8
0701070046	Escuadras 11x9	28
0708090001	Escuadras alineami.	16
0701070047	Tope travesaño 17	4

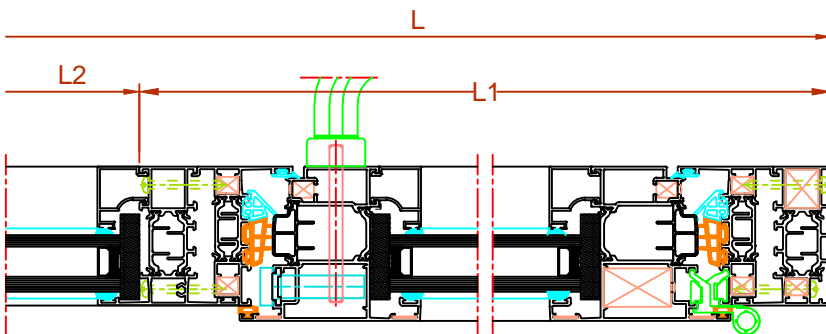

Hojas de corte Ventana apertura exterior

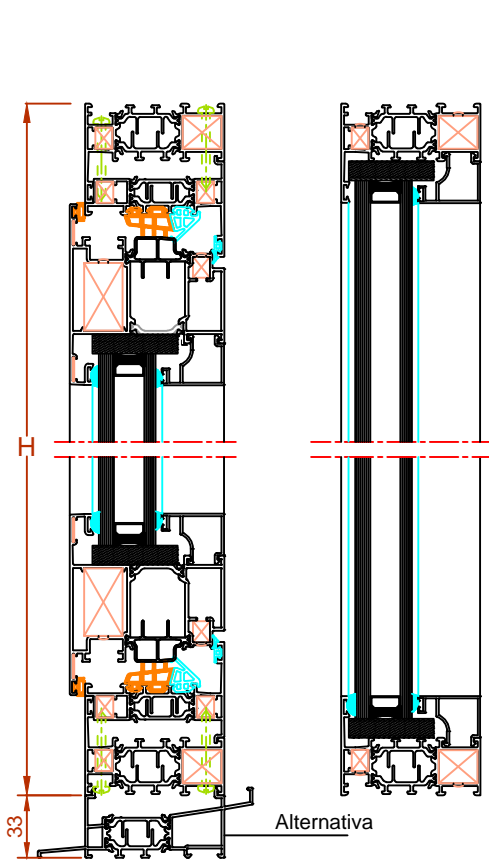

Sección B-B

Sección C-C

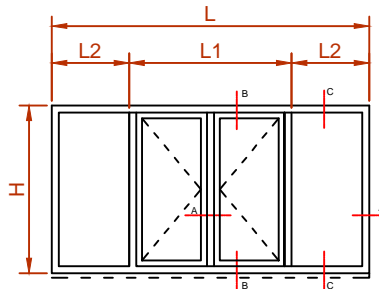

PERFILES

RT74 CE - F-e4

Croquis	Referencia	Corte	Medida	Cant.
	74-01		L	2
			H *	2
	74-11		L1 / 2 - 56	4
			H - 106*	4
	74-04		H - 51*	2
	74-26		L1 - 55,5	2
			H - 55,5*	2
	Según vidrio		L1 / 2 - 204	4
	S90-50E		H-298 *	4
	Según vidrio		L2 - 30,5	4
	S90-50E		H-105 *	4
	BX-51		Aprox H/2**	2
	Alternativa *		L	1
	74-05			

* Medida sin condensador; caso de llevarlo reduce la altura 33 mm

VIDRIOS

Ancho	Alto	Cant.
L1 / 2 - 216	H-266 *	2
L2 - 52	H-82 *	1

Para vidrios igual ancho L1= L/2 + 164

Juntas

Ref.	Croquis	Cant.
0803150008		2xL1+3xH
0803150009		2xL1+3xH
0803040015		2xL1+3xH
0803050002		2xL1+3xH
		2xL+8xH (Opcional bajo vidrio)

ACCESORIOS



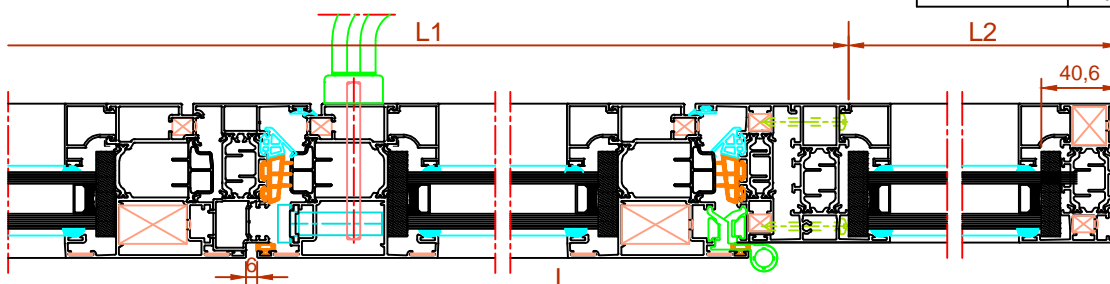







Ref.	Descripción	Cant.
	Manilla prac. exterior	1
	Caja embutir 40 mm	1
	Terminal pletina	2
0501010002	Juego pasador	1
0602010001	Bisagra practicable der.	2
0602010002	Bisagra practicable izq.	2
0901330002	Juego tapa inversora	1
1103170002	Tapa salida agua	(*2)
0701070045	Escuadras 17x20	4
0701070048	Escuadras 36x20	8
0701070046	Escuadras 11x9	20
0708090001	Escuadras alineami.	16
0701070047	Tope travesaño 17	4



Hojas de corte Ventana apertura P.D.

RT74 CE - F-e5



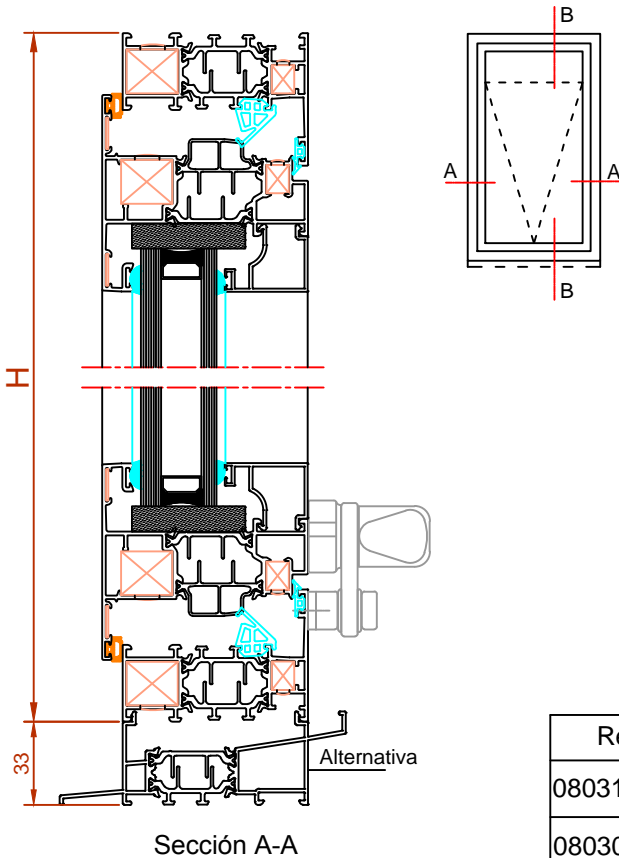

PERFILES

Croquis	Referencia	Corte	Medida	Cant.
	74-01		L	2
			H *	2
	74-25		L - 49	2
			H - 49*	2
	Según vidrio		L-161	2
	S90-50E		H-205*	2
	GALI-1022		600	2
	Alternativa *		L	1
	74-05			

* Medida sin condensador; caso de llevarlo reduce la altura 33 mm



Juntas

Ref.	Croquis	Cant.
0803150008		2xL+2xH
0803040015		2xL+2xH
0803050002		2xL+2xH
		2xL+2xH (Opcional bajo vidrio)

VIDRIOS

Ancho	Alto	Cant.
L-172	H-172 *	1

ACCESORIOS



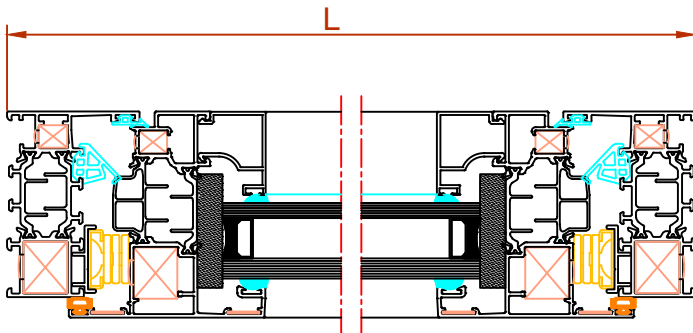









Ref.	Descripción	Cant.
	Cierre presión	1
	Compas P.D. (juego)	1
1103170002	Tapa salida agua	(*2)
0701070045	Escuadras 17x20	8
0701070046	Escuadras 11x9	8
0708090001	Escuadras alineami.	8



Hojas de corte Balconera 2 hojas apertura interior





RT74 CE - F-Bi1

PERFILES

Croquis	Referencia	Corte	Medida	Cant.
	74-01		L	2
			H	2
	74-02		L/2 - 27,5	4
			H - 49	4
	74-04		L/2-114,5	2
	74-03		H - 122	1
	Según vidrio S90-50E		L/2-124,5	8
			H1-108	4
			H2-108	4
	BX-51		Aprox H/2*	2

* Para ventana practicable; para oscilo. ver pag. Fi6

Juntas

Ref.	Croquis	Cant.
0803150008		2xL+3xH
0803150009		2xL+3xH
0803040015		2xL+3xH
0803050002		2xL+3xH
		4xL+4xH (Opcional bajo vidrio)

VIDRIOS

Ancho	Alto	Cant.
L/2-136	H1-80	2
L/2-136	H2-80	2

ACCESORIOS

Ref.	Descripción	Cant.	
		Pract.	Oscilo.
0302010001	Cremona pract. int.	1	—
0417010001	Kit practicable	1	—
0501010002	Juego pasador prac.	1	—
0602010001	Bisagra practicable der.	3	—
0602010002	Bisagra practicable izq.	3	—
0302010002	Cremona oscilobat.	—	1
0202010001	Cjto. oscilobatiente	—	1
0101010002	Compas oscilo. (s/med.)	—	1
0202010003	Cjto. bisagras simet.	—	1
0501010001	Juego pasador osc.	—	1
	Cierre suplem. vertic.	—	1(2)**
	Cierre central oculto	—	1(2)**
0901330002	Juego tapa inversora	1	
1103170002	Tapa salida agua	2 (4)	
0701070045	Escuadras 17x20	12	
0701070046	Escuadras 11x9	12	
0708090001	Escuadras alineami.	16	
0701070047	Tope travesaño 17	2	

** Ver "Fabricación"; pag. H4

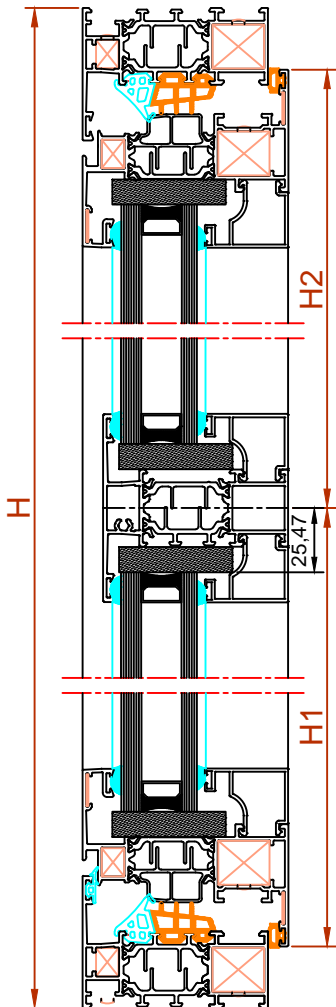

Sección B-B

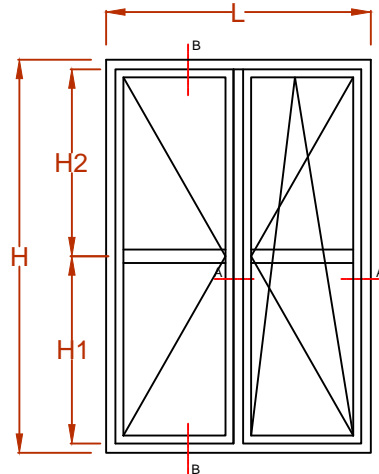



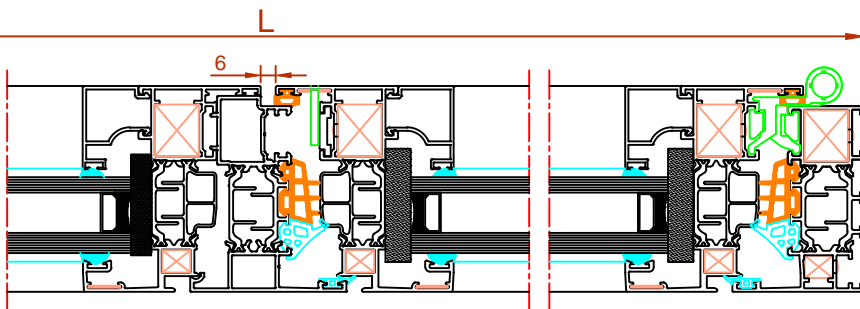









Sección A-A



Hojas de corte - Apertura interior Plegable; esquema 330

RT74 CE - F-Bi2/A

PERFILES

Croquis	Referencia	Corte	Medida	Cant.
	74-14		L	2
			H-50	2
	74-15		L/3 - 5,5	4
			L/3 - 87,5	2
			H - 136,5	6
	74-03		H - 209,5	2
	Según vidrio S90-50		L/3-151,5	4
			L/3-233,5	2
			H-326,5	6
	BX-51		Aprox H/2**	4
	74-28		L	2

VIDRIOS



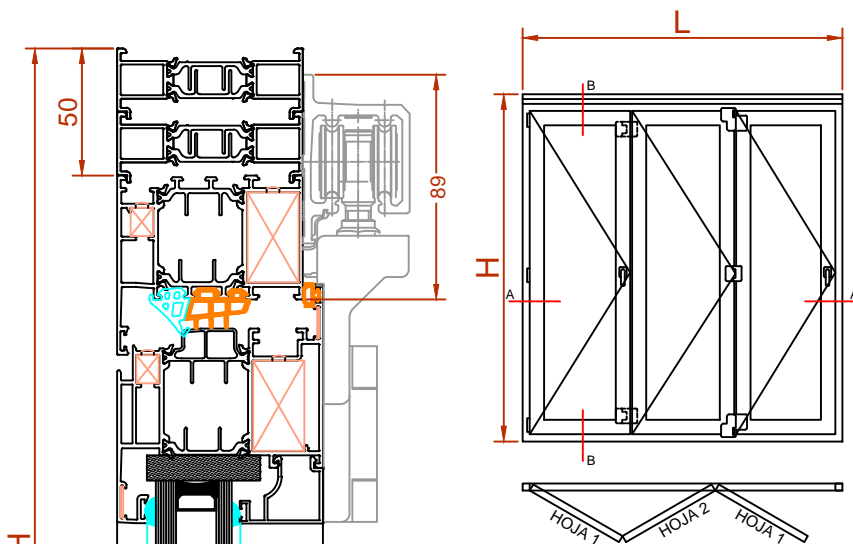

Ancho	Alto	Cant.
L/3-162	H-293	2
L/3-245	H-293	1

ACCESORIOS

Ref.	Descripción	Cant.
	Kit plegable 330	1
060201000 ¹ / ₂	Bisagra practicable ^{der.} _{l.zq.}	3
0302010001	Cremona practicable	2
0901330002	Juego tapa inversora	2
1103170002	Tapa salida agua	4
0701070048	Escuadras 36x20	16
0701070046	Escuadras 11x9	16
0708090001	Escuadras alineami.	24



Juntas

Ref.	Croquis	Cant.
0803150008		2xL+4xH
0803150009		2xL+4xH
0803040015		2xL+4xH
0803050002		2xL+4xH
		2xL+6xH (Opcional bajo vidrio)

Sección B-B

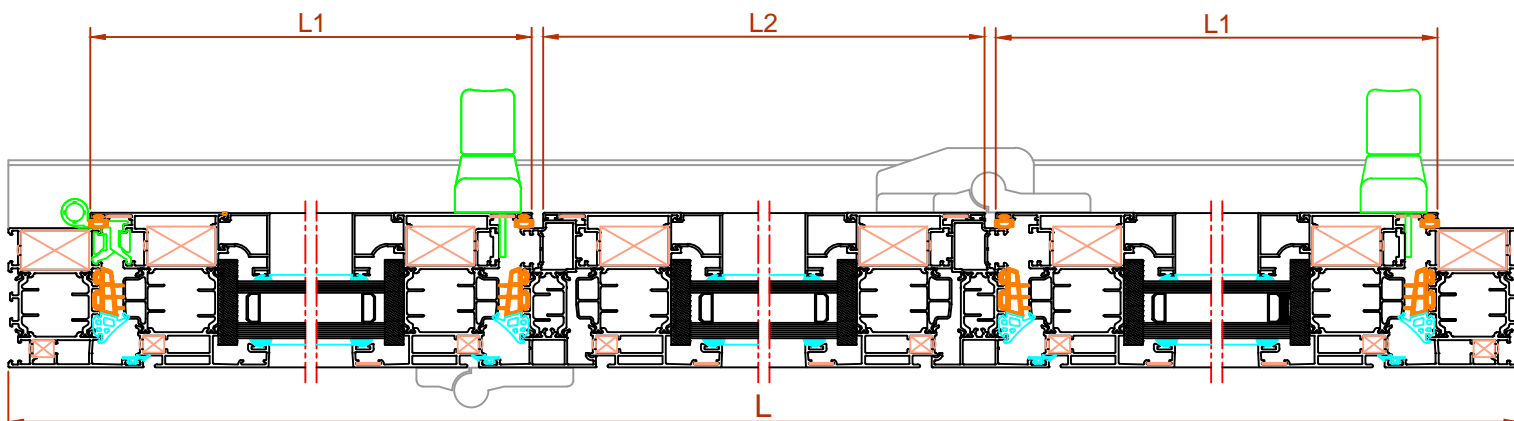

Sección A-A

Hojas de corte - Apertura interior Plegable; cortes horizontales

RT74 CE - F-Bi2/B

Con marcos laterales 74-14

Esquema 330

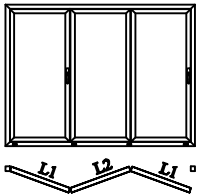

Esquema 321

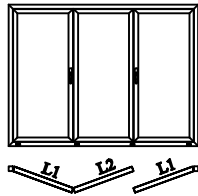

Esquema 431

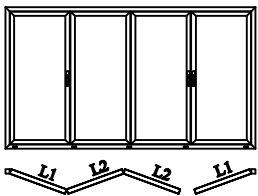

Ref. kit plegable	Corte hoja horizontal			
	Esquema	L1	L2	L3
330		L/3 - 5,5	L/3 - 87,5	—
321		L/3 - 5,5	L/3 - 87,5	—
431		L/4 + 15	L/4 - 67	—
550		L/5 + 13	L/5 - 69	L/5 + 1
541		L/5 + 13	L/5 - 69	L/5 + 1
532		L/5 + 13	L/5 - 69	L/5 + 1
651		L/6 + 12	L/5 - 70	L/6
633		L/6 + 12	L/6 - 70	L/6
770		L/7 + 21	L/7 - 61	L/7+9
761		L/7 + 21	L/7 - 61	L/7+9
743		L/7 + 21	L/7 - 61	L/7+9

Esquema 550

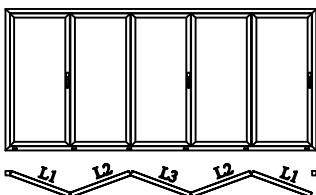

Esquema 541

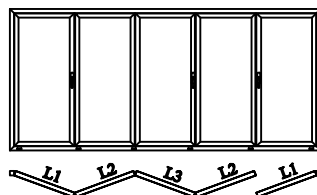

Esquema 532

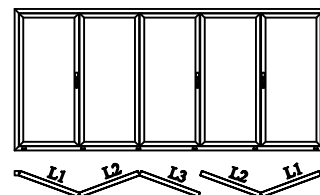

Esquema 651

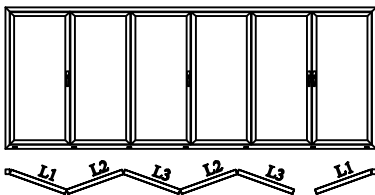

Esquema 633

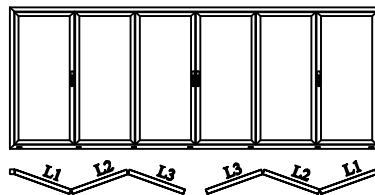

Máx. por hoja

- Ancho: 900 mm
- Alto: 2.400 mm
- Peso: 80 kg

Esquema 770

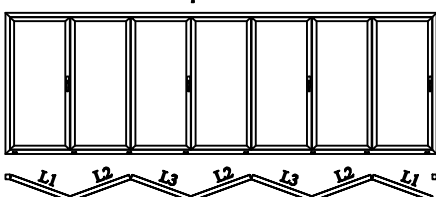

Esquema 761

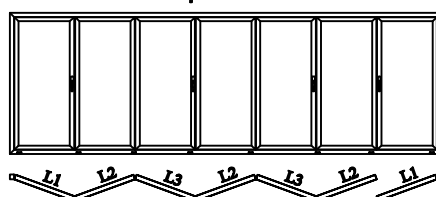

Esquema 743

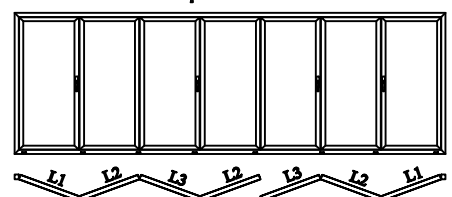

Hojas de corte Osciloparalela 1 hoja

RT74 CE - F-Bi3

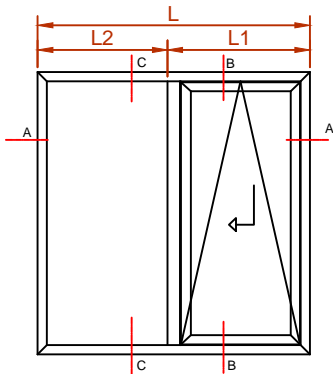

Juntas

Ref.	Croquis	Cant.
0803150008		2xL1+2xH
0803150009		2xL1+2xH
0803040015		2xL1+2xH
0803050002		2xL1+2xH
		2xL+4xH (Opcional bajo vidrio)

PERFILES

Croquis	Referencia	Corte	Medida	Cant.
	74-14		L	2
			H - 5	2
	74-15		L1 - 86,5	2
			H - 91,5	2
	74-13		H - 93,5	1
	Según vidrio		L1 - 232	2
	S90-50		H - 281,5	2
	Según vidrio		L2 - 49	2
	S90-50		H - 147,5	2
Ple. 25x5			L	2

VIDRIOS

Ancho	Alto	Cant.
L1 - 243	H - 248	1
L2 - 70	H - 124	1

Para vidrios igual ancho $L1 = L/2 + 86,5$

ACCESORIOS

Ref.	Descripción	Cant.
$\frac{1}{2}$	Kit paralela esq. A ^{der.} / _{lq.}	1
	Juego guías paralela	1
	Cremona int. paralela	1
	Ceraderos	3
1103170002	Tapa salida agua	2
0701070048	Escuadras 36x20	8
0701070046	Escuadras 11x9	8
0708090001	Escuadras alineami.	8
0701070035	Tope travesaño 36	2

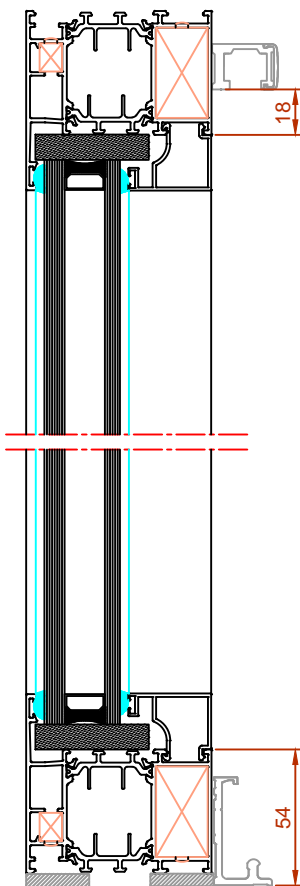

Sección C-C

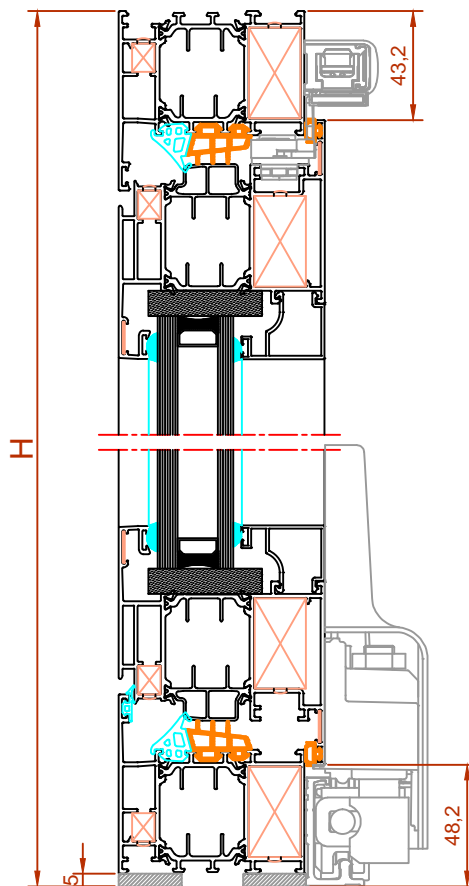

Sección B-B

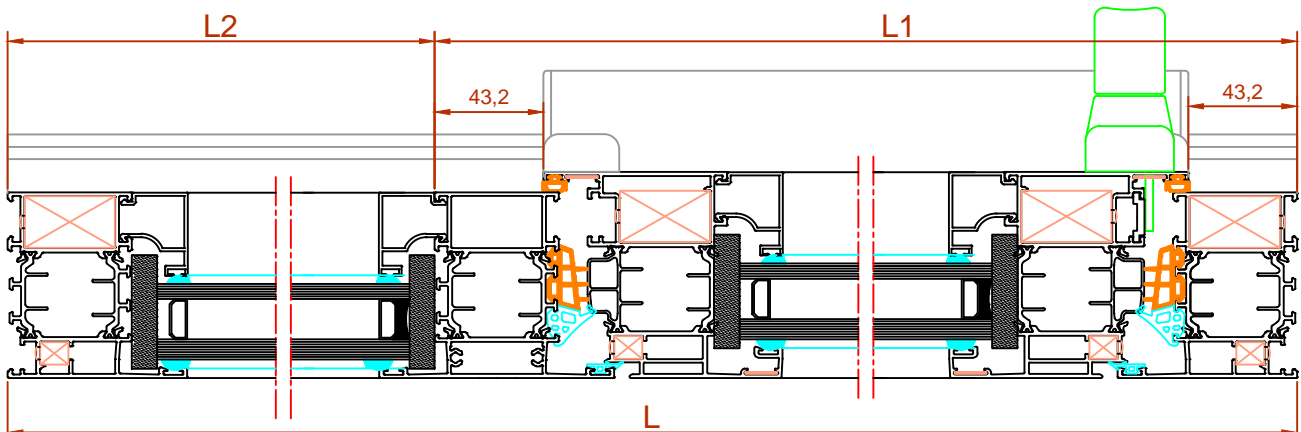

Sección A-A





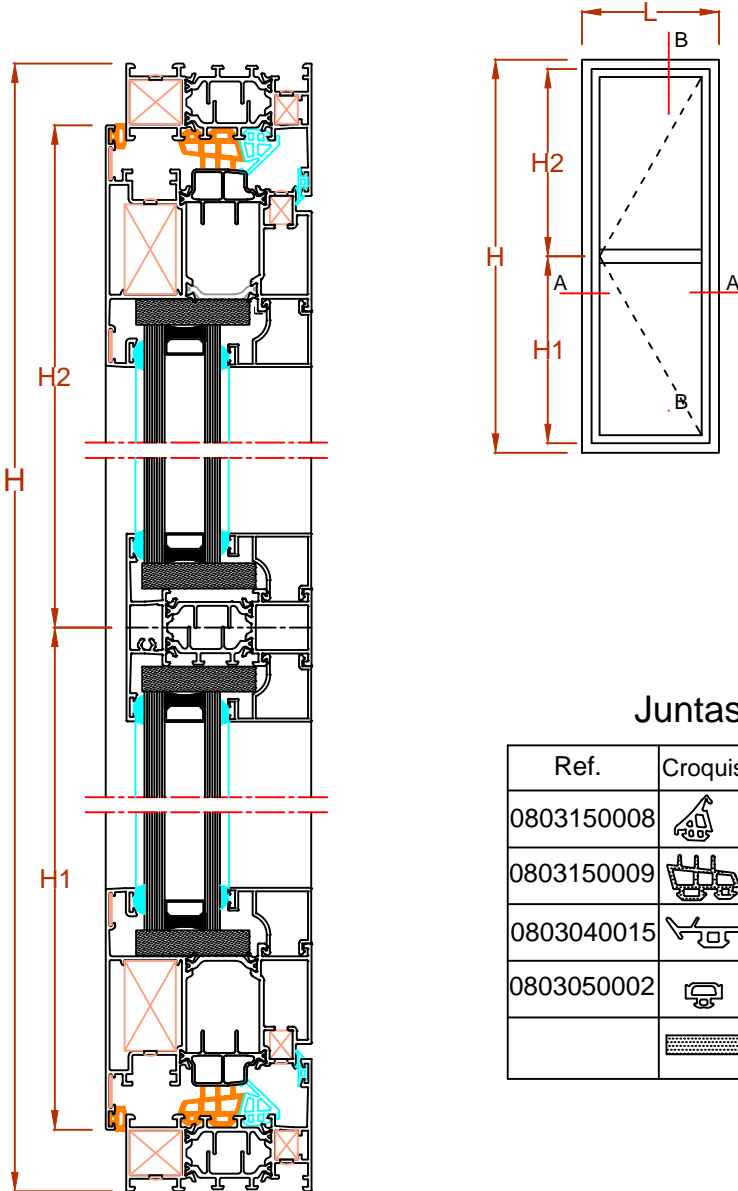





Hojas de corte Balconera apertura exterior

RT74 CE - F-Be1







Sección B-B

PERFILES

Croquis	Referencia	Corte	Medida	Cant.
	74-01		L	2
			H	2
	74-11		L - 49	2
			H - 49	2
	74-04		L - 187	1
	Según vidrio S90-50		L-197	4
			H1 - 133	2
			H2 - 133	2
	BX-51		Aprox H/2*	2

Juntas

Ref.	Croquis	Cant.
0803150008		2xL+2xH
0803150009		2xL+2xH
0803040015		2xL+2xH
0803050002		2xL+2xH
		4xL+2xH (Opcional bajo vidrio)

VIDRIOS

Ancho	Alto	Cant.
L-209	H1 - 106	1
L-209	H2 - 106	1

ACCESORIOS

Ref.	Descripción	Cant.
	Manilla prac. exterior	1
	Caja embutir 40 mm	1
	Terminal pletina	2
060201000 ¹ / ₂	Bisagra practica. ^{Der.} / _{Izg.}	3
0701070045	Escuadras 17x20	4
0701070048	Escuadras 36x20	4
0701070046	Escuadras 11x9	8
0708090001	Escuadras alineami.	8
0701070047	Tope travesaño 17	2

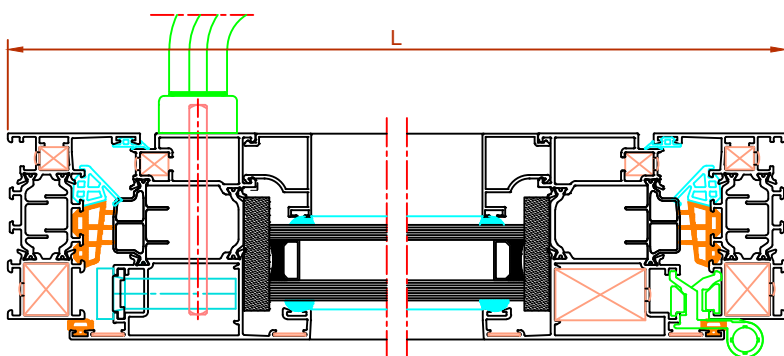











Sección A-A

Hojas de corte Puerta entrada apertura interior

RT74 CE - F-Pi1





PERFILES

Croquis	Referencia	Corte	Medida	Cant.
	74-14		L	1
			H+60	2 (1+1)
	74-15		L - 87	1
			H - 50	2 (1+1)
	74-16		L-222	2
	Según vidrio S90-50E		L-232	5
			H1-180	4
			H2-155	4

VIDRIOS

Ancho	Alto	Cant.
L-243	H1-158	1
L-243	H2-127	1

Juntas

Ref.	Croquis	Cant.
0803150008		L+2xH
0803150009		L+2xH
0803040015		L+2xH
0803050002		L+2xH
		4xL+2xH (Opcional bajo vidrio)

ACCESORIOS

Ref.	Descripción	Cant.
	Cerradura 3 puntos	1
	Cerradero central	1
	Cerradero sup/inf.	2
	Bombillo doble 30x70	1
	Manilla P.E. doble	1
060201000	1/2 Bisagra practicable <small>Der. Izq.</small>	4
0701070048	Escuadras 36x20	4
0701070046	Escuadras 11x9	4
0708090001	Escuadras alineami.	4

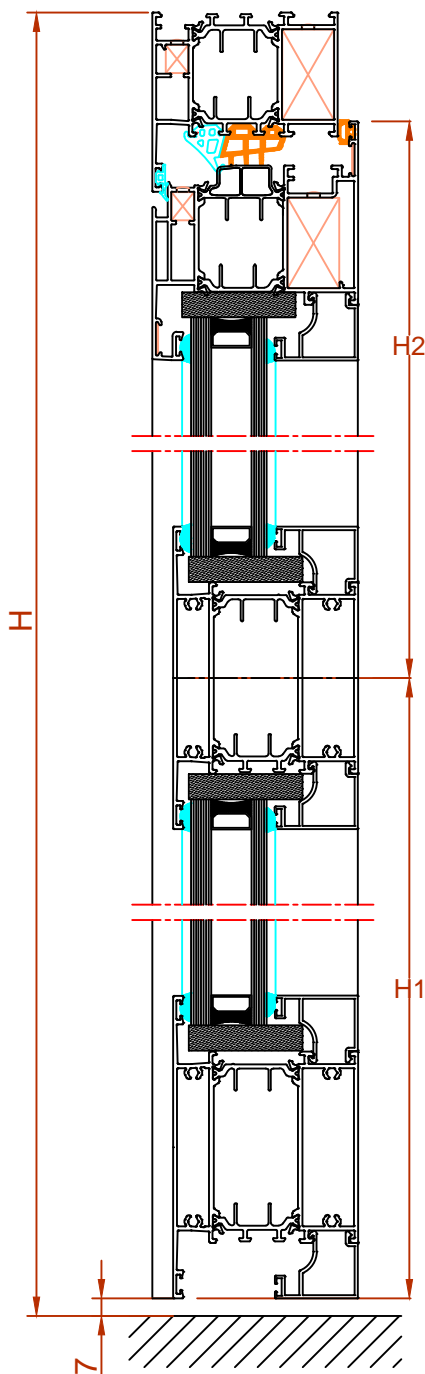

Sección B-B

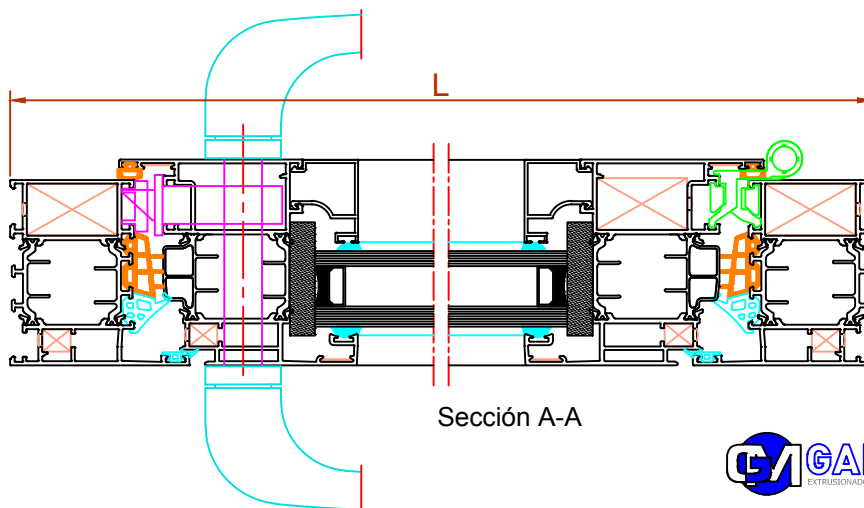
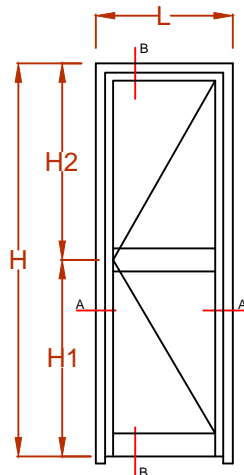











Sección A-A

Hojas de corte Puerta entrada apertura interior

RT74 CE - F-Pi2





PERFILES

Croquis	Referencia	Corte	Medida	Cant.
	74-14		L	1
	74-15		H+60	2 (1+1)
			H - 50	4 (2+2)
	74-16		L/2-182	4
	74-03		H - 86,5	1
	Según vidrio S90-50E		L/2-192	10
			H1-180	4
			H2-155	4

VIDRIOS

Ancho	Alto	Cant.
L/2-203	H1-158	2
L/2-203	H2-127	2

Juntas

Ref.	Croquis	Cant.
0803150008		L+3xH
0803150009		L+3xH
0803040015		L+3xH
0803050002		L+3xH
		4xL+4xH (Opcional bajo vidrio)

ACCESORIOS

Ref.	Descripción	Cant.
	Cerradura 3 puntos	1
	Cerradero central	1
	Cerradero sup/inf.	2
	Bombillo doble 30x70	1
	Manilla P.E. doble	1
0501010002	Juego pasador prac.	1
0602010001	Bisagra practicable der.	4
0602010002	Bisagra practicable izq.	4
0901330002	Juego tapa inversora	1
0701070048	Escuadras 36x20	6
0701070046	Escuadras 11x9	6
0708090001	Escuadras alineami.	8

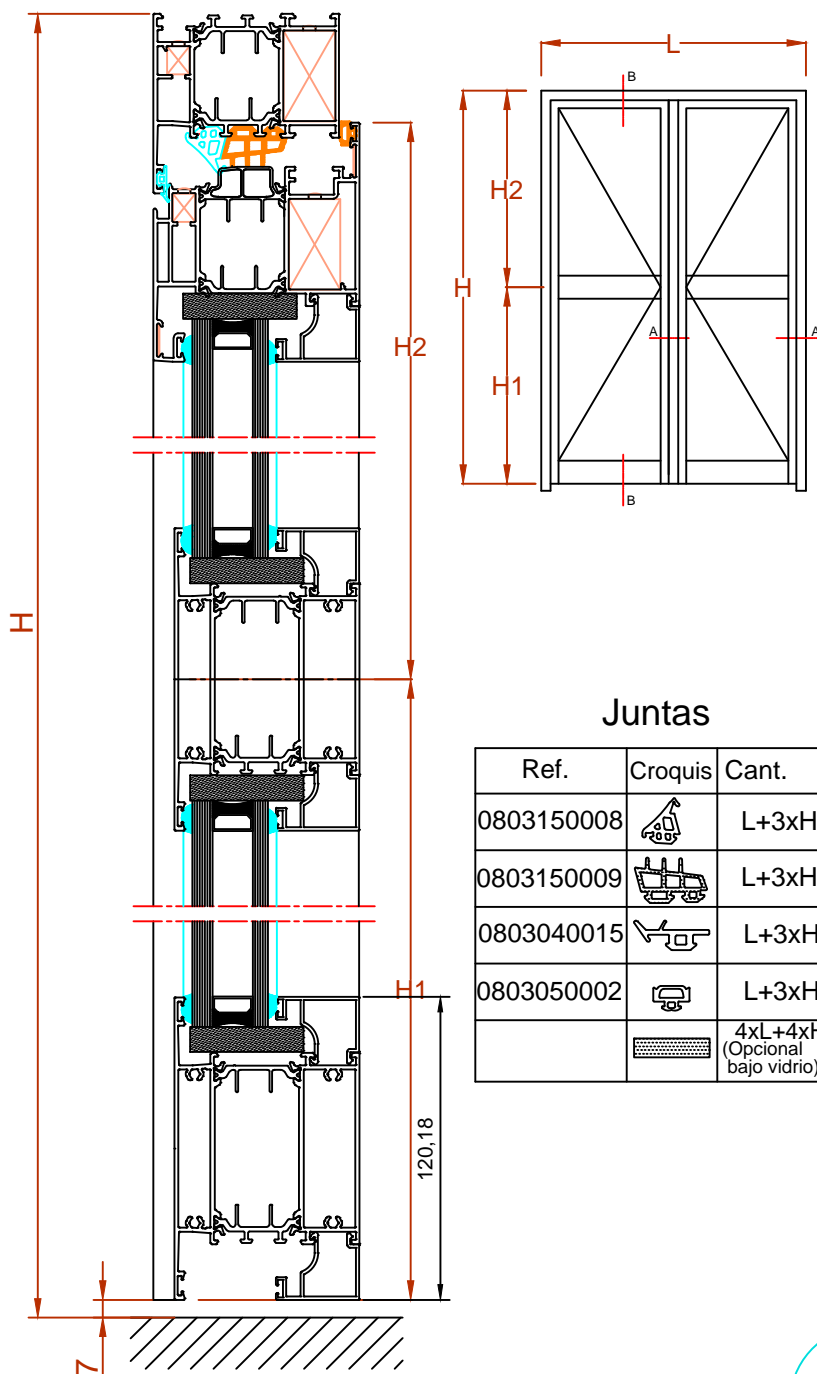

Sección B-B

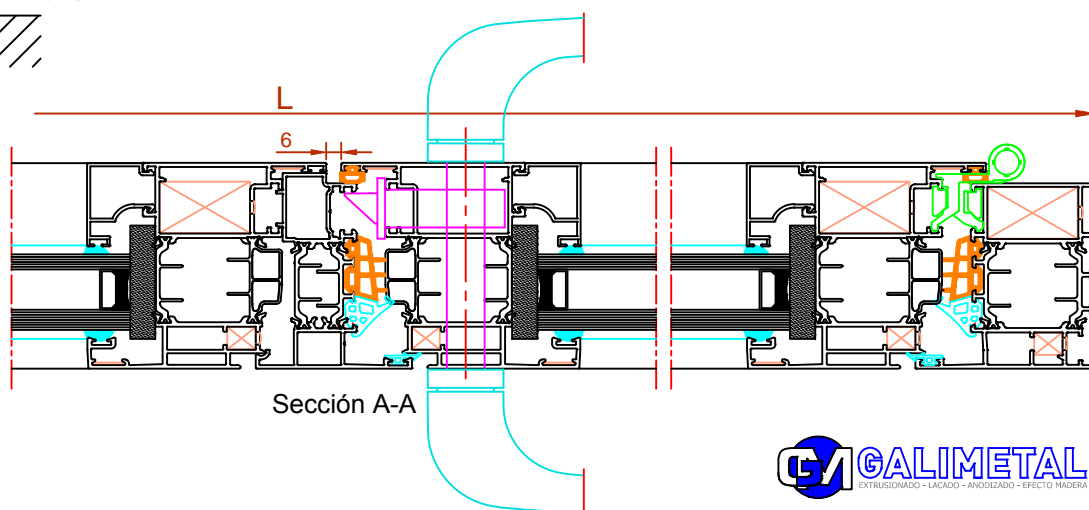











Sección A-A

Hojas de corte Puerta entrada apertura exterior

RT74 CE - F-Pe1





PERFILES

Croquis	Referencia	Corte	Medida	Cant.
	74-14		L	1
			H+60	2 (1+1)
	74-11		L - 87	1
			H - 50	2 (1+1)
	74-16		L-224	2
	Según vidrio S90-50E		L-234	5
			H1-180	2
			H2-156	2

VIDRIOS

Ancho	Alto	Cant.
L-245	H1-158	2
L-245	H2-128	2

Juntas

Ref.	Croquis	Cant.
0803150008		L+2xH
0803150009		L+2xH
0803040015		L+2xH
0803050002		L+2xH
		4xL+2xH (Opcional bajo vidrio)

ACCESORIOS

Ref.	Descripción	Cant.
	Cerradura 3 puntos	1
	Cerradero central	1
	Cerradero sup/inf.	2
	Bombillo doble 30x70	1
	Manilla P.E. doble	1
060201000 1/2	Bisagra practicable ^{Der.} / _{Izq.}	4
0701070048	Escuadras 36x20	4
0701070046	Escuadras 11x9	4
0708090001	Escuadras alineami.	4

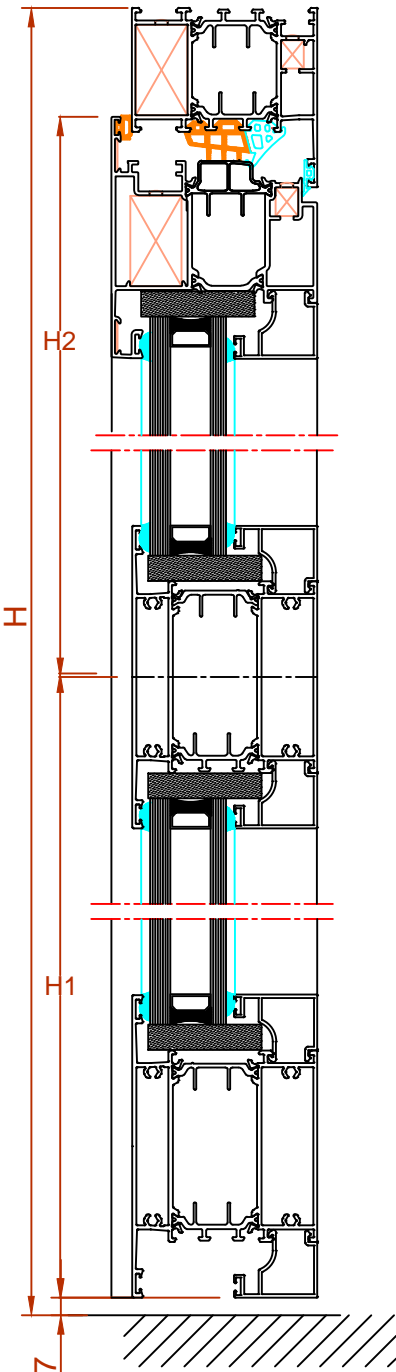

Sección B-B

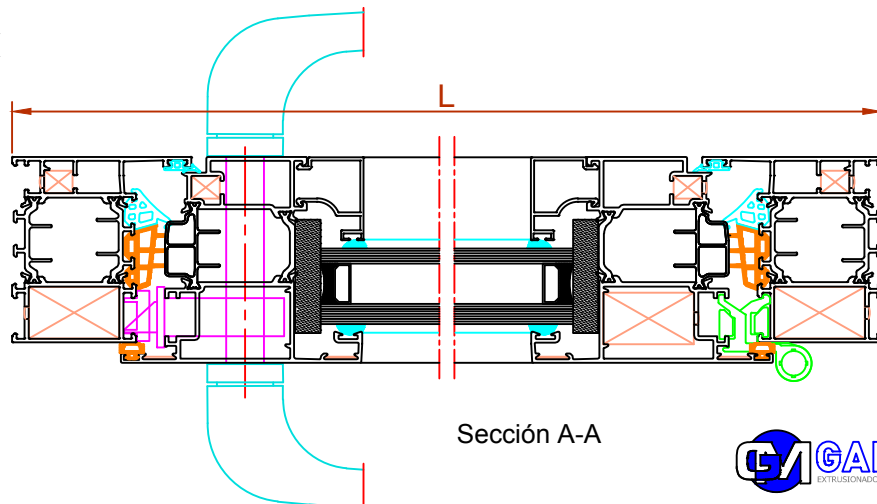
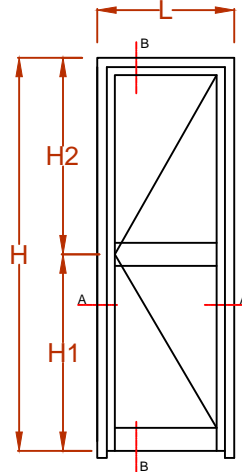













Sección A-A

Hojas de corte Puerta entrada apertura exterior

RT74 CE - F-Pe2





PERFILES

Croquis	Referencia	Corte	Medida	Cant.
	74-14		L	1
			H+60	2 (1+1)
	74-11		L/2 - 46,5	2
			H - 50	4 (2+2)
	74-16		L/2-184	4
	74-03		H - 86,5	1
	Según vidrio S90-50E		L/2-194	10
			H1-180	4
			H2-156	4

VIDRIOS

Ancho	Alto	Cant.
L/2-206	H1-158	2
L/2-206	H2-128	2

Juntas

Ref.	Croquis	Cant.
0803150008		L+3xH
0803150009		L+3xH
0803040015		L+3xH
0803050002		L+3xH
		4xL+4xH (Opcional bajo vidrio)

ACCESORIOS

Ref.	Descripción	Cant.
	Cerradura 3 puntos	1
	Cerradero central	1
	Cerradero sup/inf.	2
	Bombillo doble 30x70	1
	Manilla P.E. doble	1
0501010002	Juego pasador prac.	1
0602010001	Bisagra practicable der.	4
0602010002	Bisagra practicable izq.	4
0901330002	Juego tapa inversora	1
0701070048	Escuadras 36x20	6
0701070046	Escuadras 11x9	6
0708090001	Escuadras alineami.	8

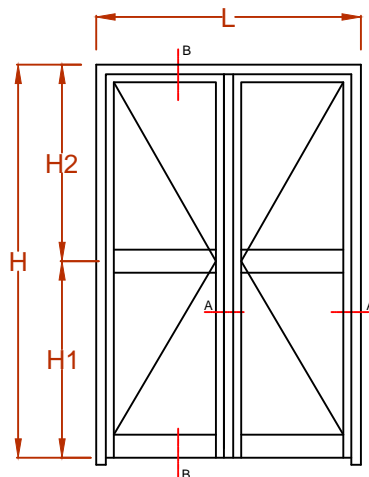
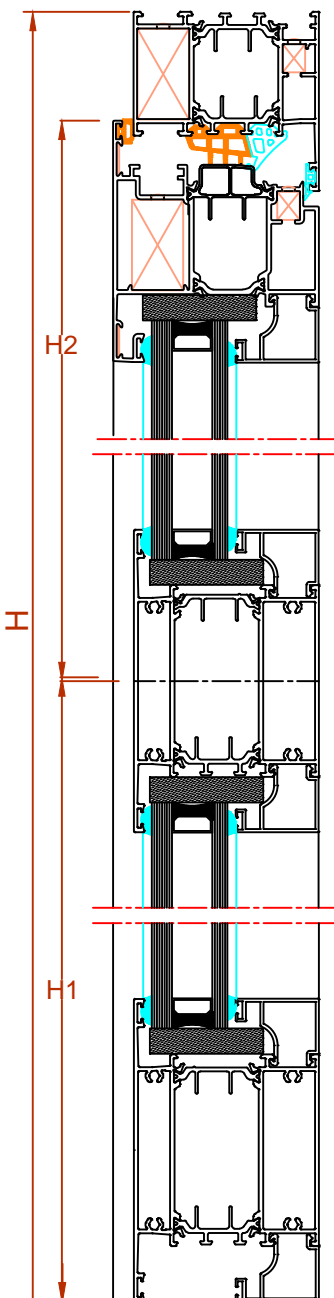

Sección B-B

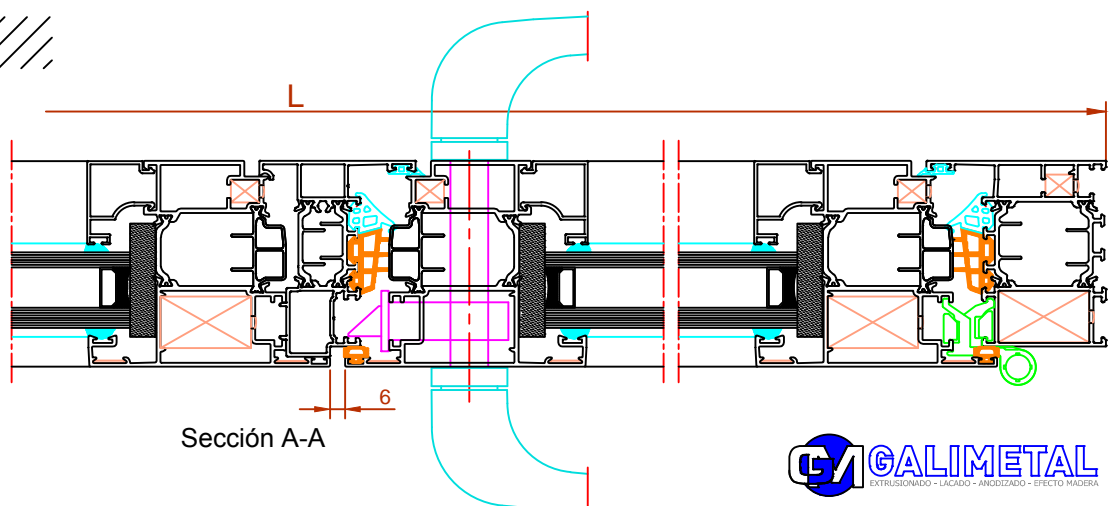

Sección A-A

Fabricación

RT74 CE - H1

1.- CORTE PERFILES

Se cortaran los perfiles de marco y hoja a 45° en ambos extremos, respetando dimensiones y descuentos a aplicar según el modelo a fabricar. Los perfiles inversor y travesaño se cortan a 90°.

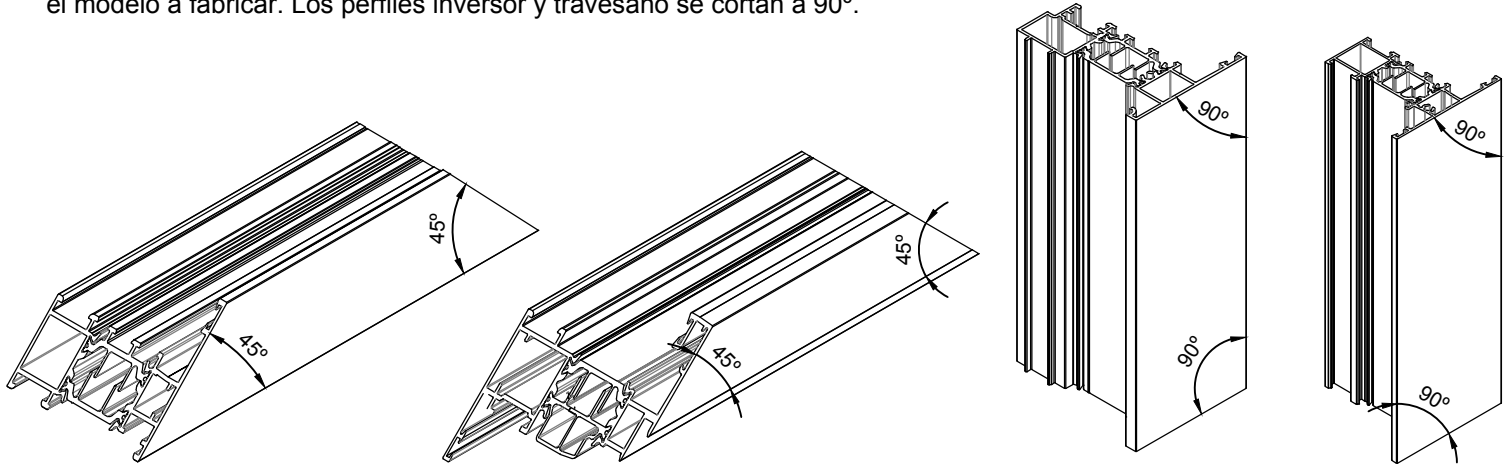

2.- TROQUELADO PERFILES Ver detalle troquel en pag.H7

Marco

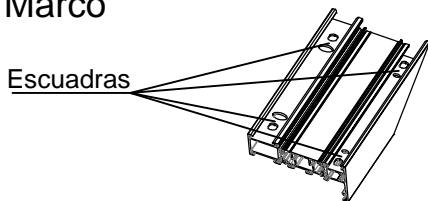

Troquelar las dos cabezas.
El mecanizado varia según se utilice escuadra de extrusión o de inyección

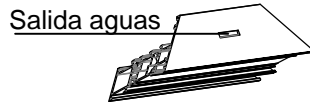

Hacer en el perfil inferior

- Para $L < 600$ mm hacer 1 desagüe situado al centro.
- Para $600 < L < 1300$ mm hacer 2 desagües situados 150 mm de cada extremo.
- Para $L > 1300$ mm hacer 4 desagües según esquema

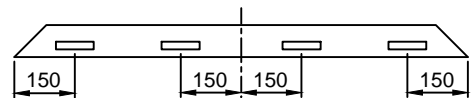

Hoja

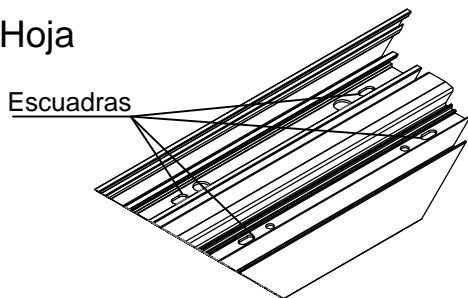

Troquelar las dos cabezas.
El mecanizado varia según se utilice escuadra de extrusión o de inyección

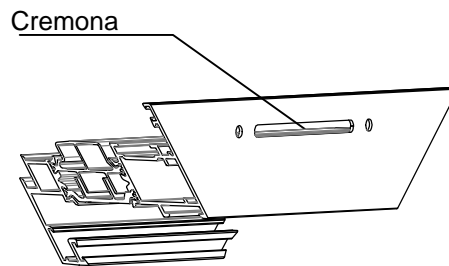

Normalmente al centro de la barra

Paso de herraje

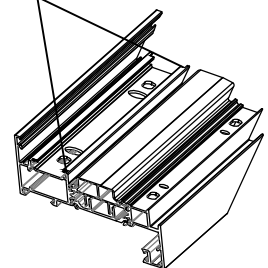

Troquelar las dos cabezas.

Otros

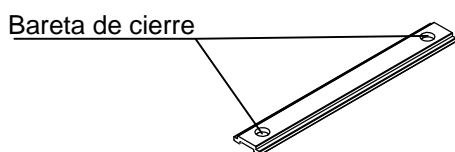

Troquelar las dos cabezas.

Tope unión travesaño

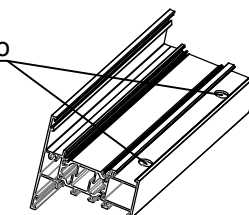

Troquelar las dos cabezas.

Fabricación

RT74 CE - H2

3.- MONTAJE ESCUADRAS

Se aplicará sellante sobre las caras del corte inglete para garantizar la estanqueidad del mismo.
A continuación se montan todas las escuadras necesarias según catalogo y se aprietan las escuadras de bloqueo.

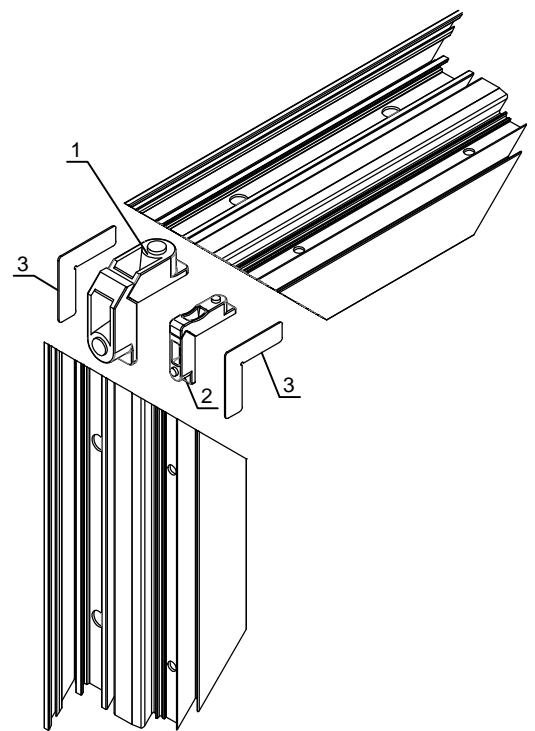
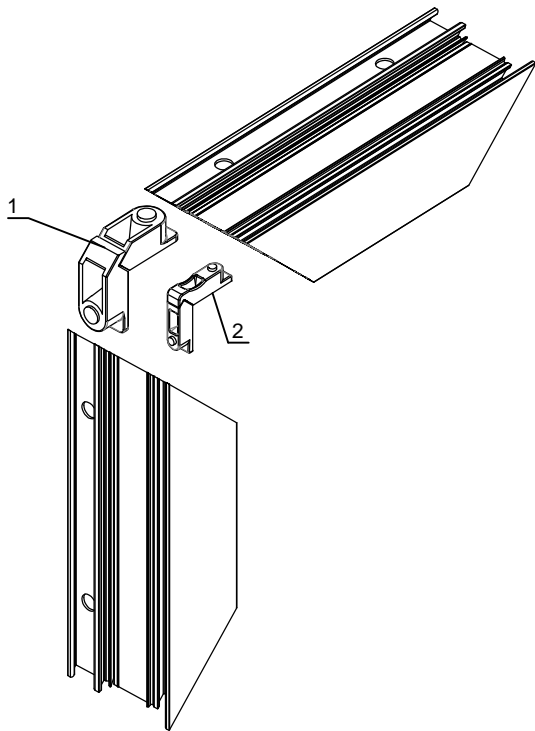

- 1-2: Escuadras bloqueo (extrusión o inyección)
- 3: Escuadras alineamiento

4.- Colocación juntas

Colocar juntas según catalogo: Las centrales de estanqueidad y la acople térmico (en su caso), se colocaran perimetrales continuas en los 4 lados.
La interior no se colocará en el perfil hoja coincidente con el inversor.

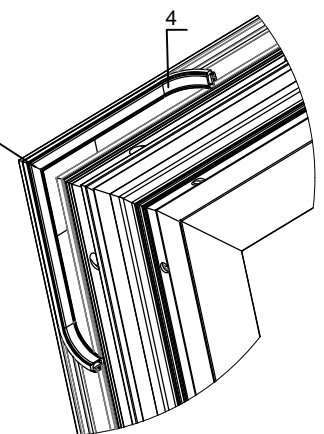
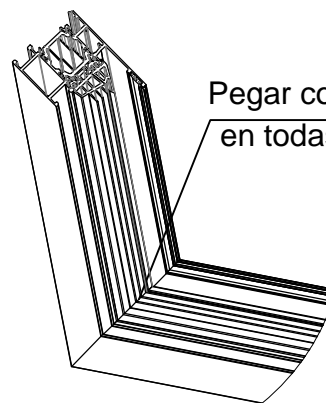
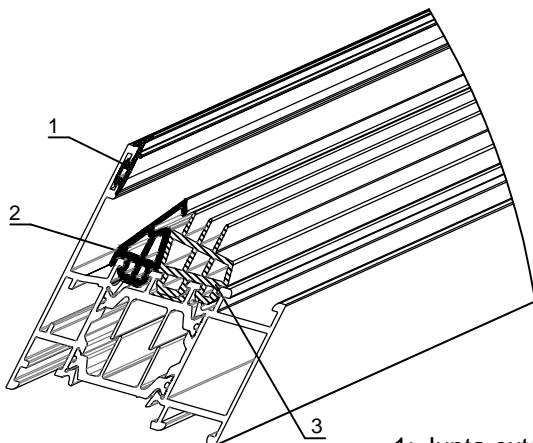

- 1: Junta exterior
- 2: Junta estanqueidad central
- 3: Junta acoplamiento térmico
- 4: Junta interior

4A.- Colocación junta exterior marco

Es necesario realizar cortes en la junta exterior del marco para igualar la presión en la evacuación del agua.

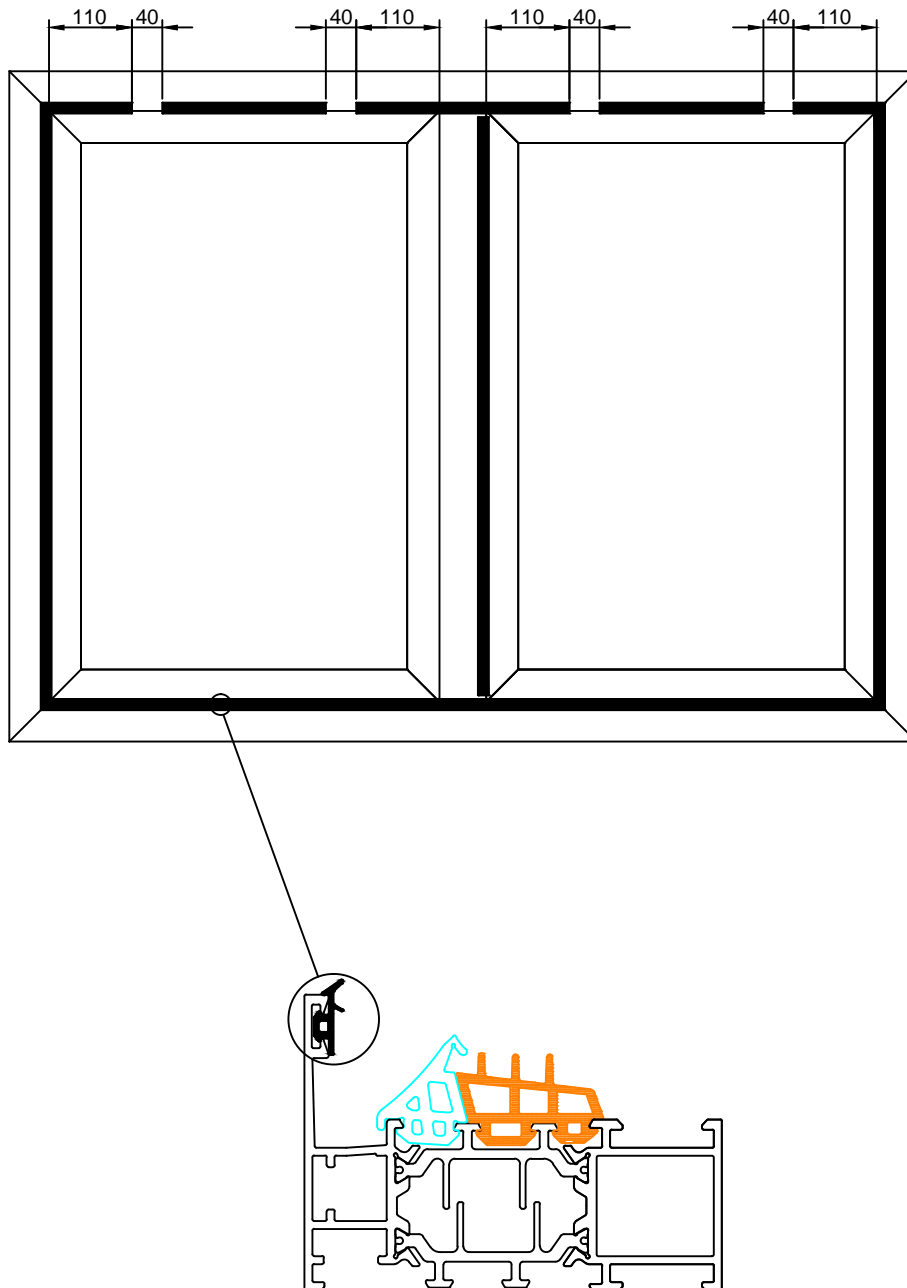

Fabricación

RT74 CE - H4

5.- MONTAJE INVERSOR

- 1.- Aplicar sellante entre perfil inversor y tapa; atornillar tapa con tornillo de 4,2x25 DIN 7971
- 2.- Aplicar sellante en la pestaña exterior del perfil inversor en contacto con el perfil hoja
- 3.- Atornillar perfil inversor a perfil hoja con tornillos de 4,2x32 cada 300-400 mm

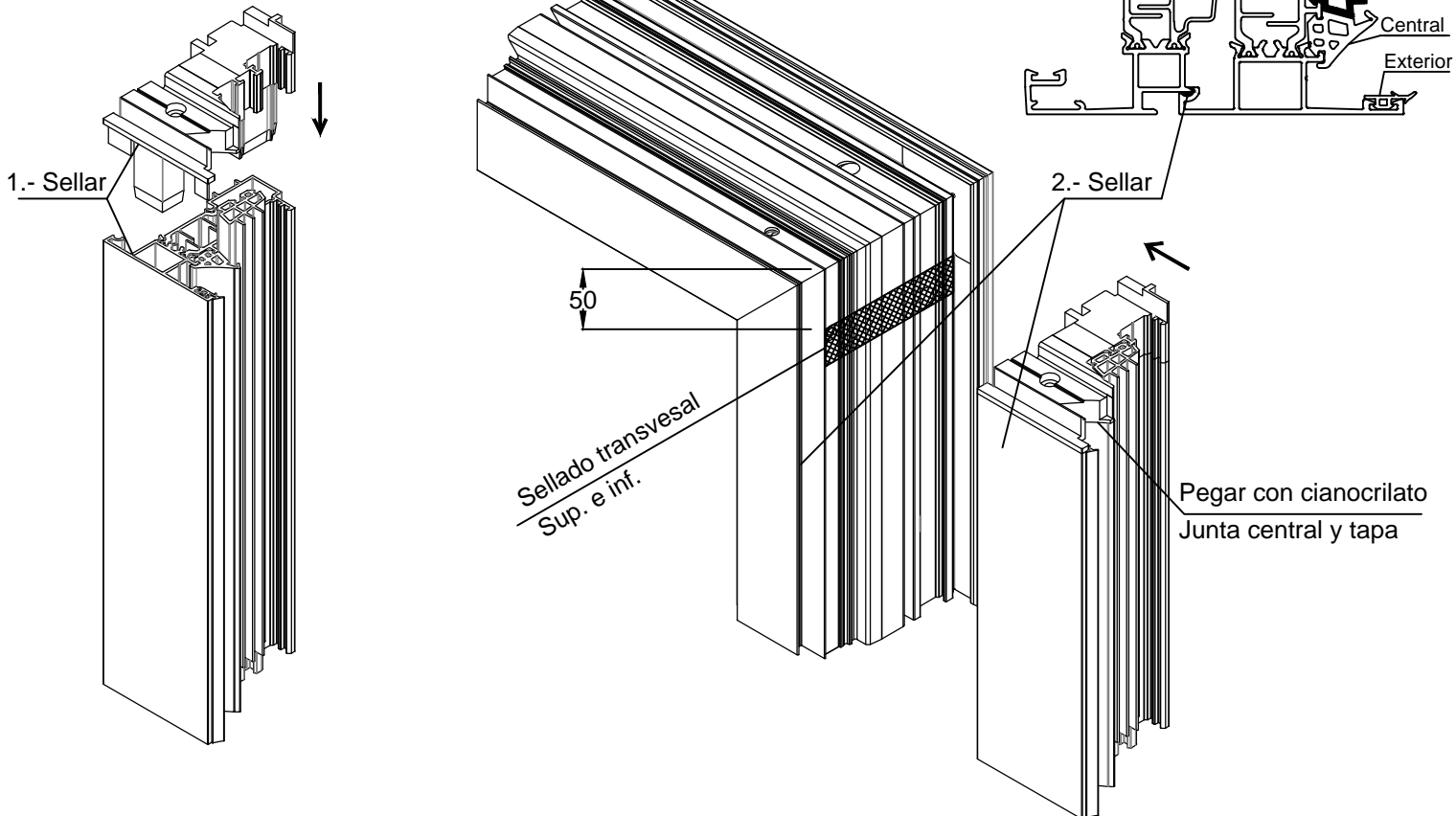

6A.- MONTAJE HOJAS EN MARCO

Ver hojas H4 (oscilobatiente) y H5 (practicable) para determinar compases y cerraderos necesarios según dimensiones
Comprobar huella entre marco y hoja, aproximándola a $6 \text{ mm} \pm 0,5$

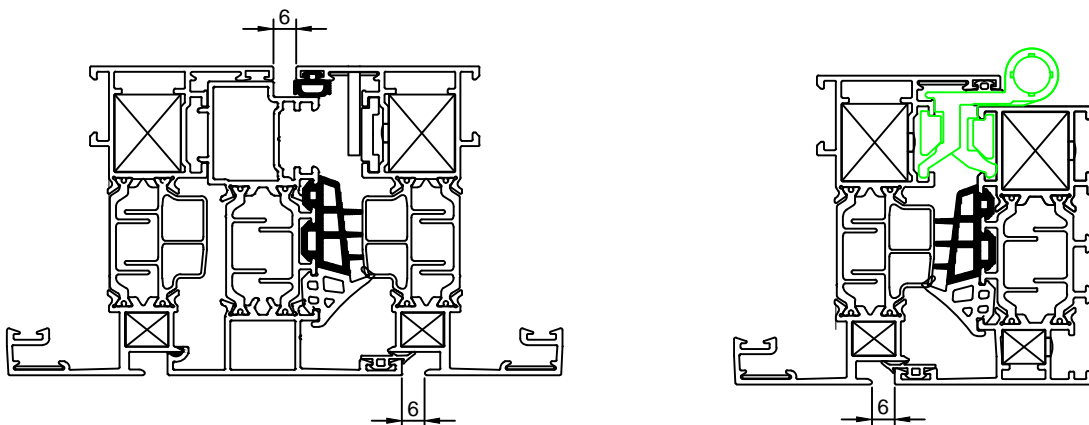

Fabricación

RT74 CE - H5

6B.- HERRAJE OSCIOBATIENTE

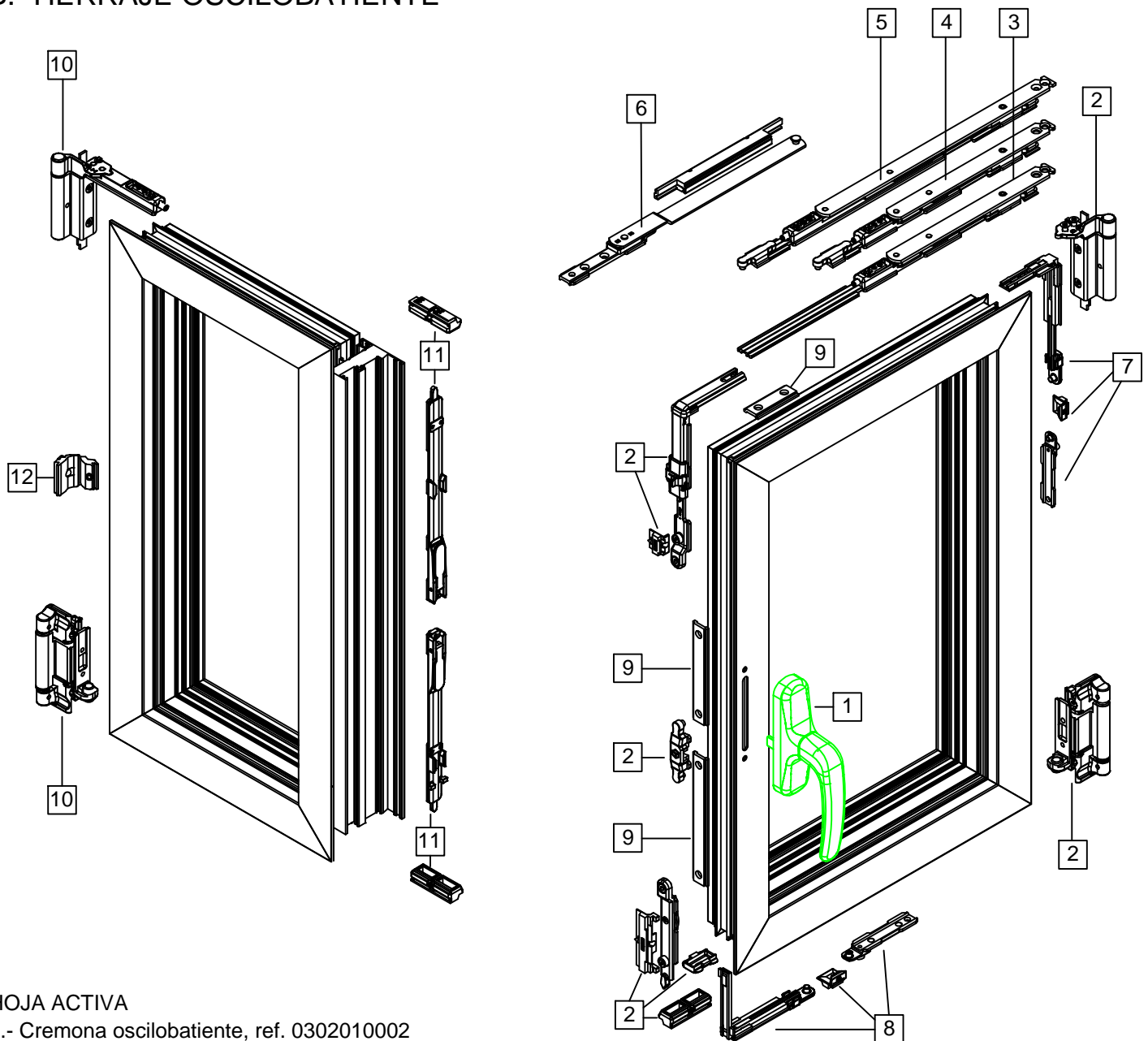

HOJA ACTIVA

- 1.- Cremona oscilobatiente, ref. 0302010002
- 2.- Mecanismo base oscilobatiente, ref. 0202010001
- 3.-Compas pequeño; 370 < ancho hoja < 470 mm. Ref. 0101010001
- 4.-Compas mediano; 471 < ancho hoja < 580 mm. Ref. 0101010002
- 5.-Compas grande; 581 < ancho hoja < 1.700 mm. Ref. 0101010003
- 6.-Compas suplementario; ancho hoja > 1000 mm. Ref. 0101010004
- 7.-Cierre suplementario vertical; 1 Ud. alto hoja > 1200 mm; 2 Uds. alto hoja >1800 mm
- 8.-Cierre suplementario horizontal; ancho hoja > 750 mm (sup. e inf.) .
- 9.-Bareta de cierre; perfil BX-51; ver dimensiones en pag. F16

HOJA PASIVA

- 10.- Conjunto bisagras simetricas hoja pasiva; Ref. 0202010003
- 11.- Juego pasadores hoja pasiva; alto mínimo hoja 625 mm; ref. 0501010001
- 12.- Cierre central oculto; 1 Ud. alto hoja > 1200 mm; 2 Uds. alto hoja > 1800 mm

Fabricación

RT74 CE - H6

6B.- HERRAJE PRACTICABLE al INTERIOR

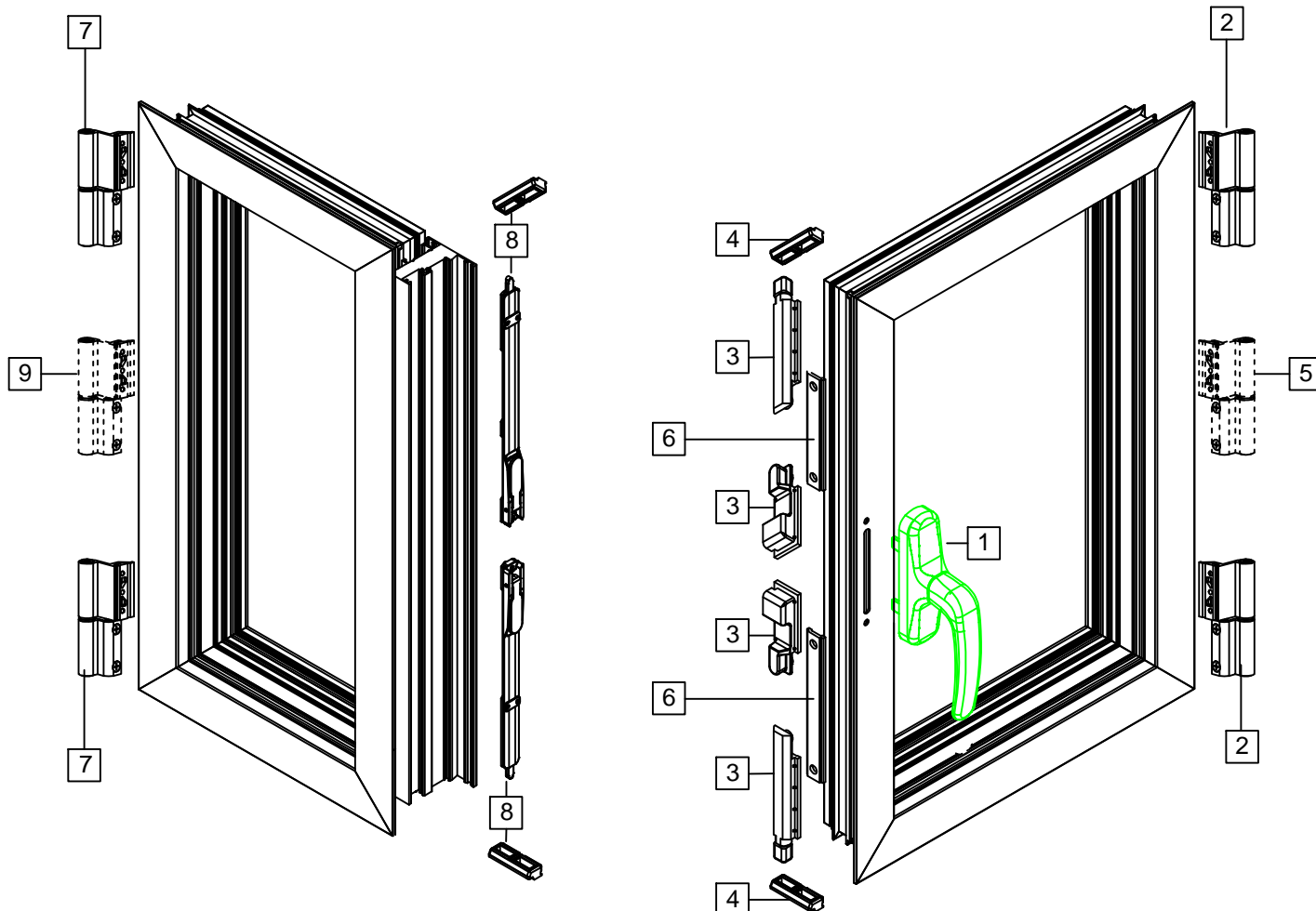

HOJA ACTIVA

- 1.- Cremona practicable. Ref. 0302010001
- 2.- Bisagra practicable der.. Ref. 0602010001
- 3.- Kit cierre practicable apert. int.. Ref. 0407010001
- 4.- Cerradero sup/inf (solo vtas. 1 hoja). Ref. 0407010004
- 5.- Bisagra pract. der. (suplementaria). Ref. 0602010001
1 Ud. alto hoja 1200mm; 2 uds. alto hoja 1800 mm
- 6.- Baretta de cierre; perfil BX-51

HOJA PASIVA

- 7- Bisagra practicable izq.. Ref. 0602010002
- 8.- Juego pasadores zamac; ref. 0501010002
- 9.- Bisagra pract. izq. (suplementaria). Ref. 0602010002
1 Ud. alto hoja 1200mm; 2 uds. alto hoja 1800 mm

Fabricación

RT74 CE - H7

7.- ACRISTALAMIENTO

- Elegir junquillo según espesor vidrio; ver en catalogo técnico pag. D7 en adelante.
- Calzos
 - * La anchura de los calzos será, al menos = espesor total del vidrio
 - * Deben ser de material imputrescible y con dureza apropiada para soportar el peso y que no dañe los cantos del vidrio
- Colocar calzos de acristalamiento según esquemas abajo; la distancia a la esquina del vidrio será mínimo de 50 mm
- A fin de mejorar el aislamiento acústico, el vidrio no debe estar en contacto con los perfiles en ningún punto

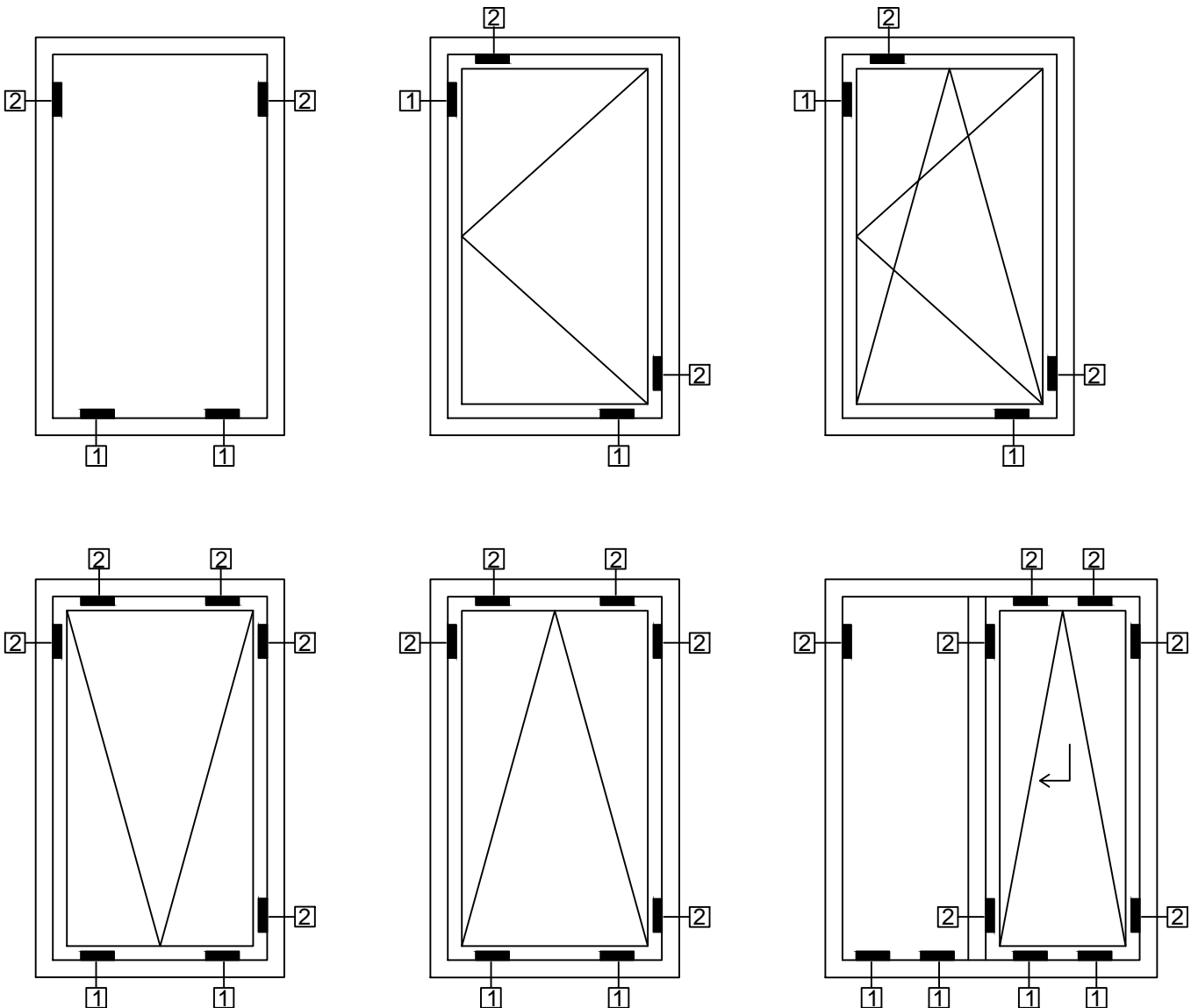

1 = Calzo de apoyo

2 = Calzo de colocación

Fabricación

RT74 CE - H8

8.- TROQUEL

Esquema de posiciones de mecanizado

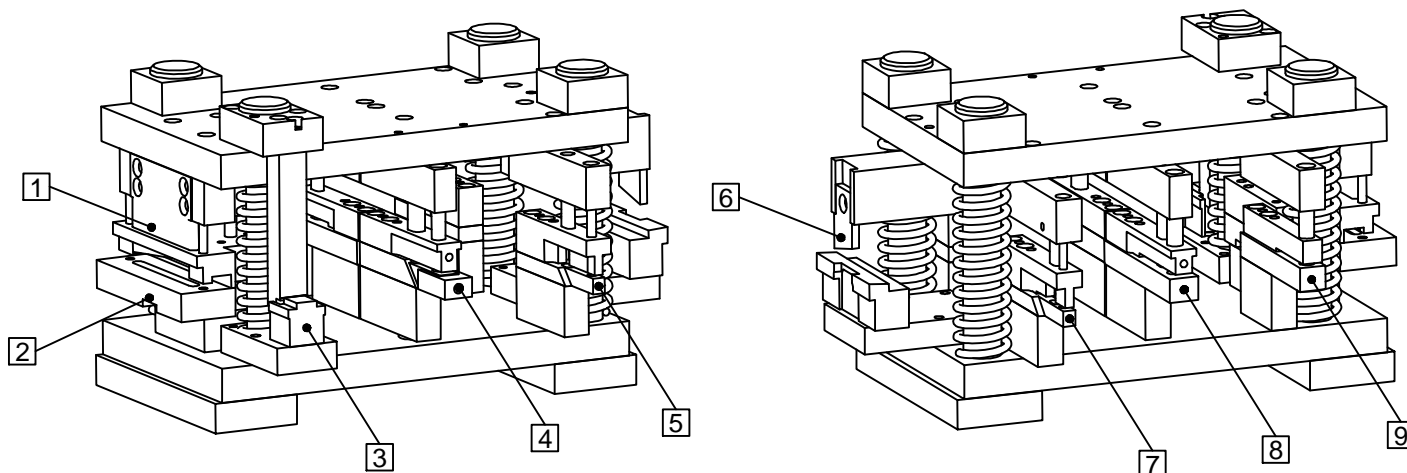

1, 2.- Cremona y baretta

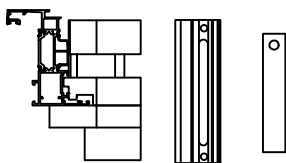

4.- Esc.extrusión principal

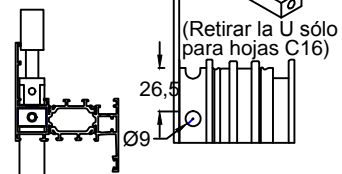

(Hojas puerta acercar perfil hacia la poliamida)

6.- Salida de aguas

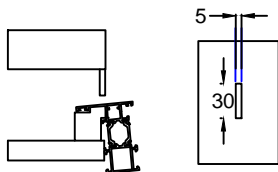

8.- Esc. inyección principal

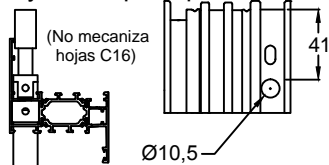

(Hojas puerta acercar perfil hacia la poliamida)

3.- Paso herraje

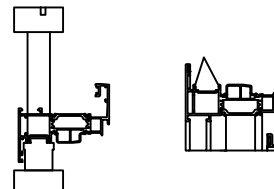

5.- Esc.extrusión secundaria

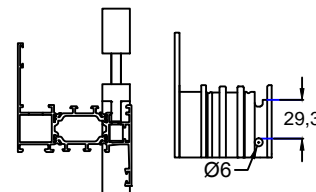

7.- Esc.inyección secundaria

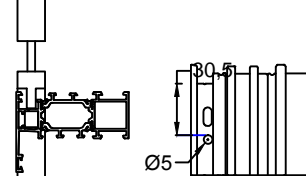

9.- Tope T.

